



Sturdy and reliable joystick for harsh environments and situations. Materials, technical solutions and sizing of critical components are studied to guarantee mechanical resistance and long life, with special attention to design, ergonomics, operation accuracy and sensitivity.

FEATURES

- Structural components are made of die-cast nickel-plated zama to ensure maximum resistance, while parts subject to wear are made of techno-polymer.
- Mechanical life of switches: 5 million operations.
- IP protection degree: Romeo is classified IP00 or IP65, when housed in Romeo-PK or in a specific enclosure.
- Extreme temperature resistance: -25°C to +70°C.

OPTIONS

- Available with up to 6 speeds for each direction.
- Stepped or linear operations with spring return or maintained position.
- Cross or 360° movement.
- 3 different versions: with free movement, with "dead man" safety device (with mechanical interlock with or without NO/NC contact), or with NO pushbutton to be used as electrical interlock.
- 3 different handles, also available with pushbuttons and selector switches.
- Available with potentiometers.

CERTIFICATIONS

- CE marking and EAC certification.

Fill in the "request form" for accurate product configuration.

CERTIFICATIONS

Conformity to Community Directives	2014/35/UE Low Voltage Directive
	2006/42/CE Machinery Directive
Conformity to CE Standards	EN 60204-1 Safety of machinery - Electrical equipment of machines
	EN 60947-1 Low-voltage switchgear and controlgear
	EN 60947-5-1 Low-voltage switchgear and controlgear - Control circuit devices and switching elements - Electromechanical control circuit devices
	EN 61000-6-2 Electromagnetic compatibility (EMC) - Generic standards - Immunity for industrial environments
Markings and homologations	EN 61000-6-3 Electromagnetic compatibility (EMC) - Generic standards - Emission standard for residential, commercial and light-industrial environments
	CE EAC

GENERAL TECHNICAL SPECIFICATIONS

Ambient temperature	Storage -40°C/+70°C
	Operational -25°C/+70°C
IP protection degree	IP 00 (IP 65 max. when housed in Romeo-PK or in a specific enclosure)
Insulation category	Class I
Operating positions	Any position
Mechanical life	0.5x10 ⁶ operations

TECHNICAL SPECIFICATIONS OF THE SWITCHES

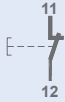
Code	PRVV0804PE
Utilisation category	AC 15
Operating electrical usages	Inductive load 48 Vac/1 A 125 Vac/1 A 250 Vac/0.5 A 30 Vdc/1 A
	Resistive load 48 Vac/2 A 125 Vac/3 A 250 Vac/2 A 30 Vdc/3 A
Rated thermal current	8 A
Rated insulation voltage	1000 Vac
Mechanical life	5x10 ⁶ operations
Connections	Screw-type terminals
Wires	0.2 mm ² - 2.5 mm ²
Tightening torque	0.5 Nm - 0.6 Nm
Microswitch type	Single break
Contacts	1NC
Scheme	
Markings and homologations	CE CB CUL US VDE

TECHNICAL SPECIFICATIONS OF THE BUTTONS

Code	PRVV5019PE	PRVV5020PE	PRVV5080PE
Color	Green	Black	Green
Contact rated current	Resistive load 32 Vac/400 mA Resistive load 50 Vdc/100 mA Resistive load 125 Vac/125 mA		Resistive load 28 Vdc/5 A Resistive load 125 Vac/125 mA
Contact resistance	50 mΩ		-
Mechanical life	1x10 ⁶ operations		1x10 ⁶ operations
Contacts	1NO		1NO
Markings and homologations	CE		CE

TECHNICAL SPECIFICATIONS OF THE POTENTIOMETERS

Code	PRVV9020PE	PRVV9025PE	PRVV9035PE
Ohmic value	4,7 kΩ	10 kΩ	2,2 kΩ
Independent linearity (over AEA -3°)	±0.25%		
Life time	3x10 ⁶ movements		
Operational ambient temperature	-55°C/+125°C		
Mechanical angle	360° continuous		
Actual Electrical Angle (AEA)	355°±5°		
Ohmic value tolerance	±5%		
Temperature drift	< 50 PPM/°C		
Dissipation	4 W		

OVERALL DIMENSIONS (mm)

With knob

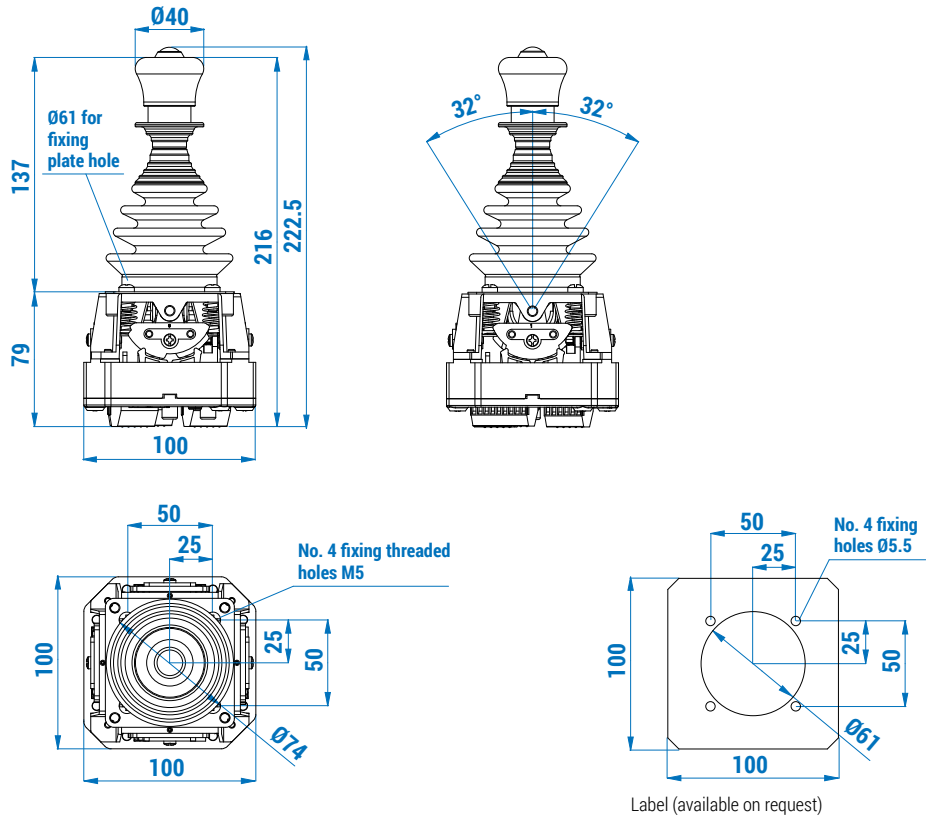

With potentiometer

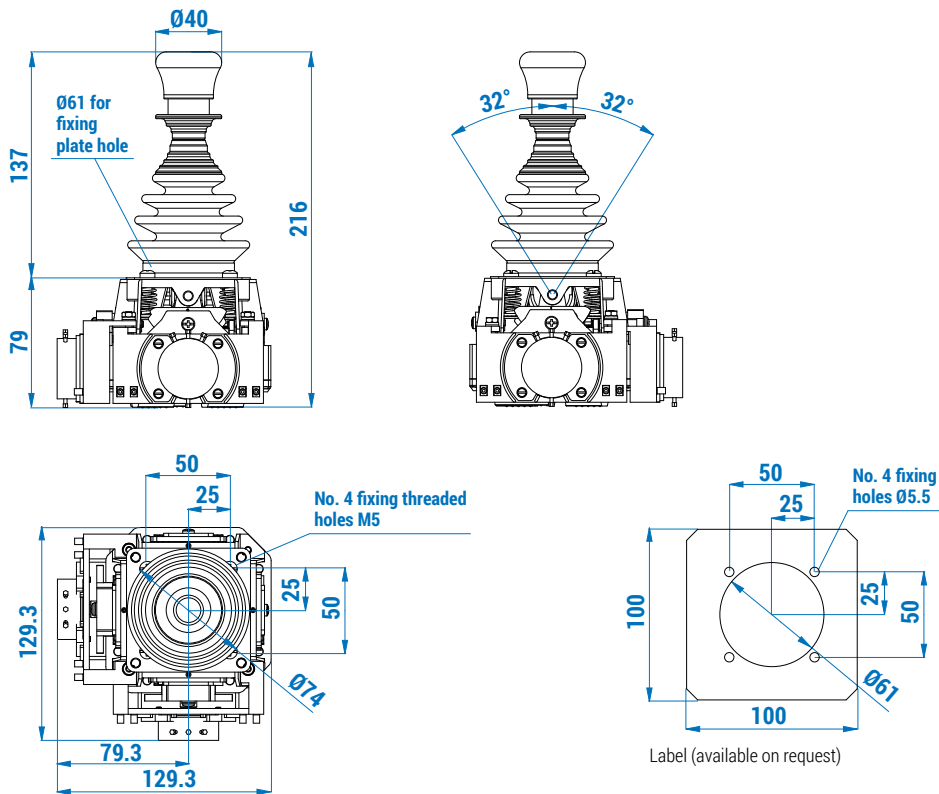

With handle

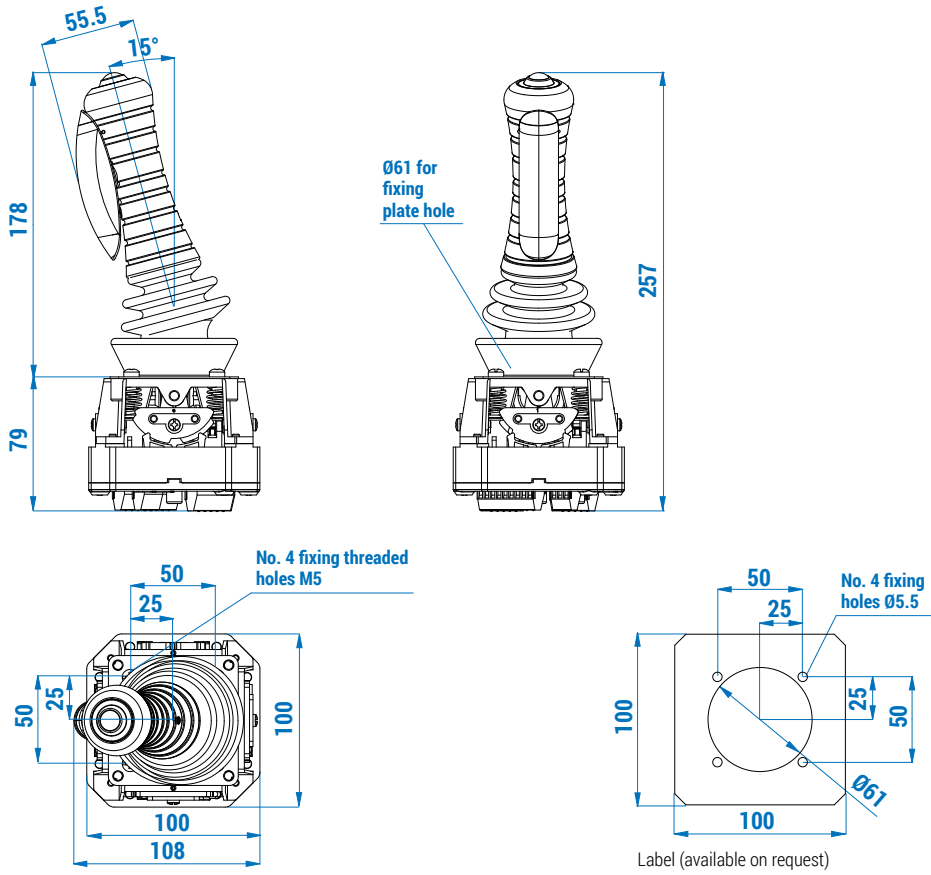

With ergonomic handle

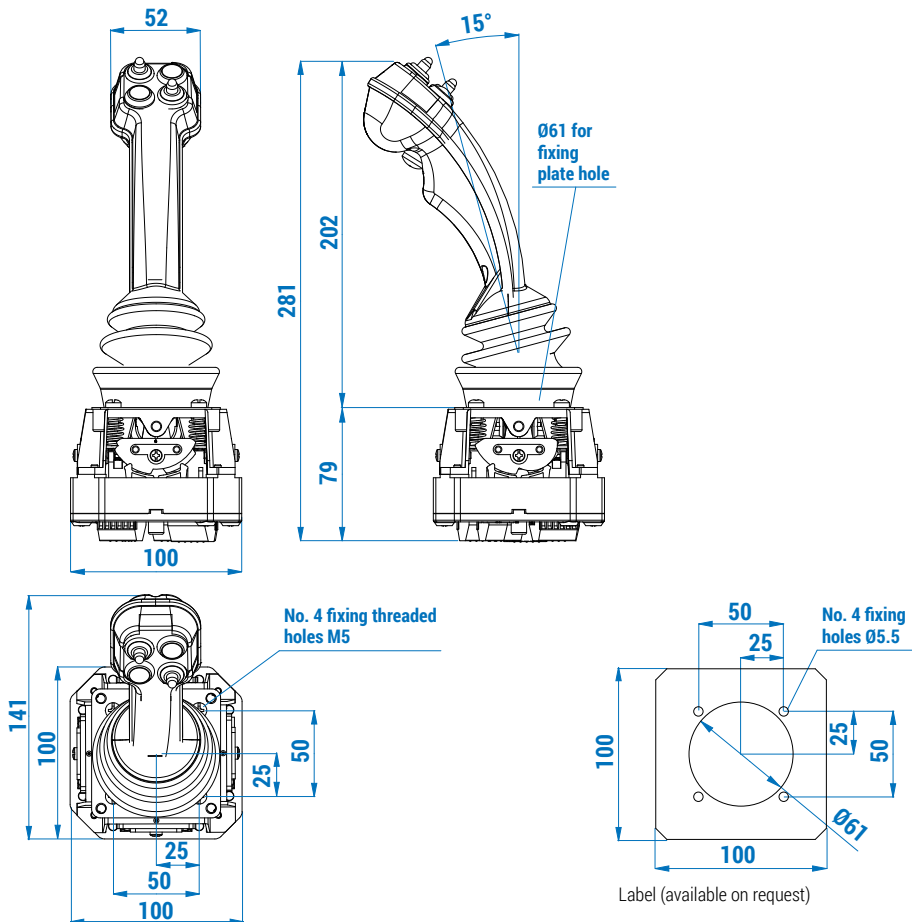



STANDARD JOYSTICKS



Romeo standard joysticks feature spring return stepped movement and they are equipped with 1NC switches

PRVV0804PE  and fixed terminal board.

3

Grip type	Positions	Direction of movement		Code	
		360°	Cross	Free movement	Mechanical interlock + NC/NO contact
	1-0		X	PF580C010001	PF580C010002
	1-1	X		PF580L011001	PF580L011002
	2-0		X	PF580C020001	PF580C020002
	2-2	X		PF580L022001	PF580L022002
	3-0		X	PF580C030001	PF580C030002
	3-1	X		PF580L031001	PF580L031002
	3-2	X		PF580L032001	PF580L032002
	3-3	X		PF580L033001	PF580L033002
	4-0		X	PF580C040001	PF580C040002
	4-1	X		PF580L041001	PF580L041002
	4-2	X		PF580L042001	PF580L042002
	4-3	X		PF580L043001	PF580L043002
	4-4	X		PF580L044001	PF580L044002
	5-0		X	PF580C050001	PF580C050002
	5-1	X		PF580L051001	PF580L051002
	5-2	X		PF580L052001	PF580L052002
	5-3	X		PF580L053001	PF580L053002
	5-4	X		PF580L054001	PF580L054002
	5-5	X		PF580L055001	PF580L055002
	6-1	X		PF580L061001	PF580L061002
	6-2	X		PF580L062001	PF580L062002
	6-3	X		PF580L063001	PF580L063002
	6-4	X		PF580L064001	PF580L064002
	6-5	X		PF580L065001	PF580L065002
	6-6	X		PF580L066001	PF580L066002

Grip type	Positions	Direction of movement		Code
		360°	Cross	1NO button
	4-4		X	PF580C044016

Grip type	Positions	Direction of movement		Code		
		360°	Cross	Free movement	1NO button (for use as electrical interlock)	
Handle 	1-0		X	PF580C010006	PF580C010003	
	1-1	X		PF580L011006	PF580L011003	
	2-0		X	PF580C020008	PF580C020003	
	2-2	X		PF580L022008	PF580L022003	
	3-0		X	PF580C030006	PF580C030003	
	3-1	X		PF580L031007	PF580L031003	
	3-2	X		PF580L032006	PF580L032003	
	3-3	X		PF580L033006	PF580L033003	
	4-0		X	PF580C040008	PF580C040003	
	4-1	X		PF580L041007	PF580L041003	
	4-2	X		PF580L042006	PF580L042003	
	4-3	X		PF580L043006	PF580L043003	
	4-4	X		PF580L044007	PF580L044003	
	5-0		X	PF580C050006	PF580C050003	
	5-1	X		PF580L051006	PF580L051003	
	5-2	X		PF580L052006	PF580L052003	
	5-3	X		PF580L053006	PF580L053003	
	5-4	X		PF580L054006	PF580L054003	
	5-5	X		PF580L055006	PF580L055003	
	6-1	X		PF580L061006	PF580L061003	
	6-2	X		PF580L062006	PF580L062003	
	6-3	X		PF580L063006	PF580L063003	
	6-4	X		PF580L064006	PF580L064003	
	6-5	X		PF580L065006	PF580L065003	
	6-6	X		PF580L066006	PF580L066003	
	Ergonomic handle 	1-0		X	PF580C010004	PF580C010005
		1-1	X		PF580L011004	PF580L011005
		2-0		X	PF580C020004	PF580C020005
		2-2	X		PF580L022004	PF580L022005
		3-0		X	PF580C030004	PF580C030005
3-1		X		PF580L031004	PF580L031005	
3-2		X		PF580L032004	PF580L032005	
3-3		X		PF580L033004	PF580L033005	
4-0			X	PF580C040004	PF580C040005	
4-1		X		PF580L041004	PF580L041005	
4-2		X		PF580L042004	PF580L042005	
4-3		X		PF580L043004	PF580L043005	
4-4		X		PF580L044004	PF580L044005	
5-0			X	PF580C050004	PF580C050005	
5-1		X		PF580L051004	PF580L051005	
5-2		X		PF580L052004	PF580L052005	
5-3		X		PF580L053004	PF580L053005	
5-4		X		PF580L054004	PF580L054005	
5-5		X		PF580L055004	PF580L055005	
6-1		X		PF580L061004	PF580L061005	
6-2		X		PF580L062004	PF580L062005	
6-3		X		PF580L063004	PF580L063005	
6-4		X		PF580L064004	PF580L064005	
6-5		X		PF580L065004	PF580L065005	
6-6		X		PF580L066004	PF580L066005	

ASSEMBLY DRAWING

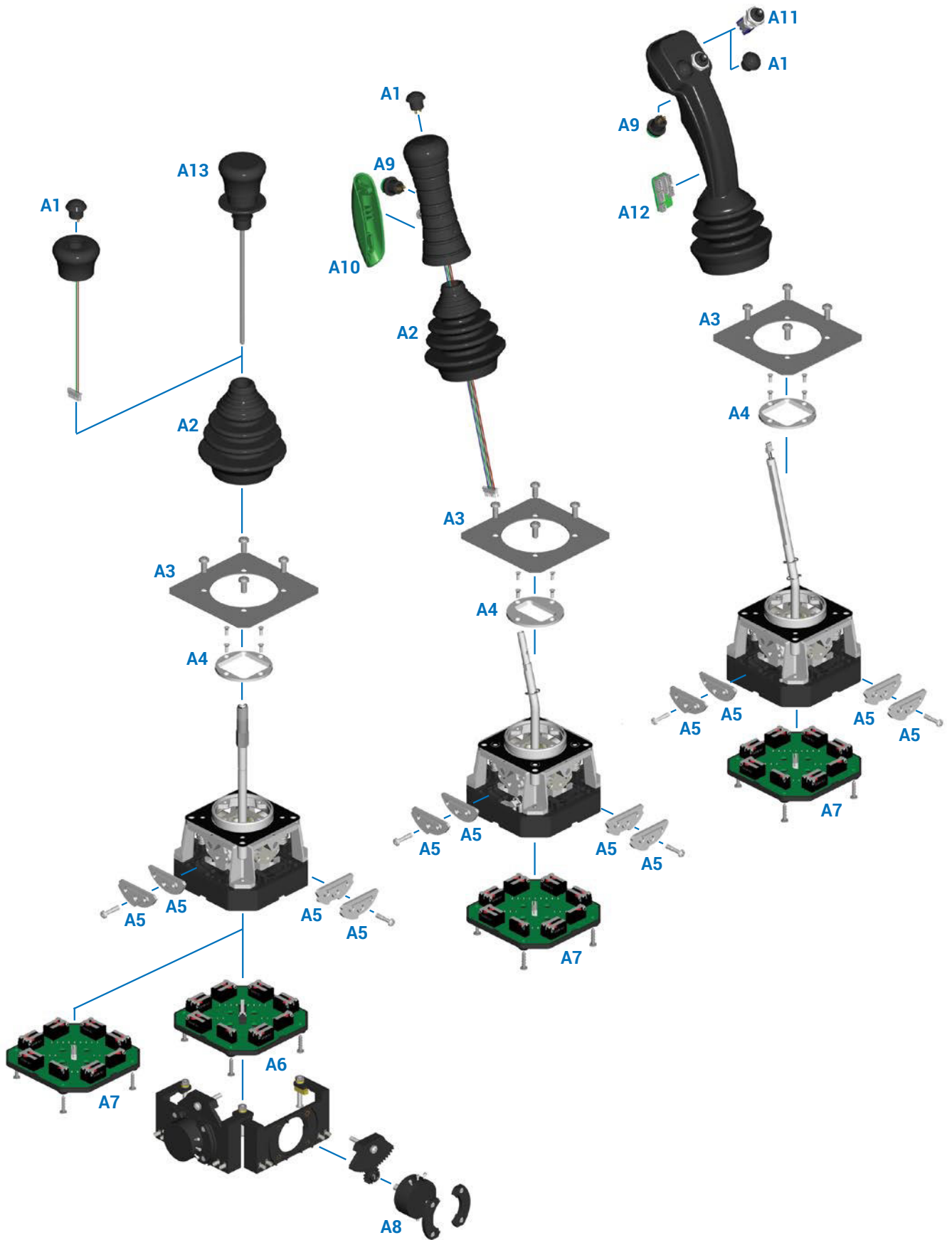

3





Refer to the following tables for descriptions of components: "Buttons", "Switch boards", "Potentiometers", "Selector switches", "Lever guides", "Cams" and "Accessories".

COMPONENTS

Buttons

Ref.	Drawing	Description	Code
A1		Green 1NO button	PRVV5019PE
		Black 1NO button	PRVV5020PE
A9		Green 1NO button	PRVV5080PE
A10		Trigger button	PRSL7595PI

Switch boards

Ref.	Drawing	Description	Code
A6		6 speed board, 14 switches + electrical interlock	93620
		3 speed board, 8 switches + electrical interlock	93621
A7		6 speed board, 14 switches	93623
A12		Board for ergonomic handle	93624

Potentiometers

Ref.	Drawing	Description	Code
A8		Potentiometer 2.2 kΩ	PRVV9035PE
		Potentiometer 4.7 kΩ	PRVV9020PE
		Potentiometer 10 kΩ	PRVV9025PE

Selector switches

Ref.	Drawing	Description	Code
A11		2 maintained position selector switch ON-ON wired	PRVV0830PE
		3 maintained position selector switch ON-OFF-ON wired	PRVV0831PE
		2 position spring return selector switch ON-MOM wire	PRVV0832PE
		3 position selector switch MOM-OFF-MOM wired	PRVV0833PE
		3 position selector switch ON-OFF-MOM wired	PRVV0834PE
		2 maintained position selector switch ON-OFF wired	PRVV0840PE
		2 position selector switch MOM-OFF wired	PRVV0842PE



Lever guides

Ref.	Drawing	Description	Code
A4		Cross lever guide	PRGC6666PE
		Lever guide 1/0	PRGL1100PE
		Lever guide 1/1	PRGL1111PE
		Lever guide 2/0-4/0	PRGL4400PE
		Lever guide 4/1	PRGL4411PE
		Lever guide 4/2-2/1	PRGL4422PE
		Lever guide 4/3	PRGL4433PE
		Lever guide 4/4-2/2	PRGL4444PE
		Lever guide 5/0	PRGL5500PE
		Lever guide 5/1	PRGL5511PE
		Lever guide 5/2	PRGL5522PE
		Lever guide 5/3	PRGL5533PE
		Lever guide 5/4	PRGL5544PE
		Lever guide 5/5	PRGL5555PE
		Lever guide 6/0-3/0	PRGL6600PE
		Lever guide 6/1	PRGL6611PE
		Lever guide 6/2-3/1	PRGL6622PE
		Lever guide 6/3	PRGL6633PE
		Lever guide 6/4-3/2	PRGL6644PE
		Lever guide 6/5	PRGL6655PE
Lever guide 3/3-6/6	PRGL6666PE		

Cams

Ref.	Drawing	Description	Code
A5		Cam 1 st position - 6/3 speeds	CKR60006
		Cam 2 nd -3 rd position - 6 speeds	CKR60008
		Cam 6 th position - 6 speeds	CKR60009
		Cam 4 th -5 th position - 6 speeds	CKR60007

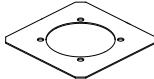
Accessories

Ref.	Drawing	Description	Code
A2		Bellows	PRGU6050PE
A3		Blank label	PRTA0150PE
		Lifting-Transpose label	PRTA0151PE
		Trolley-Rotation label	PRTA0152PE
A13		Knob with rod	PRSL4558PI

ROMEO - REQUEST FORM FOR NON STANDARD JOYSTICK

Grip type

Knob (IP 65 assembled in specific enclosure)

Function

Free movement

Mechanical interlock + NC/NO contact

P1 1NO button

Colour of button

black

green

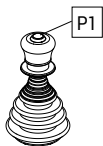

Handle (IP 44 assembled in specific enclosure)

Function

Free movement

P2 1NO button

P3 1NO button

Colour of button

black

green

P2 1NO button + P3 1NO button

Colour of button

black

green

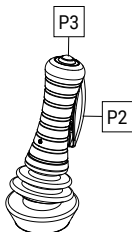

Ergonomic handle (IP43 assembled in specific enclosure)



1NO buttons can be used as electrical interlock.

Actuators for ergonomic handle

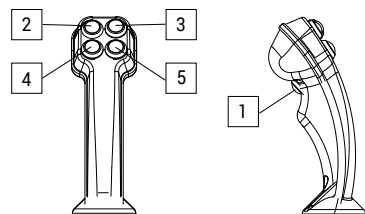

Actuator type* and label letterings

Pos.

1 Yes No PRVV5080PE Green button 1NO contact + 1 common**

Type Lettering

2 _____

3 _____

4 _____

5 _____

Movement

Stepped - spring return

Stepped - maintained positions

Linear - spring return

Lever guide

Standard lever guide

Customized lever guide

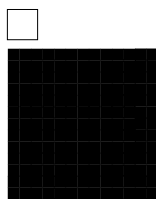

6 steps directions A-B
6 steps directions C-D
360° movement

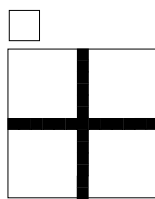

6 steps directions A-B
6 steps directions C-D
Cross movement

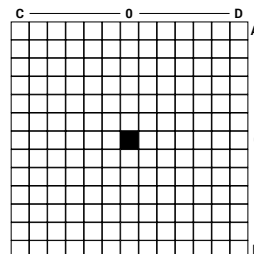

Joystick label

Blank label

Lifting-Traversal symbols

Trolley-Rotation symbols

Customized label

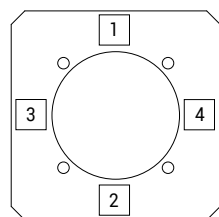

Pos. Letterings

1 _____

2 _____

3 _____

4 _____

Actuators for positions 2-3-4-5

A PRVV5019PE Green button 1NO contact + 1 common

B PRVV5020PE Black button 1NO contact + 1 common

C PRVV0840PE 2 position selector ON-OFF 1 contact + 1 common

D PRVV0842PE 2 position selector MOM-OFF 1 contact + 1 common

E PRVV0830PE 2 maintained position selector ON-ON 2 contacts + 1 common

F PRVV0831PE 3 maintained position selector ON-OFF-ON 2 contacts + 1 common

G PRVV0832PE 2 position spring return selector ON-MOM 2 contacts + 1 common

H PRVV0833PE 3 position selector MOM-OFF-MOM 2 contacts + 1 common

I PRVV0834PE 3 position selector ON-OFF-MOM 2 contacts + 1 common

* Maximum 5 contacts + 1 common available.
Ex.: 1NO contact in position 1 + 4 buttons A type.
1NO contact in position 1 + 4 selectors C type.
1NO contact in position 1 + 2 selectors G type.

** In case of use of the electrical interlock function, connect it to actuator 1.

Joystick with potentiometers

Potentiometer

- 1 PRVV9035PE 2.2 kΩ
- 2 PRVV9020PE 4.7 kΩ
- 3 PRVV9025PE 10 kΩ
- 4 Preset only

Instructions

When necessary, write the number corresponding to the potentiometer or to the preset required. Fill in the contact scheme blackening the boxes corresponding to the positions where the cams close the contacts (each bar of 13 boxes correspond to a switch; the central box corresponds to the zero position of the joystick). In the example, the contact is closed in positions 1-2-3 to the left and 3-4 to the right.

6	5	4	3	2	1	0	1	2	3	4	5	6

