

- Measuring length 50 - 5000 mm
- 16 bit resolution
- 0 - 10V, 0 - 20 mA, 4 - 20 mA output
- Speed information can be provided optionally.

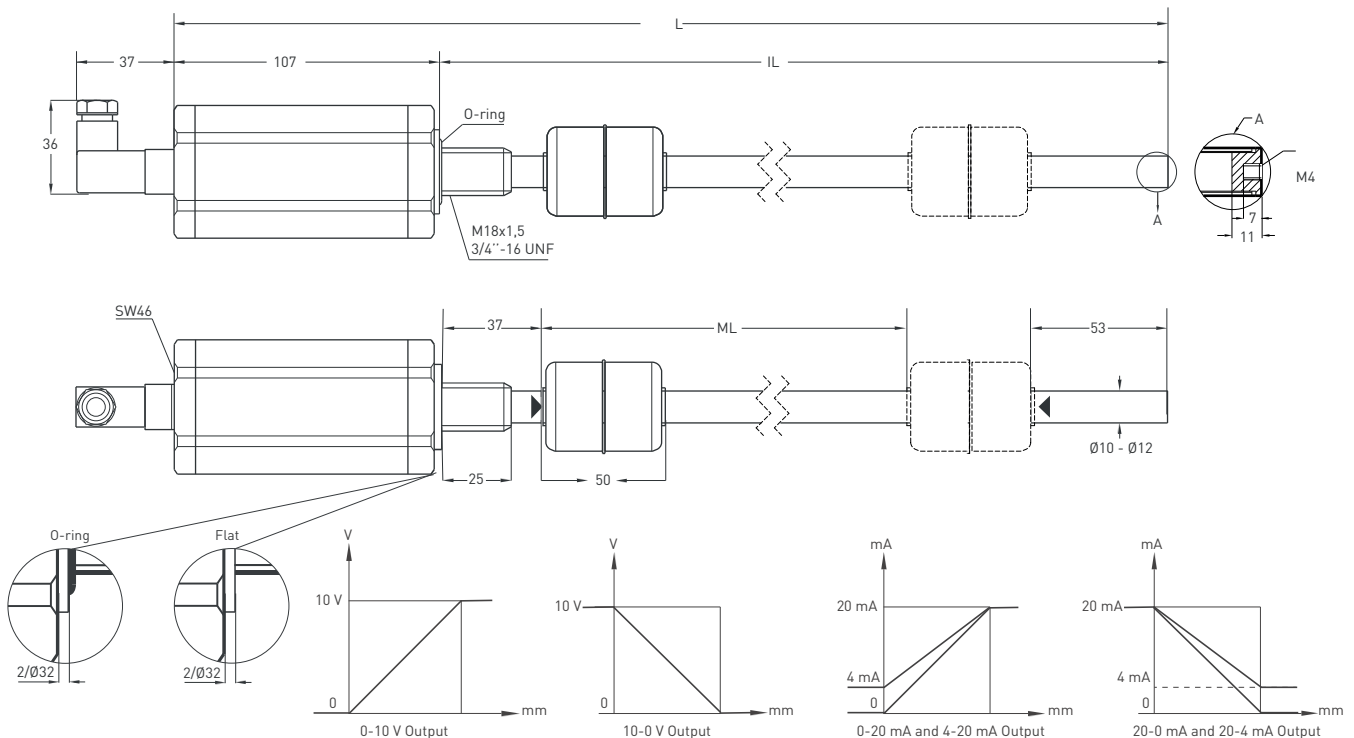

Technical Specifications	
Measurement stroke	50 to 5000mm
Resolution	16 bit DAC output
Repeatability	100 µm
Output	0-10V, 10-0V, 0-20 mA, 20-0 mA, 4-20 mA, 20-4 mA (Speed information can be provided optionally.)
Power supply	24 VDC ±10%
Displacement speed	max. < 5 m/s
Sampling rate	Up to 2 kHz (depending on stroke length)
Max. consumption	50 mA - 90 mA (depending on stroke length)
Max. output noise	< 5mVpp
Linearity	50-100 mm < %1, 100-300 mm < %0.2, 300-500 mm < %0.1, 500-5000 mm > %0.05
Vibration	EN 60068-2-6 , 5-200 Hz 200 m/s ² (20g) , 2h 30min each axis {x,y,z}
Shock	EN 60068-2-2:2007 500 m/s ² (50g) , 11ms. {x,y,z axis}
Update time	1 ms (1000 mm up to), 2 ms (2000 mm up to), 3 ms (5000 mm up to)
Reverse polarity protection	Up to -30 VDC
Overvoltage protection	Up to +30 VDC
Pressure rating	< 500 bar
Mounting	M18 x 1.5 or 3/4"-16 UNF
Case material	Profile : Anodized aluminium, Tube : Stainless steel, Caps : Stainless steel
Protection level	IP 65
Operating temperature	-10°C ... +70°C
Storage temperature	-30°C ... +90°C

Mechanical Specifications



MSTL (mm)	50	100	150	200	250	300	350	400	450	500	550	600	650	700	750	800	850	900	1000	1100	1200	1300	1400	1500	1750	2000	2250	2500	3000	4000	5000
ML (Measuring Length)	50	100	150	200	250	300	350	400	450	500	550	600	650	700	750	800	850	900	1000	1100	1200	1300	1400	1500	1750	2000	2250	2500	3000	4000	5000
IL (Installation Length)	190	240	290	340	390	440	490	540	590	640	690	740	790	840	890	940	990	1040	1140	1240	1340	1440	1540	1640	1890	2140	2390	2728	3228	4228	5228
(Total Length)	297	347	397	447	497	547	597	647	697	747	797	847	897	947	997	1047	1097	1147	1247	1347	1447	1547	1647	1747	1997	2340	2590	2840	3360	4360	5360
Dead Zone Calculation	37/53 mm																														

Round Connector

5 pin Connector Configuration

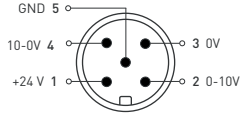

CN5 M12 (A) / M16 (B)
5 pin

6 pin Connector Configuration

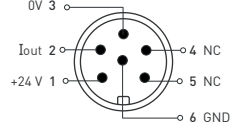

CN6 M12 (A) / M16 (B)
6 pin

8 pin Connector Configuration

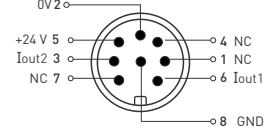

CN8 M12 (A) / M16 (B)
8 pin

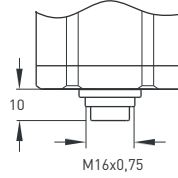
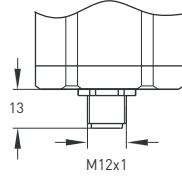

Hydraulic Type Connector

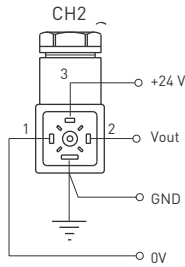

0-10V or 10-0V Output

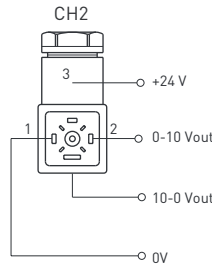

0-10V and 10-0V Output

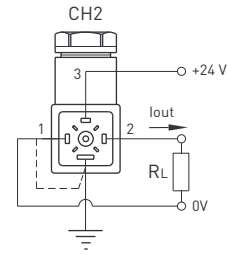

0-20mA or 4-20mA Output

Cable

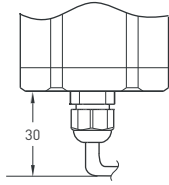

Voltage Output

+V : Brown
0V : Blue
0V Sense : Black
Output 1 : White (0-10V)
Output 2 : Orange (10-0V)
Earth : Shield

Current Output

+V : Brown
0V : Blue
0V Sense : Black
Output 1 : White (Iout 1)
Output 2 : Orange (Iout 2)
Earth : Shield

Cable Length

1M : 1 meter (standard)
(Different cable length optional.)

Cursor

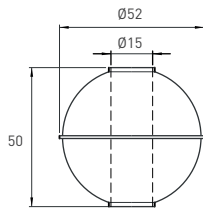

F01T
Floater
Ø 50x50 mm
Stainless steel
(MST/MSP/MSTL)

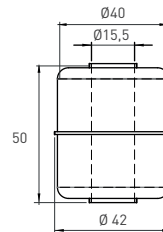

F02T
Floater
Ø 50x40 mm
Stainless steel
(MST/MSP/MSTL)

Ordering Procedure

Model	Measuring range	Rod & Thread	Sealing surface	Resolution	Cursor	Output1	Output2 (optional)	Connector / Cable	Dead zone
MSTL	900	E12	S	A	F01T	V10	Sxxx	CH2	37/53
MSTL	50 - 5000 mm	E10 : Ø10, M18x1,5 E12 : Ø12, M18x1,5 U10 : Ø10, 3/4"-16 UNF U12 : Ø12, 3/4"-16 UNF EO10 : Ø10, M24x1,5 EO12 : Ø12, M24x1,5 EA10 : Ø10, M24x1,5 EA12 : Ø12, M24x1,5 EB10 : Ø10, M30x2 EB12 : Ø12, M30x2	S: O-ring F: Flat	A: 16 bit B: 15 bit C: 14 bit D: 13 bit E: 12 bit	F01T Ø50x50mm F02T Ø50x40mm F03T Ø50x35mm	V10 : 0-10V I40 : 4-20mA 2V10 : 0-10V/0-10V 2I40 : 4-20mA/4-20mA V01 : 10-0V I04 : 20-4mA 2V01 : 10-0V/10-0V 2I04 : 20-4mA/20-4mA V11 : 0-10V/10-0V I41 : 4-20mA/20-4mA V50 : 0-5V I20 : 0-20mA 2V50 : 0-5V/0-5V 2I20 : 0-20mA/0-20mA V05 : 5-0V I02 : 20-0mA 2V05 : 5-0V/5-0V 2I02 : 20-0mA/20-0mA V51 : 0-5V/5-0V I21 : 0-20mA/20-0mA	Sxxx S : Speed xxx : max. speed (mm/s)	CH2: Hydraulic type (standard) CN5A: M12 37/53 CN5B: M16 47/53 CN6A: M12 57/53 CN6B: M16 67/53 CN8A: M12 77/53 CN8B: M16 30/60 51/63 1M:1 meter(standard) Different cable lengths available (optional)	≤ 2000 mm 30/53 > 2000-3000 mm 130/53 > 3000-5000 mm 150/53

* T-coded sensors are used with T-coded cursors.