

FF 12

DIAPHRAGM LIQUID PUMP



FF 12 DC-M



FF 12 DCB



FF 12 DCB-4

ADVANTAGES

- Great adjustability of flow rate
- Mounting plate with click-on mechanism
- Self-priming and dry-run proof
- Clean and gentle transfer of sensitive media
- Resistant materials to transfer aggressive media
- Long lifetime, no maintenance

POSSIBLE AREAS OF USE

- Medical technology
- Laboratory technology
- Inkjet printing
- Fuel cells
- Semiconductor industry
- And many more

Please visit our website
www.knf.com
 to get more information.

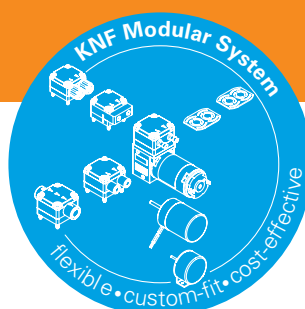

PERFORMANCE DATA			
Series model	FF 12 DC-M	FF 12 DCB	FF 12 DCB-4
Material options	KP		KT
Pump head	PP		
Diaphragm	EPDM		PTFE
Resonating diaphragm	EPDM		FFKM
Valves	EPDM		FFKM
Flow rate (ml/min)	150		130
Suction height (mWg)	3		2
Pressure head (mWg)	10		
Permissible ambient air (°C)	-5 to 60		
Permissible liquid temperature (°C)	5 to 80		
Weight (g)	60		
IP protection factor	40		
ELECTRICAL DATA			
Operating voltage (V)	12 / 24	12 / 24	10 - 26.4
Power consumption (W)	2.6	1.7 / 1.9	2.1
I load max. (A)	0.22 / 0.11	0.14 / 0.08	0.16 - 0.08

FF 12 DC-M

PERFORMANCE DATA

Series model	Flow rate at atm. pressure (ml/min)	Max. suction height (mWg)	Max. pressure head (mWg)
FF 12 KP DC-M	150	3	10
FF 12 KT DC-M	130	2	10

FF 12 DC-M

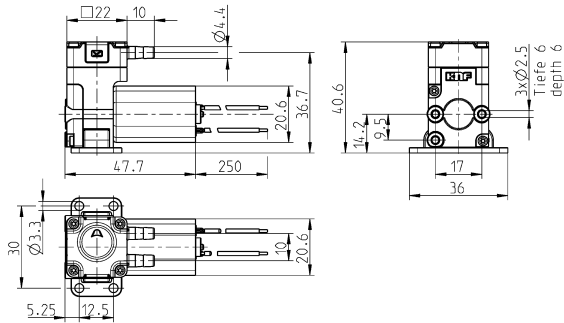

Dimensions in mm

FF 12 DC-M FLOW CURVE

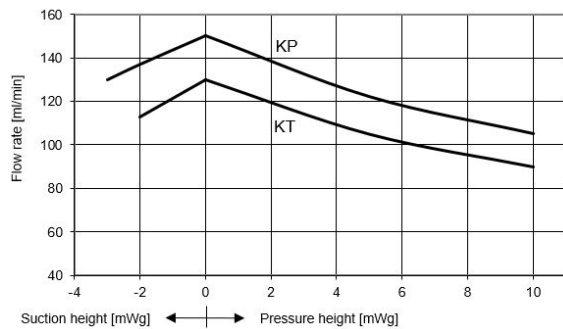

ELECTRONIC SPECIFICATIONS FF 12 DC-M

Wires	AWG 26, L=250 mm
Wire assignment	red: + supply voltage black: - supply voltage

FF 12 DCB

PERFORMANCE DATA

Series model	Flow rate at atm. pressure (ml/min)	Max. suction height (mWg)	Max. pressure head (mWg)
FF 12 KP DCB	150	3	10
FF 12 KT DCB	130	2	10

FF 12 DCB

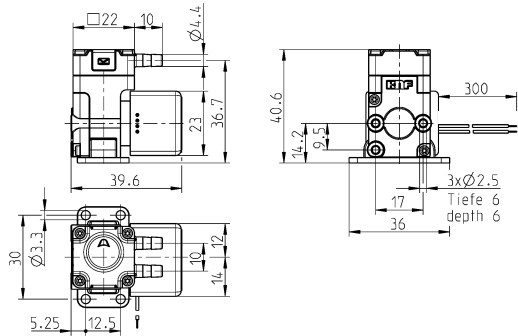

Dimensions in mm

FF 12 DCB-4

PERFORMANCE DATA

Series model	Flow rate at atm. pressure (ml/min)	Max. suction height (mWg)	Max. pressure head (mWg)
FF 12 KP DCB-4	150	3	10
FF 12 KT DCB-4	130	2	10

FF 12 DCB-4

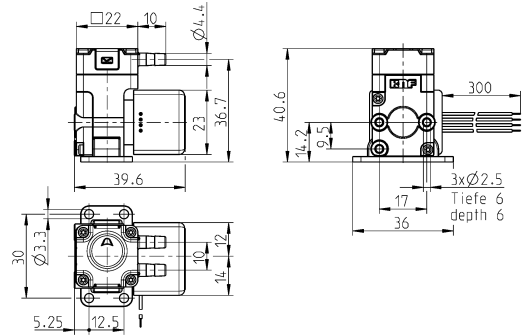

Dimensions in mm

FF 12 DCB FLOW CURVE

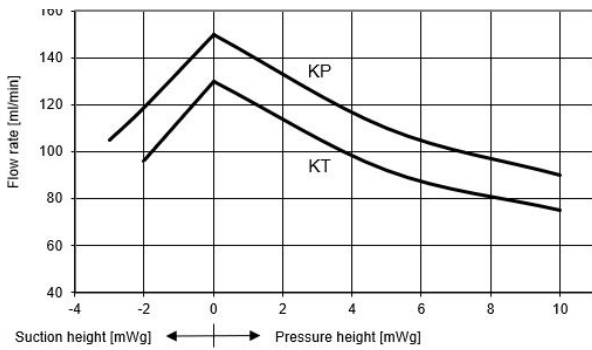

FF 12 DCB-4 FLOW CURVE

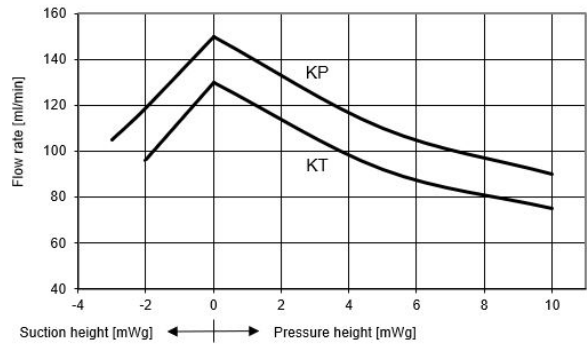

ELECTRONIC SPECIFICATIONS FF 12 DCB

Wires	AWG 28, L=250 mm
Wire assignment	red: + supply voltage black: - supply voltage

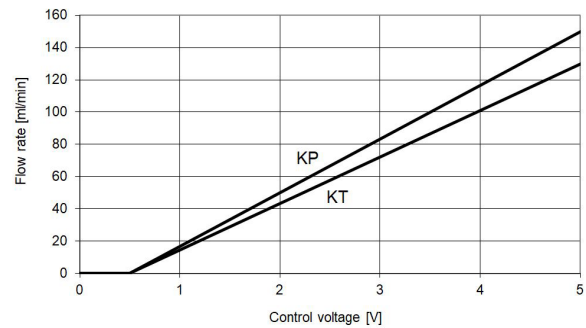

FF 12 DCB-4 CONTROL CURVE



ELECTRONIC SPECIFICATIONS FF 12 DCB-4

Wires	AWG 28, L=250 mm
Wire assignment	red: + supply voltage black: - supply voltage white: control voltage green: rpm output
Input signal	0-5 V

OPTIONS

Description	Illustration	Details
Motors		Various voltage options, higher and lower service life
Electrical connections		Molex, AMP etc.
Hydraulic connections		Internal thread, compression fittings, manifold connection etc.



NSF National Sanitary Foundation

This certification will confirm that all of the pumps with the code .51 are certified for the use with foods/consumables.



Digital customization

Thanks to digital technology, this pump can be quickly adapted to the customer's system. This is done by parametrizing the firmware of the motor at KNF.

ACCESSORIES

Description	Illustration	Details
Mounting plate		Screws included in the set
Diaphragm pressure control valve		The pressure control valve can be used for a more accurate control of flow against a fluctuating back pressure, metering into a vacuum and from a pressurised system.
Pulsation damper		This very versatile pulsation damper reduces the vibration in hoses and pipes and it helps to remove pulsation which is preventing the system from functioning correctly.
Filter		KNF filters protect both pumps and other upstream instrumentation and hydraulic circuits against particulate, crystals and fibres which can improve optimum operation.
Tubing		Various diameters and materials

The performance values for the series models shown on this data sheet were determined under test conditions. The actual performance values may differ and depend in particular on the usage conditions and therefore on the specific application, on the parameters of the components involved in the user's system and on any technical modifications carried out which deviate from the standard configuration or the as delivered condition.

If individual designs have been created for specific customers on the basis of series models, other technical performance data may apply. Before operation begins, the relevant operating instructions and/or assembly or installation instructions should be read and the safety information contained in these instructions should be noted. KNF reserves the right to make changes to the product and the associated documentation without prior notice to the customer.



www.knf.com

KNF reserves the right to make technical changes without notice.
KNF 06/2021 www.knf.com