

PRESSURE

MAX WORKING **1 bar** [14.5 psi]

MATERIALS

EXTERNAL PROTECTION **Anodized aluminum**

TERMINALS **Reinforced nylon**

CENTRAL BODY **Transparent polyamide**

FLOAT **Polyamide**

FIXING SCREWS **Zinc-plated steel**

NUTS **Zinc-plated steel**

SEALS **Buna - Viton**

WORKING TEMPERATURE

BUNA **-30 ÷ 90 °C** [-22 ÷ 195 °F]

VITON **-20 ÷ 110 °C** [-4 ÷ 230 °F]

FLUIDS COMPATIBILITY

MINERAL OILS (1) **HH - HL - HM - HR - HV - HG**

WATER EMULSIONS (1) **HFAE - HFAS**

SYNTHETIC FLUIDS (2) **HS - HFDR - HFDU - HFDS**

(1) With Buna seals

(2) With Viton seals



TECHNICAL FEATURES

- Visual level indicator
- N.C. electrical contact which switches the signal when the float reaches the minimum level
- High impact resistance
- External protection in anodized aluminum

APPLICATION FIELDS



HL98 LEVEL INDICATOR DIMENSIONS

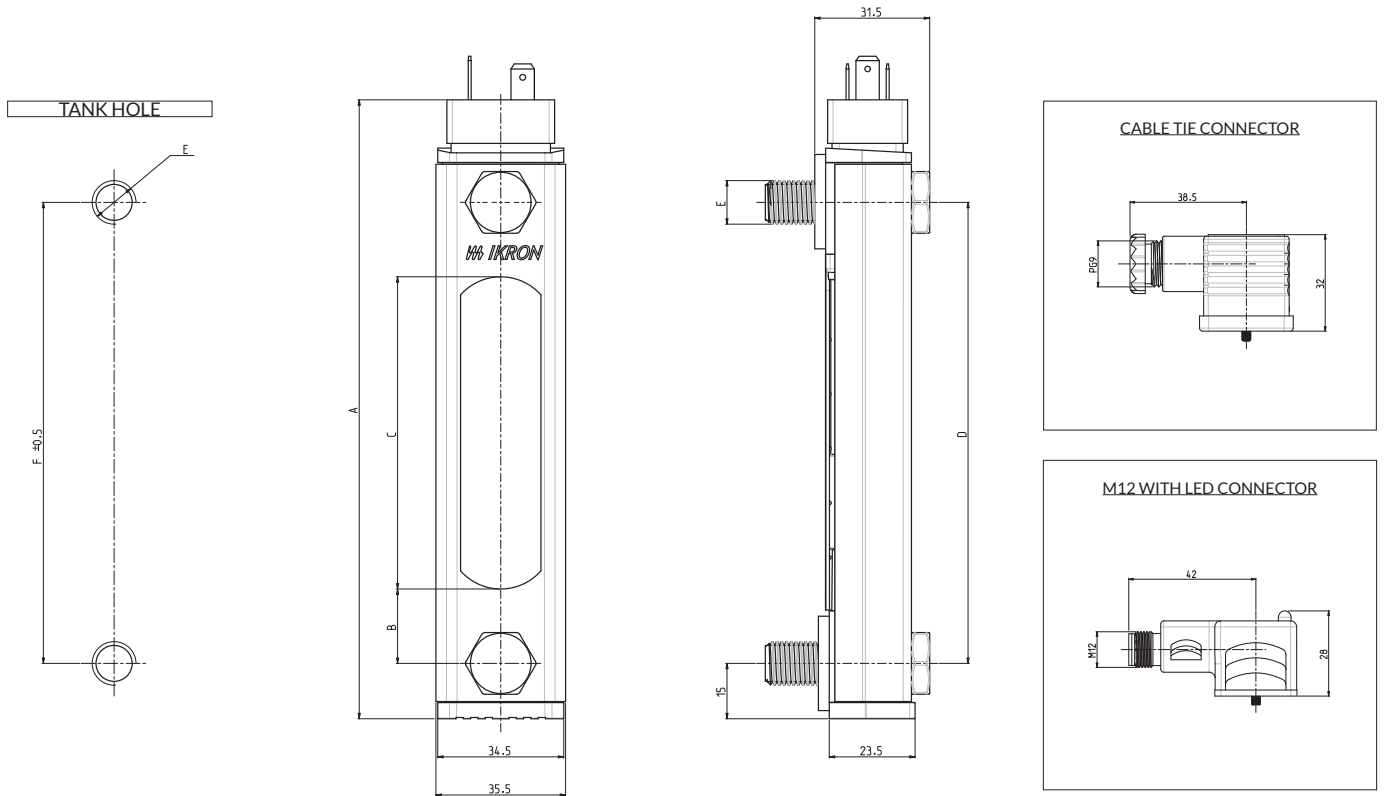

INDICATOR TYPE	WEIGHT	A	B	C	D	E	F
	kg [lb]	mm [in]	mm [in]	mm [in]	mm [in]	thread	mm [in]
HL98-20	0,17 [0.37]	170 [6.8]	20,5 [0.82]	86 [3.44]	127 [5.08]	M10 M12	127 [5.08]
HL98-30	0,21 [0.46]	294 [11.76]	20,5 [0.82]	213 [8.52]	254 [10.16]	M10 M12	254 [10.16]

MOUNTING INSTRUCTIONS

The assembly of the HL 98 level indicators takes place through the built-in screws which must be screwed with a tightening torque of 10 Nm to the corresponding threaded seats on the tank. After having tightened the two screws supplied, proceed with the connection of the electrical connector.

BUILD YOUR LEVEL INDICATOR

Write here



1	HL98	INDICATOR TYPE	
2		DIMENSION	
	Dimension	20	30
3		FIXING SCREWS	
	M 10	T1	T1
	M 12	T2	T2
4		SEALS	
	Buna	B	B
	Viton	V	V
5		CONNECTOR	
	Cable tie	S	S
	M12 with Led	M	M

► For special requests please contact our Sales Department.

SUCTION FILTERS

**HF410
HF431/434/437**

RETURN FILTERS

**HF502/508
HF510
HF532
HF547
HF554
HF570/575/578**

SUCTION AND RETURN FILTERS

**HF535
HF595**

SPIN-ON FILTERS

**HF620/625
HF650**

MEDIUM AND HIGH PRESSURE FILTERS

**HF690
HF705
HF710
HF725
HF735
HF745
HF749
HF760**

HAND PUMPS

**EP15/25/45
TXA**

ACCESSORIES

**HB50/70/110/120
AF105/106
HBO2/HL91/HL98
CLOGGING INDICATORS**

FILTRATION DEVICES

**FLUX OIL IK15/50
R15/50**



Via C. Prampolini, 2
43044 Lemignano di Collecchio
Parma - Italy
Phone: +39 0521 304911
info@ikron.it
www.ikron.it

