

HLS-L

DISPLACEMENT SENSOR LINEAR WIRE ENCODER



- Measuring Range 6000~10000 mm
- Push Pull, Line Driver
- DC 5~26V

DIMENSION

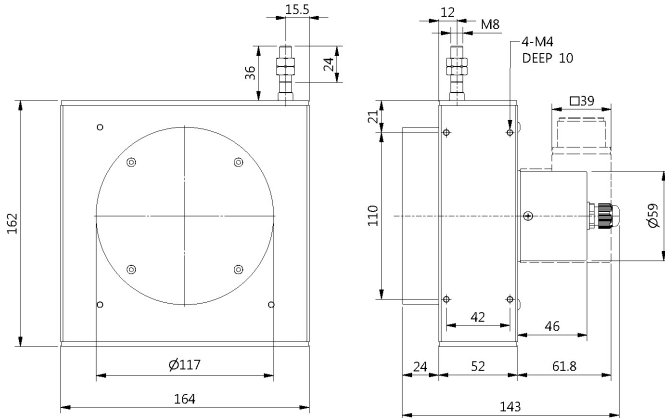

ORDERING INFORMATION

HLS-L-	Stroke 行程	Resolution 解析	Electronics 電路特性	Male Connector 連接器
	60 : 6000 mm	1 : 1 mm	P: Push Pull	*R7: 7 pin
	80 : 8000 mm	05 : 0.5 mm	*H: Line Driver	*R10: 10 pin
	100 : 10000 mm	02 : 0.2 mm		
	120 : 12000 mm	01 : 0.1 mm		

*OPTION
(Std.) Cable Length 1 m output

ELECTRICAL SPEC.

Detection System	Incremental 增量型
Output Wave 輸出波形	Square Wave 方波
Stroke (mm) 量測行程	6000, 8000, 10000, 12000
Standard Resolution (mm/pulse) 解析	1, 0.5, 0.2, 0.1 mm/pulse
Repeatability Error 重複性誤差	±0.05% FS, ±1 count
Output Phase 輸出相	ABZ phase
Electronics 電路特性	Push Pull or Line Driver
Power Supply 供應電源	DC 5~26V
Current Consumption 消耗電流	≤ 60 mA
Output Capacity 輸出容量	Sync. Current: 20 mA, Residual Voltage: 0.5V or less
Max. Response 最大響應頻率	10K Hz ~ 50K Hz
Phase Different 相位差	A, B phase different 90°±45° (T/4±T/8), Z phase T±T/2
Wave Form Rise / Fall 波形上下時間	2 μs or less
Polarity 極性保護	Against Reverse Protection

MECHANICAL SPEC.

Wire Specification 線徑規格	Material: SUS304 with nylon coating Diameter: 1.0 mm; Breaking load: 60 Kg
Max. Travel Speed 最大往復速度	1,000 mm / sec.
Vibration 震動	10g (10±1,500 Hz)
Shock 衝擊	20g per 11 ms
Cable 電線	Ø5.4, 100 cm long
Weight 重量	< 3,500g
Starting Torque on Spring 拉力	1500 ~ 2000 g

ENVIRONMENTAL SPEC.

Operating Temp. / Humidity 操作溫度/濕度	0°C ~ 60°C, RH 35% ~ 90% (No Condensation)
Storage Temp. 儲存溫度	-20°C ~ 80°C
Protection 保護等級	IP64: Dust & Dripping Proof (only for encoder housing)
Life 壽命	Typical > 1 X 10 ⁶ cycles