

HLS-S

DISPLACEMENT SENSOR LINEAR WIRE ENCODER



- Measuring Range 1000 mm
- Push Pull, Line Driver
- DC 5~26V

DIMENSION

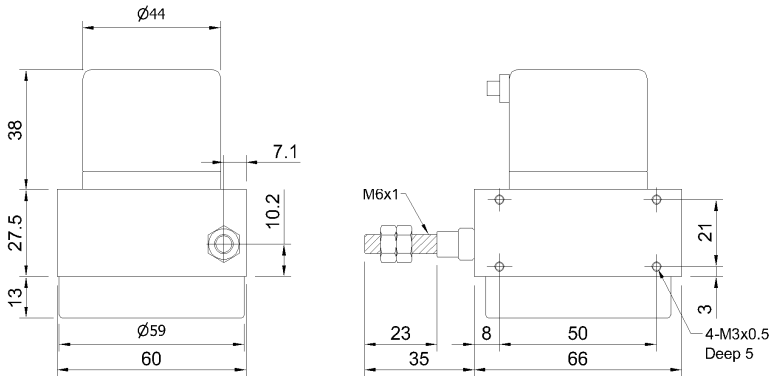

ORDERING INFORMATION

HLS-S-10 -		A -	
	Resolution 解析		Electronics 電路特性
	1 : 1 mm		P: Push Pull
	05 : 0.5 mm		*H: Line Driver
	02 : 0.2 mm		
	01 : 0.1 mm		
	004 : 0.04 mm		

ELECTRICAL SPEC.

Detection System	Incremental 增量型
Output Wave 輸出波形	Square Wave 方波
Stroke (mm) 量測行程	1000
Standard Resolution (mm/pulse) 解析	1, 0.5, 0.2, 0.1, 0.04 mm/pulse
Repeatability Error 重複性誤差	±0.05% FS, ±1 count
Output Phase 輸出相	ABZ phase
Electronics 電路特性	Push Pull or Line Driver
Power Supply 供應電源	DC 5~26V
Current Consumption 消耗電流	≤ 60 mA
Output Capacity 輸出容量	Sync. Current: 20 mA, Residual Voltage: 0.5V or less
Max. Response 最大響應頻率	Max. 100K Hz
Phase Different 相位差	A, B phase different 90°±45° (T/4±T/8), Z phase T±T/2
Wave Form Rise / Fall 波形上下時間	2 µs or less
Polarity 極性保護	Against Reverse Protection

MECHANICAL SPEC.

Wire Specification 線徑規格	Material: SUS304 with nylon coating Diameter: 0.6 mm; Breaking load: 16 Kg
Max. Travel Speed 最大往復速度	1,000 mm / sec.
Vibration 震動	Max. 10g (10 ~55 Hz / 1.5 mm X.Y.X. 2Hr)
Shock 衝擊	20g per 11 ms
Cable 電線	Ø4.5, 50 cm long
Weight 重量	< 450g
Starting Torque on Spring 拉力	Max. 700 g

ENVIRONMENTAL SPEC.

Operating Temp. / Humidity 操作溫度/濕度	0°C ~ 60°C, RH 35% ~ 90% (No Condensation)
Storage Temp. 儲存溫度	-20°C ~ 70°C
Protection 保護等級	IP50: Dust Proof (only for encoder housing)
Life 壽命	Typical > 1 X 10 ⁶ cycles