

EMAX2

Magnetic Absolute Linear Encoder with Distance Detection

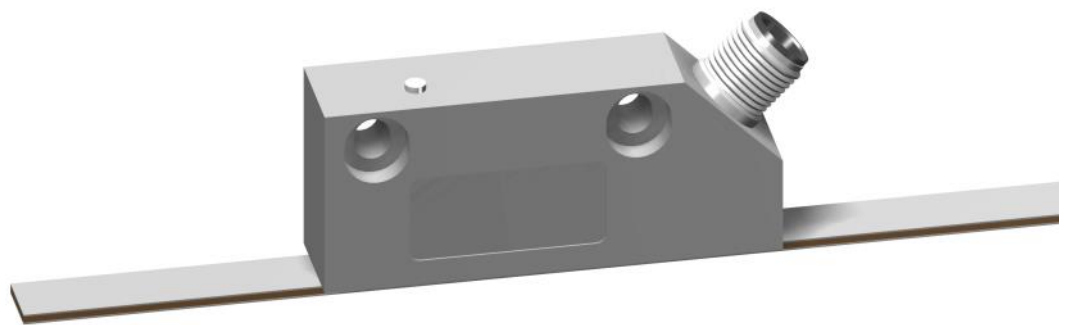

- Absolute encoder with 10 μm resolution
- Direct and contact free measurement
- Measuring length up to 10 m possible
- No referencing required (position changes are also recognized in the de-energized state)
- Too large distances between sensor and magnetic tape are detected automatically and signaled by an LED
- Additional incremental square wave or sine-cosine signals for dynamic movement control available
- Available interfaces are SSI (binary or Gray code), RS422, addressable RS422, CANopen (DS406) or CAN with basic ELGO protocol

EMAX2 - Magnetic Absolute Linear Encoder with Distance Detection

General

The **EMAX2** series is an absolute length measuring system. Sensor, translator and interpolation unit are placed together in a compact zinc die-cast housing. The absolute coded magnetic tape is paste up to a plain area. The **EMAX2** encoder can be mounted with a maximum distance of 1.5 mm to the magnetic tape. With a reduced measuring accuracy the sensor distance can be up to 2.0 mm. The measuring length of the **EMAX2** can be up to 10 meters.

Advantages

An important advantage of the **EMAX2** is the compact design, which makes the system equally suitable for retrofitting into existing plants as well as for new installations. Due to the absolute measuring principle, the zero point only needs to be set once. Then no further referencing is required. Furthermore, the measuring system impresses with its non-contact and completely wear-free scanning and insensitivity to dust and dirt. To meet the higher degree of protection IP65, the **EMAX2** sensor can be supplied as sealed version (option V).

Interfaces

The **EMAX2** sensors can be equipped with different interfaces. It is possible to choose between SSI (optionally as Gray or binary code), RS422 resp. addressable RS422 or CANopen according to the "DS406" encoder profile or CAN interface according to the ELGO CAN standard protocol.

Product Features

- Absolute Measurement: no referencing required, position changes are also recognized in the de-energized state
- Resolution 0.01 mm
- Contactless measuring principle
- Measuring length up to 10 m possible
- Automatic distance monitoring: Too large distances between sensor and magnetic tape are signaled by an LED
- Additional incremental square wave or 1 Vpp sine-cosine signals for dynamic movement control available

Automatic distance monitoring:
In case of an incorrect distance to the tape, the LED lights up red.

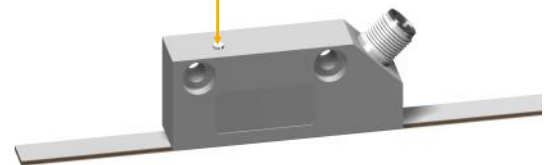

Applications

Typical applications are handling systems, conveyor and storage technology, hydraulic presses, stamping machines, casting machines, linear slides, linear drives and pick and place systems.

Functional Principle

A Hall sensor and a magneto-resistive impedance measuring bridge are guided over a two-track magnetic tape with a fine-interpolation trace and an absolute trace. Together with the sensor line the absolute track provides an absolute value and the fine-interpolation trace provides together with the interpolation electronic the measuring systems high resolution.

The fine interpolation trace encloses alternately north and south pole traces with a distance of 5 mm, which are scanned with resistance bridges and provide a resolution of 0.01 mm. The absolute value provides the sensor line with 16 single Hall sensors; these sensors are scanning the code sections of the north and south poles. The absolute value on the magnetic tape repeats itself every 10 m with **EMAX2**.

Measurement principle and dual-track encoding of the Magnetic Tape

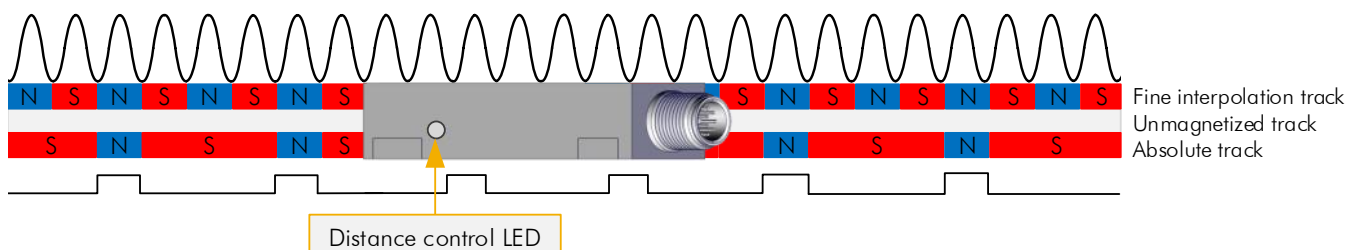

EMAX2 - Magnetic Absolute Linear Encoder with Distance Detection

Technical Data

EMAX2 (Standard Version)

Mechanical Data

Measuring principle	absolute
Measurement	linear
Repeat accuracy	± 1 increment
System accuracy in μm at 20° C	010 ($\pm 150 + 20 \times L$) F10 ($\pm 75 + 20 \times L$) L = measuring length in meters
Distance from sensor to the magnetic tape	max. 1.5 mm (2.0 mm with reduced measuring accuracy)
Basic pole pitch	5 mm
Sensor housing material	Zinc die-cast
Housing dimensions	L x W x H = 70 x 16 x 30 mm
Required magnetic tape	AB20-50-10-2-R-11
Measuring length	up to 10 m
Connection	12 pin M12 round connector (external)
Sensor cable	as Accessory (standard length = 5 m)
Weight	sensor: approx. 50 g (without cable) cable: approx. 60 g / m (accessory)

Electrical Data

Power supply voltage	+ 10 ... 30 VDC
Residual ripple	< 10 %
Current consumption	max. 150 mA
Interfaces	SSI, CAN or RS422 (see type designation)
Resolution	0.01 mm
Operating speed	max. 4 m/s

Environment Conditions

Storage temperature	-20 ... +85° C
Operation temperature	-10 ... +70° C (-20 ... +85° C on request)
Humidity	max. 95 %, not condensing
Protection Class	IP40 (Standard) IP65 (Option V)

Type Designation

For orders, please use the following order code:

EMAX2 AA BB CCC DDD EEEE F GGGG H I JJJJ

A SN Number

- 00 = standard version
- 01 = first customer-specified version

B Signal Cable Length (in m)

- 00 = standard without signal cable
(available as accessory, see last page)

C Resolution in μm

- 010 = 10 μm at system accuracy in $\mu\text{m} \pm (150 + 20 \times L)$
- F10 * = 10 μm at system accuracy in $\mu\text{m} \pm (75 + 20 \times L)$
* Variant F10 with surcharge

D Interface

- SBO = SSI interface (25 bit binary code)
- SG0 = SSI interface (25 bit Gray code)
- CA0 = CANopen (DS406)
- CN0 = CAN BASIC ELGO
- 420 = RS422
- A20 = addressable RS422

E Bit rate

- 09K6 = 9600 Bit/s with RS422 (standard)
- 19K2 = 19200 Bit/s with RS422
- 38K4 = 38400 Bit/s with RS422
- 125k = 125000 bit/s with CAN
- 250k = 250000 bit/s with CAN
- 500k = 500000 bit/s with CAN
- 1MHz = 1000000 bit/s with CAN

Additional Options

- F Address = device address 0.. F (standard setting: 0)
- G ---- = standard generally with 12-pin round connector on sensor housing (fixed cable outlet on request)
- H V = sealed IP65 version
- I A = without termination resistor (CAN and A20 interface)

J Additional Incremental Signals

- H2N5 = HTL square wave signals with 2,5 μm resolution
- H005 = HTL square wave signals with 5 μm resolution
- H010 = HTL square wave signals with 10 μm resolution
- H025 = HTL square wave signals with 25 μm resolution
- T2N5 = TTL square wave signals with 2,5 μm resolution
- T005 = TTL square wave signals with 5 μm resolution
- T010 = TTL square wave signals with 10 μm resolution
- T025 = TTL square wave signals with 25 μm resolution
- SC50 = 1 Vpp Sine-Cosine signals with 5 mm pole pitch

Note: Please fill in „-“ for ordering options which are not desired.

Order example:

EMAX2 00 01 010 CA0 250K 0 - - - - V A T005
AA BB CCC DDD EEEE F GGGG H I JJJJ

ELGO standard EMAX2 with 1 m cable, 10 μm standard resolution, CANopen (DS406) interface with 250000 bit/s, standard device address „0“, as sealed IP65 construction, without termination resistor and with TTL square wave signals with 5 μm resolution.

Your order:

EMAX2 _____ - - - -
AA BB CCC DDD EEEE F GGGG H I JJJJ

Dimensions:

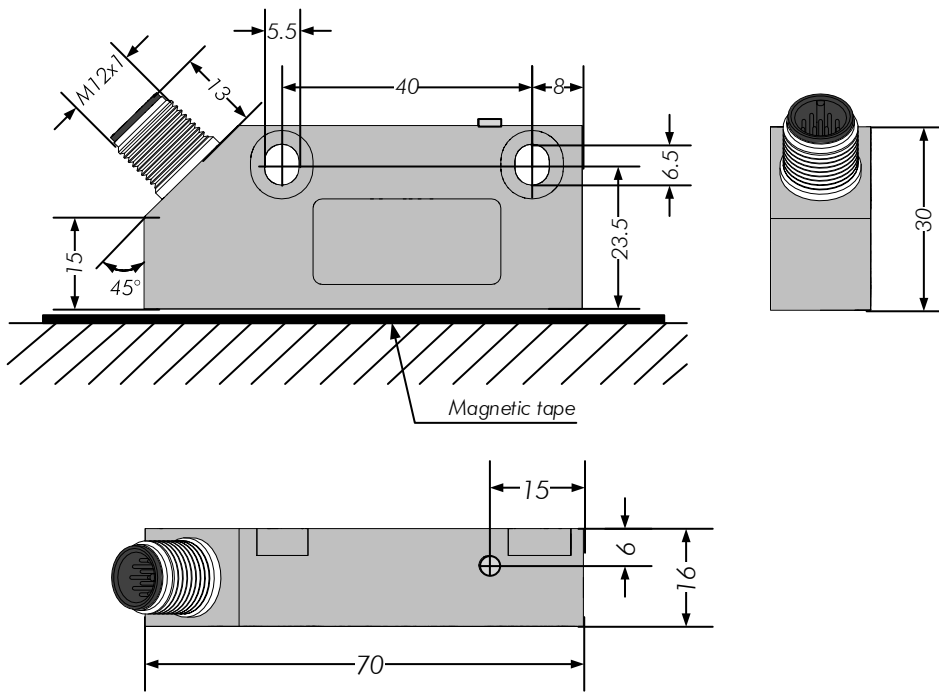

Mounting tolerances:

Sensor distance

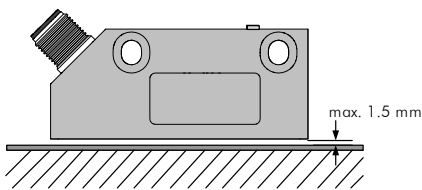

Roll

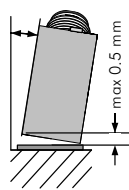

Yaw angle

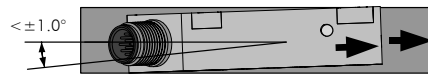

Pitch

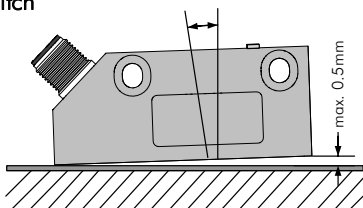

Lateral offset

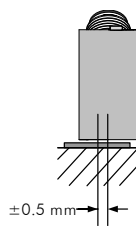

Accessories:

Order designation	Description
AB20-50-10-2-R-11	Absolute encoded magnetic tape for EMAX2 (max. measuring length 10 m)
Magnetic tape end cap set 10 mm	2 end caps (10 mm) and 2 x M3 screws; Additional fixation for linear or radial application, as well as for protection of magnetic tape ends. Art. No. 731031002
FS-1000, FS-1500, FS-2000	Guide rails for EMAX2 (length indication in mm)
PNO1	SSI / PROFIBUS converter
DKA-00-RCF0-050-XXXX-12-T-D-S	Connection cable for EMAX2 with RCF0 = female M12 round connector, 050 = 5.0 m standard cable length, 12 = 12-pin M12 round connector (female), T = twisted pairs, D = drag chain suitable, S = with screen/shield

