

Your Advantages

- More space in the control cabinet due to compact design
- Provision of measured values via Modbus

Features

- Continuous scanning of voltages and currents in 3-phase networks with neutral conductor (IT, TN or TT systems)
- Measurement of effective and peak values of phase voltage and phase current as well as mains frequency, power factor, active power, reactive power, apparent power, active energy, reactive energy and apparent energy
- Galvanic separated Modbus RTU interface
- Simple setting of Modbus address and baud rate on the device
- Current transformers ratio adjustable via Modbus
- Permanent storage of the measured energy values in the device
- No separate auxiliary voltage necessary (generated from the measured voltage of all three phases)
- Width: 35 mm

Product Description

The energy meter RL 9405 of the VARIMETER PRO series is consumed for measuring electrical parameters and energy consumption in 3-phase networks with neutral conductor. Voltages and currents are continuously scanned and evaluated. The measured values can be read out via a Modbus RTU interface.

Due to its compact design width of only 35 mm, the energy meter ist also ideally suited for use in confined spaces.

Energy consumptions are stored in the device after switching off the supply voltage. The RL 9405 is designed for the use of current transformers with 100 mA, 1 A or 5 A secondary rated current. The winding ratio is adjustable via Modbus and thus enables the connection of commercially available current transformers. The device is consumed in energy distribution systems and IT data centers for consumption monitoring.

Approvals and Markings



Applications

- Measurement and calculation of electrical values such as voltage, current, power and energy in low voltage networks
- Installation of the device in cabinets or consumer units

Indicators

- Green LED ON: On, when supply voltage connected
- Yellow LED BUS: Shows RS485 bus activity

Connection

The device is supplied via the measuring voltage inputs. It has an RS485 interface and works with the Modbus RTU protocol.

Connection Terminals

Terminal designation	Signal description
L1, L2, L3, N	Measuring voltage inputs, supply voltage
i1, k1, i2, k2, i3, k3	Current measuring inputs
GND, A, B	RS485 interface

Notes

Attention !



The energy meter RL 9405 ist not an energy meter for consumption of active power as defined in the EU 2004/22/EC (MID). The energy meter may therefore not be used for billing purposes.

Circuit Diagrams

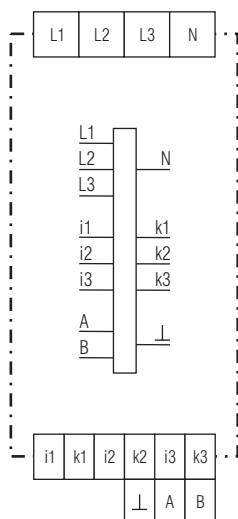

Setting Facilities

Potentiometer ADR10:	- Unit address x 10
Potentiometer ADR1:	- Unit address x 1
Potentiometer kBit/s:	- Baud rate in kBit/s

The Modbus devices are connected in a line bus structure (see connection example). Up to 32 bus devices can be connected to the bus. The beginning and the end of a segment are terminated with a terminating resistor (120 Ohm). The bus termination is usually done at the bus master and at the last device in the chain. The energy meter itself does not have a terminating resistor.

The device distinguishes between consumed and delivered active energy and accumulates both quantities separately. In the case of reactive energy a distinction is made between inductive and capacitive reactive energy and is also accumulated separately.

Before switching off the supply voltage, the device stores all energy values non-volatile in the device. When the device is switched on again, these values will be reactivated and consumed as start value for further energy measurement. The trigger for the storage of the energy values is a drop of all three phase voltages below AC 80 V for at least 50 ms.

In addition the device detects a voltage drop of more than 20 V per 100 ms and sets a status bit for this state. This can be read out via Modbus and thus react to an impending loss of supply voltage.

Technical Data

Measuring voltage input

Operating voltage U_B:	3/N AC 80 ... 276 V / 140 ... 480 V
Voltage rated operating U_c:	3/N AC 80 ... 230 V / 140 ... 400 V
Nominal frequency:	50 Hz (60 Hz on request)
Measuring accuracy:	$\pm 0,5 \%$
Nominal consumption:	Approx. 1 VA

Measuring current input

Inputs for current measurement.: Not galvanically isolated, external current transformers are required for current measurement

Operating current I_B:	
RL 9405:	0 ... 100 mA
RL 9405/100:	0 ... 1 A
RL 9405/500:	0 ... 5 A

Power consumption

current transformer input:

RL 9405:	0.5 VA
RL 9405/100:	0.5 VA
RL 9405/500:	0.6 VA

Measuring range with ext.

current transformers: 0 ... 1000 A

Rated output current of the transformers:

RL 9405:	100 mA
RL 9405/100:	1 A
RL 9405/500:	5 A

Min. current: 0.05 % of
Rated output current x current transformer ratio

Nominal frequency:

Overload (for 0.5 s):

RL 9405:	2 A (sinusoidal)
RL 9405/100:	20 A (sinusoidal)
RL 9405/500:	100 A (sinusoidal)

Measurement accuracy: $\pm 0,5 \%$

RS485 Bus

Protocol:	Modbus RTU
Terminals:	┘, A, B
Bus connection:	Galvanic separation
Slave address:	1 to 99
Baud rate:	9600, 19200, 38400, 57600, 115200 Baud

General Data

Nominal operating mode: Continuous operation

Temperature range

Operation:	- 20 ... + 55 °C
Storage:	- 20 ... + 55 °C

Relative air humidity: 93 % at 40 °C

Altitude: ≤ 2000 m

Clearance and creepage distance

Rated impulse voltage / pollution degree (measuring input to bus): 6 kV / 2 IEC 60664-1

EMC

Electrostatic discharge (ESD):	8 kV (air)	IEC/EN 61000-4-2
HF-irradiation		
80 MHz ... 1 GHz:	10 V / m	IEC/EN 61000-4-3
1 GHz ... 2 GHz:	3 V / m	IEC/EN 61000-4-3
2 GHz ... 2.7 GHz:	1 V / m	IEC/EN 61000-4-3
Fast transients:	2 kV	IEC/EN 61000-4-4
Surge voltages between		
wires for power supply:	2 kV	IEC/EN 61000-4-5
Between wire and ground:	4 kV	IEC/EN 61000-4-5
HF-wire guided:	10 V	IEC/EN 61000-4-6

Technical Data

Interference suppression:	Limit value class A The device is designed for the usage under industrial conditions (Class A, EN 55011). When connected to a low voltage public system (Class B, EN 55011) radio interference can be generated. To avoid this, appropriate measures have to be taken.	
Degree of protection		
Housing:	IP 40	IEC/EN 60529
Terminals:	IP 20	IEC/EN 60529
Housing:	Thermoplastic with VO behaviour according to UL Subject 94	
Vibration resistance:	Amplitude 0.35 mm, Frequency 10 ... 55 Hz, IEC/EN 60068-2-6 20 / 055 / 04 IEC/EN 60068-1	
Climate resistance:	EN 50005	
Terminal designation:	DIN 46228-1/-2/-3/-4	
Wire connection:		
Fixed screw terminals		
Cross section:	0.2 ... 4 mm ² (AWG 24 - 12) solid or 0.2 ... 2.5 mm ² (AWG 24 - 12) flexible with and without ferrule	
Stripping length:	7 mm	
Wire fixing:	Captive slotted screws M2.5	
Fixing torque:	0.6 Nm	
Mounting:	DIN-rail	IEC/EN 60715
Weight:	Approx. 105 g	

Dimensions

Width x height x depth: 35 x 90 x 71 mm

Standard Type

RL 9405 3/N AC 80 ... 230 V	50 Hz
Article number:	0069092
• Operating voltage U _B :	3/N AC 80 ... 230 V
• Secondary current:	100 mA
• Nominal frequency:	50 Hz
• Width:	35 mm
ND 5013/024 (on request)	
Article number:	0069465
• Current transformer for RL 9405	
• Primary current:	50 A
• Secondary current:	100 mA
• Diameter:	24 mm

Variants

RL 9405/100 3/N 80 ... 230 V	50 Hz
Article number:	0069519
• Operating voltage:	3/N AC 80 ... 230 V
• Secondary current:	1 A
• Nominal frequency:	50 Hz
• Width:	35 mm
RL 9405/500 3/N 80 ... 230 V	50 Hz
Article number:	0069520
• Operating voltage:	3/N AC 80 ... 230 V
• Secondary current:	5 A
• Nominal frequency:	50 Hz
• Width:	35 mm

Ordering example for variants

RL 9405 / _ 0 0 3/N AC 80 ... 230 V 50 Hz

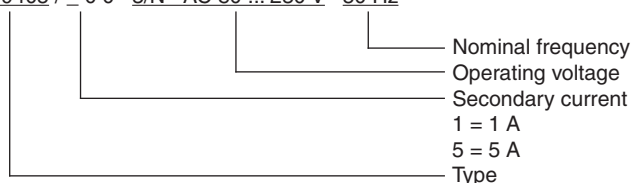

Modbus RTU

For communication between Energy meter and a supervising control the Modbus RTU protocol according to Specification V 1.1.b3 is consumed.

Bus Interface

Protocol	Modbus Seriell RTU
Address	1 to 99
Baud rate	9600, 19200, 38400, 57600, 115200 Baud
Data bit	8
Stop bit	2
Parity	none

More information about the interface, wiring rules, device identification and communication monitoring can be found in the Modbus user manual.

Device configuration

If required the device configuration data can be saved permanently by setting the the Bit "Write configuration to EEPROM". The maximum number of storage operations is limited to around 1 million write cycles. When the auxiliary voltage is applied, the data are copied from the EEPROM into the corresponding parameter registers. In addition, please note that when the EEPROM is written, the data is stored for approx. 50 ms no Modbus telegrams can be received.

Function-Codes

In the RL 9405 the following function codes are implemented

Function-Code	Name	Description
0x03	Read Holding Register	Device parameter read word by word
0x04	Read Input Registers	Device status, device identification and measured energy value read word by word or in blocks
0x06	Write Single Register	Device parameter write word by word
0x10	Write Multiple Registers	Device parameter write in blocks

With the Modbus functions Write Single Register or Write Multiple Registers the following functions are possible:

- Resetting all energy measured values
- Selection of the current transformer winding ratio
- Selection of the energy meter data format for the measured values: 32/64-bit integer or 32-Bit floating point representation acc. to IEEE 754
- Writing the device parameters to the EEPROM

Connection Example

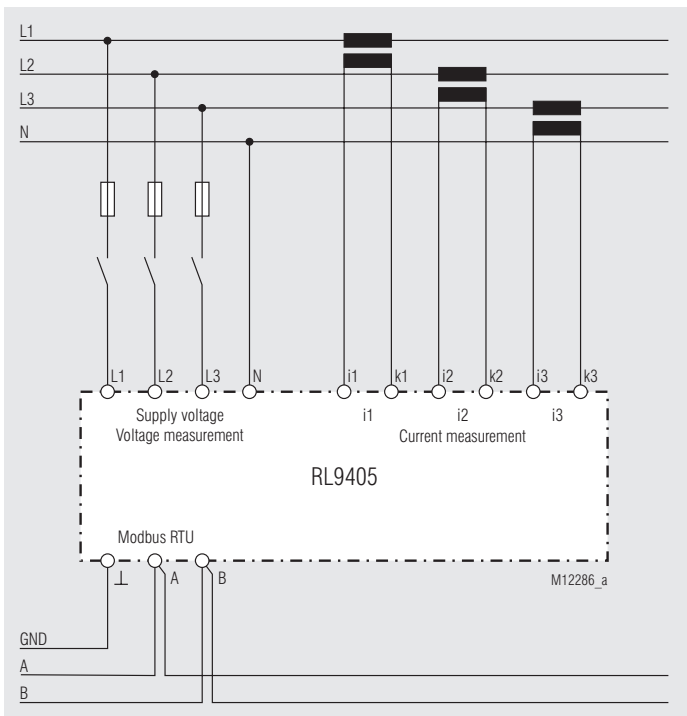

Accessories

Measuring current transformer ND 5013/024 (on request)

- The Measuring current transformer ND 5013/024 is designed for DIN rail mounting or screw-type mounting
- Mounting on the top-hat rail may be done horizontally or vertically

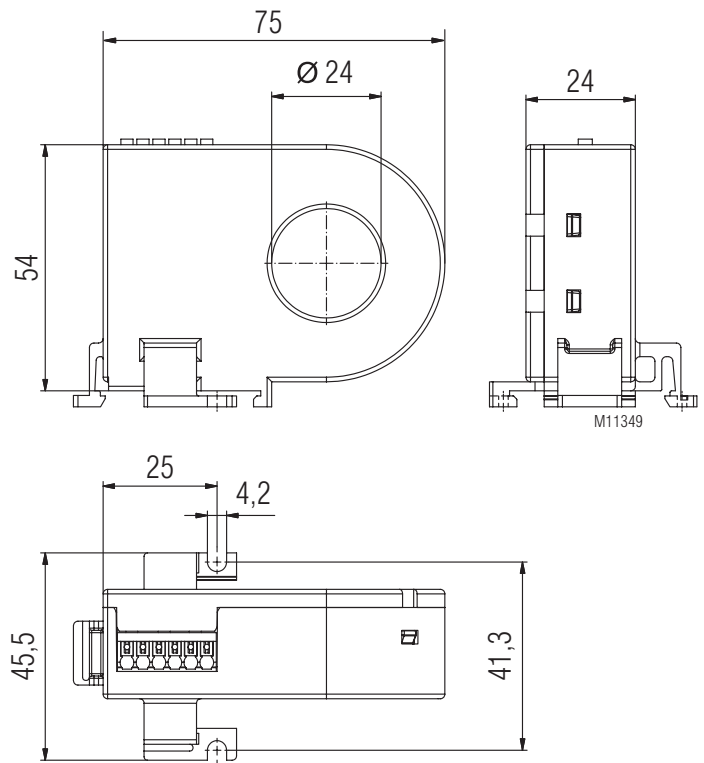

Technical Data Measuring Current Transformer ND 5013/024

Accuracy class:	0.5 S
Highest rated operating voltage:	300 V (Base insulation)
Rated nominal current	
Primary:	50 A
Secondary:	0.1 A
Rated transformation ratio:	1 : 500
Rated power:	0.5 VA
Burden:	4.7 Ω
Rated frequency:	50 Hz
Temperature range:	- 20 ... + 60 °C
Rated impulse voltage:	3 kV
Housing:	Thermoplastic with VO behaviour acc. to UL subject 94
Vibration resistance:	Amplitude 0.35 mm frequency 10...55 Hz, IEC/EN 60068-2-6
Climate resistance:	20 / 060 / 04
Wire connection	0.2 ... 1.5 mm ²
Stripping length:	8 mm
DIN rail mounting:	Integrated clips for vertical and horizontal mounting
Screw fixing:	M3 or M4
Fixing torque:	Max. 0.8 Nm
Weight:	95 g

Calculation Formulas For The Determination Of Measured Values

Explanations of the measured values

V_{Li} : Voltage phase L_i

I_{Li} : Current phase L_i

V_{L90i} : Voltage phase L_i shifted by 90°

N : Number of measured values during one measuring cycle

Measured value	Calculation formulas	Remark
RMS voltage effective	$V_{rms\ i} = \sqrt{1/N * \sum (V_{Li})^2}$	
RMS current effective	$I_{rms\ i} = \sqrt{1/N * \sum (I_{Li})^2}$	
Voltage peak	$V_{peak\ i} = \sqrt{2} * V_{rms\ i}$	
Current peak	$I_{peak\ i} = \sqrt{2} * I_{rms\ i}$	
Power Factor	PowerFaktor = $ P_{act\ i} / P_{app\ i} $	
Active power	$P_{act\ i} = 1/N * \sum V_{Li} * I_{Li}$	
Reactive power	$P_{react\ i} = 1/N * \sum V_{L90i} * I_{Li}$	
Apparent power	$P_{app\ i} = \sqrt{(P_{act\ i})^2 + (P_{react\ i})^2}$	
Active energy (consumed)	$E_{act\ con\ i} = \Delta t * \sum P_{act\ i} $	Energy values are accumulated for $P_{act\ i} > 0$ and remain constant for $P_{act\ i} < 0$
Active energy (delivered)	$E_{act\ del\ i} = \Delta t * \sum P_{act\ i} $	Energy values are accumulated for $P_{act\ i} < 0$ and remain constant for $P_{act\ i} > 0$
Reactive energy (inductive)	$E_{react\ ind\ i} = \Delta t * \sum P_{react\ i} $	Energy values are accumulated for $P_{react\ i} (n) > 0$ and remain constant for $P_{react\ i} (n) < 0$
Reactive energy (capacitive)	$E_{react\ cap\ i} = \Delta t * \sum P_{react\ i} $	Energy values are accumulated for $P_{react\ i} < 0$ and remain constant for $P_{react\ i} > 0$
Apparent energy	$E_{app\ i} = \sqrt{(E_{act\ i})^2 + (E_{react\ i})^2}$	Accumulates the positive energy values of $E_{act\ i}$ and $E_{react\ i}$
Total active power	$P_{act} = \sum P_{act\ i}$	
Total reactive power	$P_{react} = \sum P_{react\ i}$	
Total apparent power	$P_{app} = \sum P_{app\ i}$	
Total active energy (consumed)	$E_{act\ con} = \sum E_{act\ con\ i} - \sum E_{act\ del\ i}$	Energy values are accumulated for $E_{act\ con} > 0$ and remain constant for $E_{act\ con} < 0$
Total active energy (delivered)	$E_{act\ del} = \sum E_{act\ del\ i} - \sum E_{act\ con\ i}$	Energy values are accumulated for $E_{act\ del} > 0$ and remain constant for $E_{act\ del} < 0$
Total reactive energy (inductive)	$E_{react\ ind} = \sum E_{react\ ind\ i} - \sum E_{react\ cap\ i}$	Energy values are accumulated for $E_{react\ ind} > 0$ and remain constant for $E_{react\ ind} < 0$
Total reactive energy (capacitive)	$E_{react\ cap} = \sum E_{react\ cap\ i} - \sum E_{react\ ind\ i}$	Energy values are accumulated for $E_{react\ cap} > 0$ and remain constant for $E_{react\ cap} < 0$
Total apparent energy	$E_{app} = \sum E_{app\ i}$	

Parameter Table

Every slave owns an output- configuration- and actual value table. In these tables it is defined under which address the parameters can be found.

Holding Register (Device configuration):

Register-Address	Protocol-Address	Name	Value range	Description	Data type	Access rights
40001	0	Device control	1 ... 4	Bit 0: Reset Bit 2: Write configuration to EEPROM	UINT16	write/read
42001	2000	Current transformer winding ratio	1 ... 10000	Current transformer winding ratio	UINT16	write/read
42002	2001	Energy values Data format	0 ... 1	0: Integer 1: Floating Point	UINT16	write/read

In the delivery state, a current transformer turns ratio of 1:500 and the loading point format for the energy values are set.

Example current transformer configuration

The following example configures the current transformer ratio of the ND 5013/024 current transformer.

Rated nominal currents:

Primary current: 50 A
Secondary current: 0.1 A

The current transformer turns ratio of 50 A/0.1 A = 500 can be determined on the basis of these two specifications.

This value is written to the holding register with the protocol address 2000 via Modbus using the commands Write Single Register (function code 0x06) or Write Multiple Registers (function code 0x10).

Telegram example for the configuration of a slave with slave address 9:

Slave Address	Function Code	Register Address	Register Value	CRC 16
0x09	0x06	0x07 0xD0	0x01 0xF4	0x88 0x18

Parameter Table

Input Register (Device state):

Register-Address	Protocol-Address	Name	Value range	Description	Data type	Access rights
30001	0	Device failure	0 ... 10	0: No failure 1: Supply voltage drop > 20 V / 100 ms 9: Communication fault Modbus 10: Checksum failure EEPROM	UINT16	read
30002	1	State of device	0 ... 2	0: Device initialize 1: Device is ready 2: Device in error mode	UINT16	read

Input Register (energy measurement values in 32/64-bit integer data format):

Register-Address	Protocol-Address	Name	Value range	Description	Data type	Access rights
32001 ... 32002	2000 ... 2001	L1_Vrms	0 ... $2^{32}-1$	RMS voltage phase L1 in mV	UINT32	read
32003 ... 32004	2002 ... 2003	L1_Irms	0 ... $2^{32}-1$	RMS current phase L1 in μ A	UINT32	read
32005 ... 32006	2004 ... 2005	L1_Vpeak	0 ... $2^{32}-1$	Voltage peak phase L1 in mV	UINT32	read
32007 ... 32008	2006 ... 2007	L1_Ipeak	0 ... $2^{32}-1$	Current peak phase L1 in μ A	UINT32	read
32009 ... 32010	2008 ... 2009	L1_PowerFactor	0 ... 10000	Power factor phase L1 = $ I_{\text{Active}}/I_{\text{Apparent}} * 10000$	UINT32	read
32011	2010	L1_Frequency	0 ... $2^{16}-1$	Frequency phase L1 in Hz/100	UINT16	read
32012 ... 32015	2011 ... 2014	L1_ActivePower	-2^{63} ... $2^{63}-1$	Active power phase L1 in μ W	INT64	read
32016 ... 32019	2015 ... 2018	L1_ReactivePower	-2^{63} ... $2^{63}-1$	Reactive power phase L1 in μ VA	INT64	read
32020 ... 32023	2019 ... 2022	L1_ApparentPower	0 ... $2^{64}-1$	Apparent power phase L1 in μ VA	UINT64	read
32024 ... 32027	2023 ... 2026	L1_consumedActiveEnergy	0 ... $2^{64}-1$	Active energy phase L1 (consumed) in μ Wh	UINT64	read
32028 ... 32031	2027 ... 2030	L1_deliveredActiveEnergy	0 ... $2^{64}-1$	Active energy phase L1 (delivered) in μ Wh	UINT64	read
32032 ... 32035	2031 ... 2034	L1_inductiveReactiveEnergy	0 ... $2^{64}-1$	Reactive energy phase L1 (inductive) in μ VAh	UINT64	read
32036 ... 32039	2035 ... 2038	L1_capacitiveReactiveEnergy	0 ... $2^{64}-1$	Reactive energy phase L1 (capacitive) in μ VAh	UINT64	read
32040 ... 32043	2039 ... 2042	L1_ApparentEnergy	0 ... $2^{64}-1$	Apparent energy phase L1 in μ VAh	UINT64	read
32044 ... 32045	2043 ... 2044	L2_Vrms	0 ... $2^{32}-1$	RMS voltage phase L2 in mV	UINT32	read
32046 ... 32047	2045 ... 2046	L2_Irms	0 ... $2^{32}-1$	RMS current phase L2 in μ A	UINT32	read
32048 ... 32049	2047 ... 2048	L2_Vpeak	0 ... $2^{32}-1$	Voltage peak phase L2 in mV	UINT32	read
32050 ... 32051	2049 ... 2050	L2_Ipeak	0 ... $2^{32}-1$	Current peak phase L2 in μ A	UINT32	read
32052 ... 32053	2051 ... 2052	L2_PowerFactor	0 ... 10000	Power factor phase L2 = $ I_{\text{Active}}/I_{\text{Apparent}} * 10000$	UINT32	read
32054	2053	L2_Frequency	0 ... $2^{16}-1$	Frequency phase L2 in Hz/100	UINT16	read
32055 ... 32058	2054 ... 2057	L2_ActivePower	-2^{63} ... $2^{63}-1$	Active power phase L2 in μ W	INT64	read
32059 ... 32062	2058 ... 2061	L2_ReactivePower	-2^{63} ... $2^{63}-1$	Reactive power phase L2 in μ VA	INT64	read
32063 ... 32066	2062 ... 2065	L2_ApparentPower	0 ... $2^{64}-1$	Apparent power phase L2 in μ VA	UINT64	read
32067 ... 32070	2066 ... 2069	L2_consumedActiveEnergy	0 ... $2^{64}-1$	Active energy phase L2 (consumed) in μ Wh	UINT64	read

Parameter Table

Input Register (energy measurement values in 32/64-bit integer data format):

Register-Adress	Protocol-Adress	Name	Value range	Description	Data type	Access rights
32071 ... 32074	2070 ... 2073	L2_deliveredActiveEnergy	0 ... $2^{64}-1$	Active energy phase L2 (delivered) in μWh	UINT64	read
32075 ... 32078	2074 ... 2077	L2_inductiveReactiveEnergy	0 ... $2^{64}-1$	Reactive energy phase L2 (inductive) in μVArh	UINT64	read
32079 ... 32082	2078 ... 2081	L2_capacitiveReactiveEnergy	0 ... $2^{64}-1$	Reactive energy phase L2 (capacitive) in μVArh	UINT64	read
32083 ... 32086	2082 ... 2085	L2_ApparentEnergy	0 ... $2^{64}-1$	Apparent energy phase L2 in μVAh	UINT64	read
32087 ... 32088	2086 ... 2087	L3_Vrms	0 ... $2^{32}-1$	RMS voltage phase L3 in mV	UINT32	read
32089 ... 32090	2088 ... 2089	L3_Irms	0 ... $2^{32}-1$	RMS current phase L3 in μA	UINT32	read
32091 ... 32092	2090 ... 2091	L3_Vpeak	0 ... $2^{32}-1$	Voltage peak phase L3 in mV	UINT32	read
32093 ... 32094	2092 ... 2093	L3_Ipeak	0 ... $2^{32}-1$	Current peak phase L3 in μA	UINT32	read
32095 ... 32096	2094 ... 2095	L3_PowerFactor	0 ... 10000	Power Factor phase L3 = $I_{\text{Active}}/P_{\text{Apparent}} \cdot 10000$	UINT32	read
32097	2096	L3_Frequency	0 ... $2^{16}-1$	Frequency phase L3 in Hz/100	UINT16	read
32098 ... 32101	2097 ... 2100	L3_ActivePower	-2^{63} ... $2^{63}-1$	Active power phase L3 in μW	INT64	read
32102 ... 32105	2101 ... 2104	L3_ReactivePower	-2^{63} ... $2^{63}-1$	Reactive power phase L3 in μVAr	INT64	read
32106 ... 32109	2105 ... 2108	L3_ApparentPower	0 ... $2^{64}-1$	Apparent power phase L3 in μVA	UINT64	read
32110 ... 32113	2109 ... 2112	L3_consumedActiveEnergy	0 ... $2^{64}-1$	Active energy phase L3 (consumed) in μWh	UINT64	read
32114 ... 32117	2113 ... 2116	L3_deliveredActiveEnergy	0 ... $2^{64}-1$	Active energy phase L3 (delivered) in μWh	UINT64	read
32118 ... 32121	2117 ... 2120	L3_inductiveReactiveEnergy	0 ... $2^{64}-1$	Reactive energy phase L3 (inductive) in μVArh	UINT64	read
32122 ... 32125	2121 ... 2124	L3_capacitiveReactiveEnergy	0 ... $2^{64}-1$	Reactive energy phase L3 (capacitive) in μVArh	UINT64	read
32126 ... 32129	2125 ... 2128	L3_ApparentEnergy	0 ... $2^{64}-1$	Apparent energy phase L3 in μVAh	UINT64	read
32130 ... 32133	2129 ... 2132	TotalActivePower	-2^{63} ... $2^{63}-1$	Total active power in μW	INT64	read
32134 ... 32137	2133 ... 2136	TotalReactivePower	-2^{63} ... $2^{63}-1$	Total reactive power in μVAr	INT64	read
32138 ... 32141	2137 ... 2140	TotalApparentPower	0 ... $2^{64}-1$	Total apparent power in μVA	UINT64	read
32142 ... 32145	2141 ... 2144	ConsumedTotalActiveEnergy	0 ... $2^{64}-1$	Total active energy (consumed) in μWh	UINT64	read
32146 ... 32149	2145 ... 2148	DeliveredTotalActiveEnergy	0 ... $2^{64}-1$	Total active energy (delivered) in μWh	UINT64	read
32150 ... 32153	2149 ... 2152	InductiveTotalReactiveEnergy	0 ... $2^{64}-1$	Total reactive energy (inductive) in μVArh	UINT64	read
32154 ... 32157	2153 ... 2156	CapacitiveTotalReactiveEnergy	0 ... $2^{64}-1$	Total reactive energy (capacitive) in μVArh	UINT64	read
32158 ... 32161	2157 ... 2160	TotalApparentEnergy	0 ... $2^{64}-1$	Total apparent energy in μVAh	UINT64	read

Parameter Table

Input Register (energy measurement values in floating point data format IEEE 754):

Register-Address	Protocol-Address	Name	Value range	Description	Data type	Access rights
32162 ... 32163	2161 ... 2162	L1_Vrms	0 ... 300.0	RMS Voltage Phase L1 in V	FLOAT32	read
32164 ... 32165	2163 ... 2164	L1_Irms	0 ... 4200.0	RMS current Phase L1 in A	FLOAT32	read
32166 ... 32167	2165 ... 2166	L1_Vpeak	0 ... 424.0	Voltage peak Phase L1 in V	FLOAT32	read
32168 ... 32169	2167 ... 2168	L1_Ipeak	0 ... 4200.0	Current peak Phase L1 in A	FLOAT32	read
32170 ... 32171	2169 ... 2170	L1_PowerFactor	0 ... 1.0000	Power Factor Phase L1 = $I_{\text{Pactive}}/P_{\text{apparent}} \cdot 10000$	FLOAT32	read
32172 ... 32173	2171 ... 2172	L1_Frequency	45.00 ... 65.00	Frequency Phase L1 in Hz	FLOAT32	read
32174 ... 32175	2173 ... 2174	L1_ActivePower	$-9.2 \cdot 10^{12}$... $9.2 \cdot 10^{12}$	Active power Phase L1 in W	FLOAT32	read
32176 ... 32177	2175 ... 2176	L1_ReactivePower	$-9.2 \cdot 10^{12}$... $9.2 \cdot 10^{12}$	Reactice power Phase L1 in VAR	FLOAT32	read
32178 ... 32179	2177 ... 2178	L1_ApparentPower	0 ... $1.8 \cdot 10^{13}$	Apparent power Phase L1 in VA	FLOAT32	read
32180 ... 32181	2179 ... 2180	L1_consumedActiveEnergy	0 ... $3.4 \cdot 10^{38}$	Active energy Phase L1 (consumed) in Wh	FLOAT32	read
32182 ... 32183	2181 ... 2282	L1_deliveredActiveEnergy	0 ... $3.4 \cdot 10^{38}$	Active energy Phase L1 (delivered) in Wh	FLOAT32	read
32184 ... 32185	2183 ... 2184	L1_inductiveReactiveEnergy	0 ... $3.4 \cdot 10^{38}$	Reactive energy Phase L1 (inductive) in VARh	FLOAT32	read
32186 ... 32187	2185 ... 2186	L1_capacitiveReactiveEnergy	0 ... $3.4 \cdot 10^{38}$	Reactive energy Phase L1 (capacitive) in VARh	FLOAT32	read
32188 ... 32189	2187 ... 2188	L1_ApparentEnergy	0 ... $3.4 \cdot 10^{38}$	Apparent energy Phase L1 in VAh	FLOAT32	read
32190 ... 32191	2189 ... 2190	L2_Vrms	0 ... 300.0	RMS Voltage Phase L2 in V	FLOAT32	read
32192 ... 32193	2191 ... 2192	L2_Irms	0 ... 4200.0	RMS current Phase L2 in A	FLOAT32	read
32194 ... 32195	2193 ... 2194	L2_Vpeak	0 ... 424.0	Voltage peak Phase L2 in V	FLOAT32	read
32196 ... 32197	2195 ... 2196	L2_Ipeak	0 ... 4200.0	Current peak Phase L2 in A	FLOAT32	read
32198 ... 32199	2197 ... 2198	L2_PowerFactor	0 ... 1.0000	Power Factor Phase L2 = $I_{\text{Pactive}}/P_{\text{apparent}} \cdot 10000$	FLOAT32	read
32200 ... 32201	2199 ... 2200	L2_Frequency	45.00 ... 65.00	Frequency Phase L2 in Hz	FLOAT32	read
32202 ... 32203	2201 ... 2202	L2_ActivePower	$-9.2 \cdot 10^{12}$... $9.2 \cdot 10^{12}$	Active power Phase L2 in W	FLOAT32	read
32204 ... 32205	2203 ... 2204	L2_ReactivePower	$-9.2 \cdot 10^{12}$... $9.2 \cdot 10^{12}$	Reactice power Phase L2 in VAR	FLOAT32	read
32206 ... 32207	2205 ... 2206	L2_ApparentPower	0 ... $1.8 \cdot 10^{13}$	Apparent power Phase L2 in VA	FLOAT32	read
32208 ... 32209	2207 ... 2208	L2_consumedActiveEnergy	0 ... $3.4 \cdot 10^{38}$	Active energy Phase L2 (consumed) in Wh	FLOAT32	read
32210 ... 32211	2209 ... 2210	L2_deliveredActiveEnergy	0 ... $3.4 \cdot 10^{38}$	Active energy Phase L2 (delivered) in Wh	FLOAT32	read
32212 ... 32213	2211 ... 2212	L2_inductiveReactiveEnergy	0 ... $3.4 \cdot 10^{38}$	Reactive energy Phase L2 (inductive) in VARh	FLOAT32	read
32214 ... 32215	2213 ... 2214	L2_capacitiveReactiveEnergy	0 ... $3.4 \cdot 10^{38}$	Reactive energy Phase L2 (capacitive) in VARh	FLOAT32	read
32216 ... 32217	2215 ... 2216	L2_ApparentEnergy	0 ... $3.4 \cdot 10^{38}$	Apparent energy Phase L2 in VAh	FLOAT32	read
32218 ... 32219	2217 ... 2218	L3_Vrms	0 ... 300.0	RMS Voltage Phase L3 in V	FLOAT32	read
32220 ... 32221	2219 ... 2220	L3_Irms	0 ... 4200.0	RMS current Phase L3 in A	FLOAT32	read

Parameter Table

Input Register (energy measurement values in floating point data format IEEE 754):

Register-Adress	Protocol-Adress	Name	Value range	Description	Data type	Access rights
32222 ... 32223	2221 ... 2222	L3_Vpeak	0 ... 424.0	Voltage peak Phase L3 in V	FLOAT32	read
32224 ... 32225	2223 ... 2224	L3_Ipeak	0 ... 4200.0	Current peak Phase L3 in A	FLOAT32	read
32226 ... 32227	2225 ... 2226	L3_PowerFactor	0 ... 1.0000	Power Factor Phase L3 = $I_{\text{Pactive}}/I_{\text{Papparent}} \cdot 10000$	FLOAT32	read
32228 ... 32229	2227 ... 2228	L3_Frequency	45.00 ... 65.00	Frequency Phase L3 in Hz	FLOAT32	read
32230 ... 32231	2229 ... 2230	L3_ActivePower	$-9.2 \cdot 10^{12}$... $9.2 \cdot 10^{12}$	Active power Phase L3 in W	FLOAT32	read
32232 ... 32233	2231 ... 2232	L3_ReactivePower	$-9.2 \cdot 10^{12}$... $9.2 \cdot 10^{12}$	Reactice power Phase L3 in VAR	FLOAT32	read
32234 ... 32235	2233 ... 2234	L3_ApparentPower	0 ... $1.8 \cdot 10^{13}$	Apparent power Phase L3 in VA	FLOAT32	read
32236 ... 32237	2235 ... 2236	L3_consumedActiveEnergy	0 ... $3.4 \cdot 10^{38}$	Active energy Phase L3 (consumed) in Wh	FLOAT32	read
32238 ... 32239	2237 ... 2238	L3_deliveredActiveEnergy	0 ... $3.4 \cdot 10^{38}$	Active energy Phase L3 (delivered) in Wh	FLOAT32	read
32240 ... 32241	2239 ... 2240	L3_inductiveReactiveEnergy	0 ... $3.4 \cdot 10^{38}$	Reactive energy Phase L3 (inductive) in VARh	FLOAT32	read
32242 ... 32243	2241 ... 2242	L3_capacitiveReactiveEnergy	0 ... $3.4 \cdot 10^{38}$	Reactive energy Phase L3 (capacitive) in VARh	FLOAT32	read
32244 ... 32245	2243 ... 2244	L3_ApparentEnergy	0 ... $3.4 \cdot 10^{38}$	Apparent energy Phase L3 in VAh	FLOAT32	read
32246 ... 32247	2245 ... 2246	TotalActivePower	$-9.2 \cdot 10^{12}$... $9.2 \cdot 10^{12}$	Total active power in W	FLOAT32	read
32248 ... 32249	2247 ... 2248	TotalReactivePower	$-9.2 \cdot 10^{12}$... $9.2 \cdot 10^{12}$	Total reactive power in VAR	FLOAT32	read
32250 ... 32251	2249 ... 2250	TotalApparentPower	0 ... $1.8 \cdot 10^{13}$	Total apparent power in VA	FLOAT32	read
32252 ... 32253	2251 ... 2252	ConsumedTotalActiveEnergy	0 ... $3.4 \cdot 10^{38}$	Total active energy (consumed) in Wh	FLOAT32	read
32254 ... 32255	2253 ... 2254	DeliveredTotalActiveEnergy	0 ... $3.4 \cdot 10^{38}$	Total active energy (delivered) in Wh	FLOAT32	read
32256 ... 32257	2255 ... 2256	InductiveTotalReactiveEnergy	0 ... $3.4 \cdot 10^{38}$	Total reactive energy (inductive) in VARh	FLOAT32	read
32258 ... 32259	2257 ... 2258	CapacitiveTotalReactiveEnergy	0 ... $3.4 \cdot 10^{38}$	Total reactive energy (capacitive) in VARh	FLOAT32	read
32260 ... 32261	2259 ... 2260	TotalApparentEnergy	0 ... $3.4 \cdot 10^{38}$	Total apparent energy in VAh	FLOAT32	read

