

KVE 3-6-10

VERTICAL AXIS MULTISTAGE CENTRIFUGAL PUMPS WITH MCE/P INVERTER



TECHNICAL DATA

Operating range:

from 1,8 to 13,5 m³/h, with head up to 158 metres.

Liquid temperature range:

from 0 °C to 35 °C for domestic use,
from -15 °C to 80 °C for other uses.

Pumped liquid: clean, free of solids and abrasives, non-viscous, non-aggressive, non-crystallised and chemically neutral.

Maximum ambient temperature: + 40 °C.

Maximum operating pressure: 18 bar (1800 kPa).

Standard voltage:

single-phase 1x230 V / 50/60 Hz.

three-phase 3x400 V / 50 Hz.

Protection class: IP 55

Insulation class: F.

Installation: fixed, vertical position.

APPLICATIONS

Vertical multistage centrifugal pump suitable for medium to large user water systems. Recommended for pressurisation units, boiler supply, hot water and cooling water circulation, fire fighting and washing systems, drinking water supply and filling of pressure vessels, sprinkler and watering systems and water purification systems.

ADVANTAGES OF USE

Operating pressure stability – **Excellent energy savings** (up to 60 %) – Reduced hammering effects – Reduced space requirements – Less maintenance – Reduced pump wear – Less power factor correction required – Less water consumption – Integrated protections.

CONSTRUCTION FEATURES OF THE PUMP

Cast iron delivery and suction bodies treated against corrosion. Impellers, diffuser bodies and diffusers in technopolymer. AISI 304 stainless steel pump liner and adjustment rings. Pump shaft in AISI 416 stainless steel. AISI 316 stainless steel sliding bushing.

Bronze sliding bushing guide, self-lubricated using the pumped liquid itself. Carbon/ceramic mechanical seal. Rigid coupling motor shaft to pump shaft connection. Threaded counter-flanges supplied as standard.

CONSTRUCTION FEATURES OF THE MOTOR

Shaft with rotor running on permanently lubricated ball bearings, oversized to ensure low noise and durability. Construction according to CEI 2-3. Controlled by MCE inverter. Insulation class: F. Standard single-phase voltage: 1x230 V / 50-60 Hz. Special version on request: three-phase 3x400 V / 50 Hz or three-phase 3x460 V / 60 Hz. Standard three-phase voltage: 3x400 V / 50 Hz. Special version on request: 3x460 V / 60 Hz.

MATERIALS

N.	PARTS*	MATERIALS
4	IMPELLER	TECHNOPOLYMER B
6	DIFFUSER	TECHNOPOLYMER B
7A	PUMP SHAFT	AISI 416 STAINLESS STEEL X12 CrS 13 UNI 6900/71
16	MECHANICAL SEAL	CARBON / CERAMIC
28	OR RING	EPDM RUBBER
69	LINER	AISI 304 STAINLESS STEEL X5 CrNi 1810 UNI 6900/71
95	OR RING	EPDM RUBBER
96	SUCTION BODY	CAST IRON 200 UNI ISO 185
97	DELIVERY BODY	CAST IRON 200 UNI ISO 185
98	DIFFUSER BODY	TECHNOPOLYMER B

* In contact with the liquid.

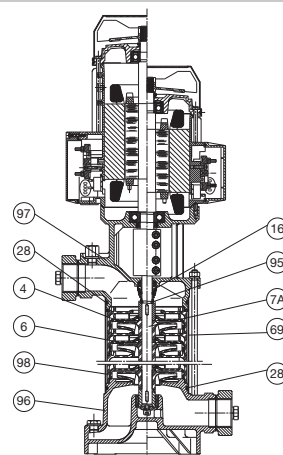

ORIENTATION OF THE SUCTION AND DELIVERY CONNECTORS:

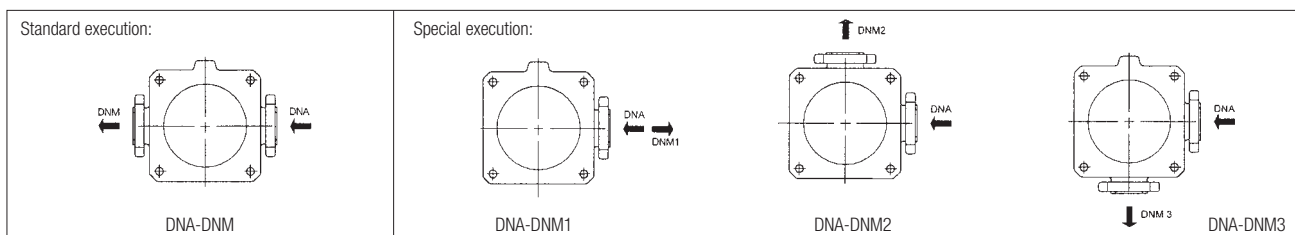

MCE/P INVERTER



CONSTRUCTION FEATURES OF THE ELECTRONICS: MCE/P INVERTER

The inverter continuously adjusts the rotation speed of the electric pump, keeping the pressure constant, even when the flow rate varies. The other electric pumps, also with variable speed, are activated in cascade after the first one has reached maximum speed. Through modulation, they compensate the pressure fluctuations of the system.

For every operating cycle, it is possible to switch the restart to a different pump, therefore ensuring even use of all electric pumps.

It is possible to set operation times for each individual pump, switching to another pump after such set times.

The "SP" pressure can be adjusted by the user using the "+" and "-" keys found on the MCE/P (as a rule, all the pumps are set to the same pressure value). With the new MCE/P, it is sufficient to set the data on one of the devices, and it will be automatically propagated to the other pumps of the system.

MODES OF OPERATION

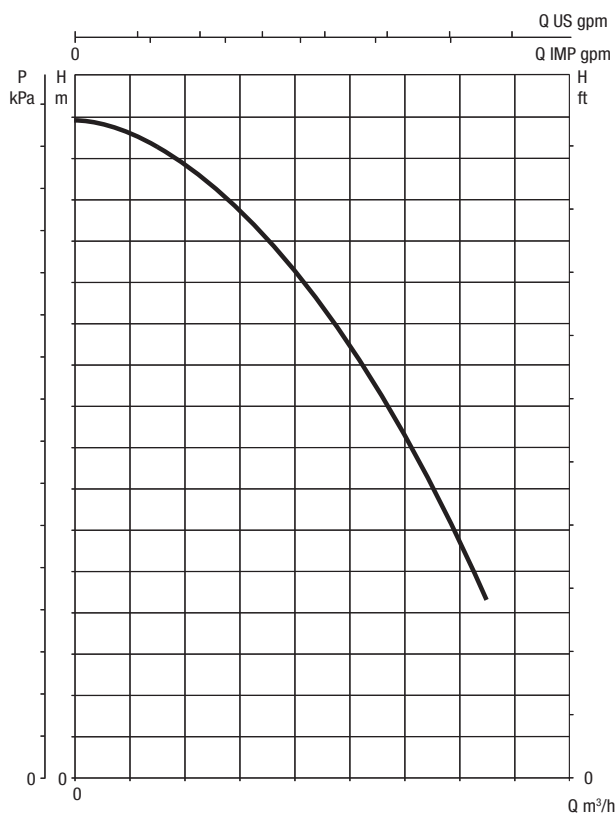

PERFORMANCE CURVES WITHOUT INVERTER

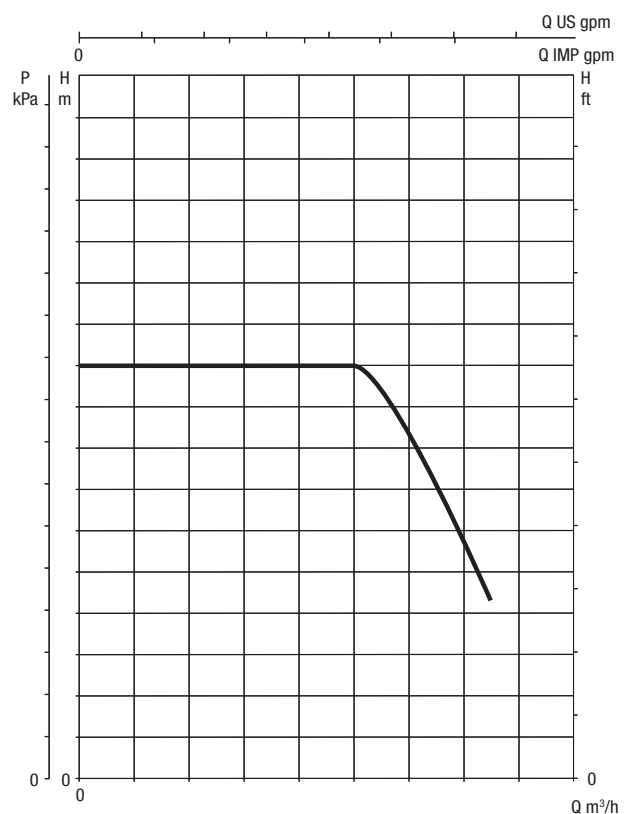

PERFORMANCE CURVES WITH INVERTER

The inverter is capable of maintaining a constant pressure even when the flow rate varies.

The operating pressure can be adjusted by the user.

A good pressure set-point is between 1/3 and 2/3 of the maximum head of the electric pump. In this way, high efficiency of the pump is maintained, together with maximum saving.

In addition, the MCE/P does not block the pump if the pressure is not reached, but the flow is present. This prevents service interruptions in case of high flows.

For more information refer to the technical appendix.

SELECTION TABLE - KVE 3

MODEL	P2 NOMINAL		Q=m ³ /h	0	1,8	3,6	5,4	7,2
	kW	HP	Q=l/min	0	30	60	90	120
KVE 3/10 M MCE15/P	1,1	1,5	H (m)	88	77	63,5	45,7	21
KVE 3/12 M MCE15/P	1,5	2		105,6	92,4	76,2	54,8	25,2
KVE 3/15 M MCE22/P	1,85	2,5		132	115,5	95,3	68,6	31,5
KVE 3/18 T MCE30/P	2,2	3		158,4	138,6	114,3	82,3	37,8

SELECTION TABLE - KVE 6

MODEL	P2 NOMINAL		Q=m ³ /h	0	1,8	3,6	5,4	7,2	8,4	10,2	12
	kW	HP	Q=l/min	0	30	60	90	120	140	170	200
KVE 6/7 M MCE11/P	1,1	1,5	H (m)	62,3	57,8	51,5	42,5	29,5	18,6		
KVE 6/9 M MCE15/P	1,5	2		80,1	74,3	66,2	54,6	38	23,9	16,4	12,0
KVE 6/11 M MCE15/P	1,84	2,5		97,9	90,8	81	66,8	46,4	29,2	24,2	18,0
KVE 6/15 T MCE30/P	2,2	3		133,5	123,8	110,4	91,1	63,3	39,8	34,0	26,3

SELECTION TABLE - KVE 10

MODEL	P2 NOMINAL		Q=m ³ /h	0	1,8	3,6	5,4	7,2	8,4	10,2	12	13,8
	kW	HP	Q=l/min	0	30	60	90	120	140	170	200	230
KVE 10/4 M MCE11/P	1,1	1,5	H (m)	38,2	37,4	36,2	34,4	32	29,7	25,5	20	12,6
KVE 10/5 M MCE15/P	1,5	2		47,8	46,8	45,2	43	40	37,2	31,9	25	15,8
KVE 10/6 M MCE22/P	1,84	2,5		57,3	56,1	54,2	51,6	48	44,6	38,2	30	18,9
KVE 10/8 T MCE30/P	2,2	3		76,4	74,8	72,3	68,8	64	59,4	51	40	25,2

KVE 3 - VERTICAL AXIS MULTISTAGE CENTRIFUGAL PUMPS WITH MCE/P INVERTER FOR PRESSURISATION SYSTEMS

Pumped liquid temperature range: from 0 °C to +35 °C for domestic use - from -15 °C to +80 °C for the other uses.

Maximum ambient temperature: +40 °C

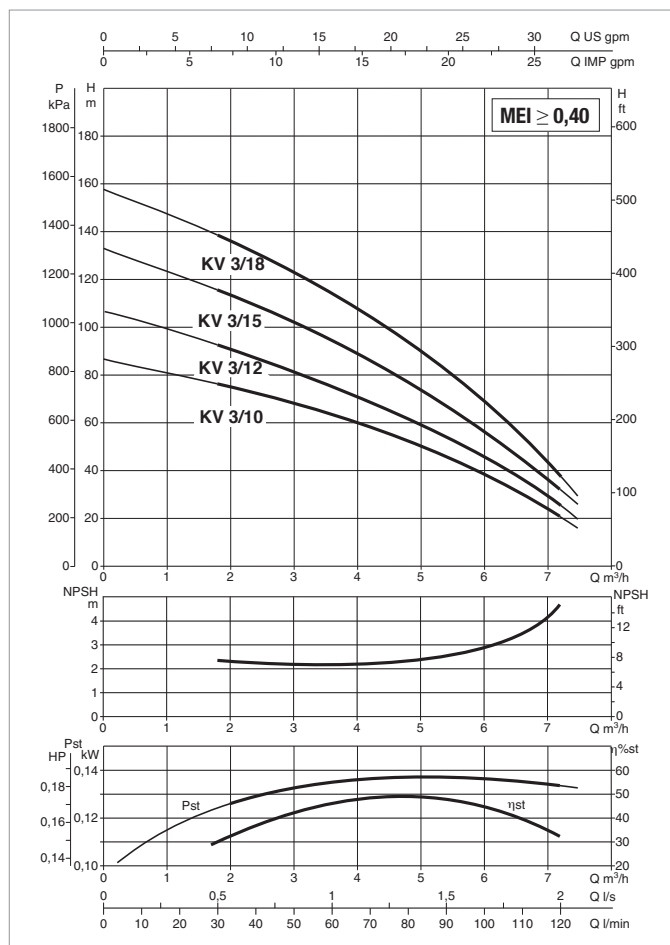
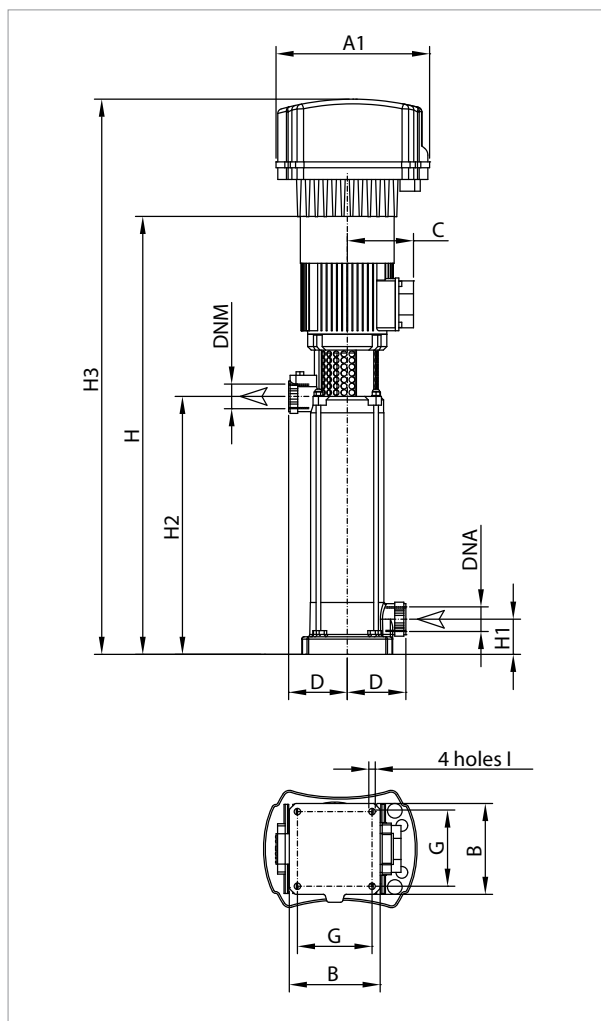

See hydraulic efficiency details on page 241.

The performance curves are based on kinematic viscosity values = 1 mm²/s and density equal to 1000 kg/m³. Curve tolerance according to ISO 9906.

MODEL	POWER INPUT 50 Hz	P2 NOMINAL		In A	r.p.m.
		kW	HP		
KVE 3/10 M MCE15/P	1 x 230 V	1,1	1,5	13,5	2890
KVE 3/12 M MCE15/P	1 x 230 V	1,5	2	15,4	2851
KVE 3/15 M MCE22/P	1 x 230 V	1,85	2,5	18,2	2844
KVE 3/18 T MCE30/P	3 x 400 V	2,2	3	7,06	2854

MODEL	A1	B	C	D	G	I	H	H1	H2	H3	DNA GAS	DNM GAS	PACKING DIMENSIONS			VOLUME m ³	WEIGHT kg
													L/A	L/B	H		
KVE 3/10 M MCE15/P	262	155	140	100	127	11	779	60	472	979	1,¼"	1¼"	1350	255	310	0,107	30,7
KVE 3/12 M MCE15/P	262	155	160	100	127	11	843	60	536	1043	1,¼"	1¼"	1350	255	310	0,107	32,4
KVE 3/15 M MCE22/P	262	155	160	100	127	11	1013	60	632	1213	1,¼"	1¼"	1350	255	310	0,107	36,3
KVE 3/18 T MCE30/P	262	155	160	100	127	11	1109	60	728	1304	1,¼"	1¼"	1350	255	310	0,107	40,2

KVE 6 - VERTICAL AXIS MULTISTAGE CENTRIFUGAL PUMPS WITH MCE/P INVERTER FOR PRESSURIZATION SYSTEMS

Pumped liquid temperature range: from 0 °C to +35 °C for domestic use - from -15 °C to +80 °C for the other uses.

Maximum ambient temperature: +40 °C

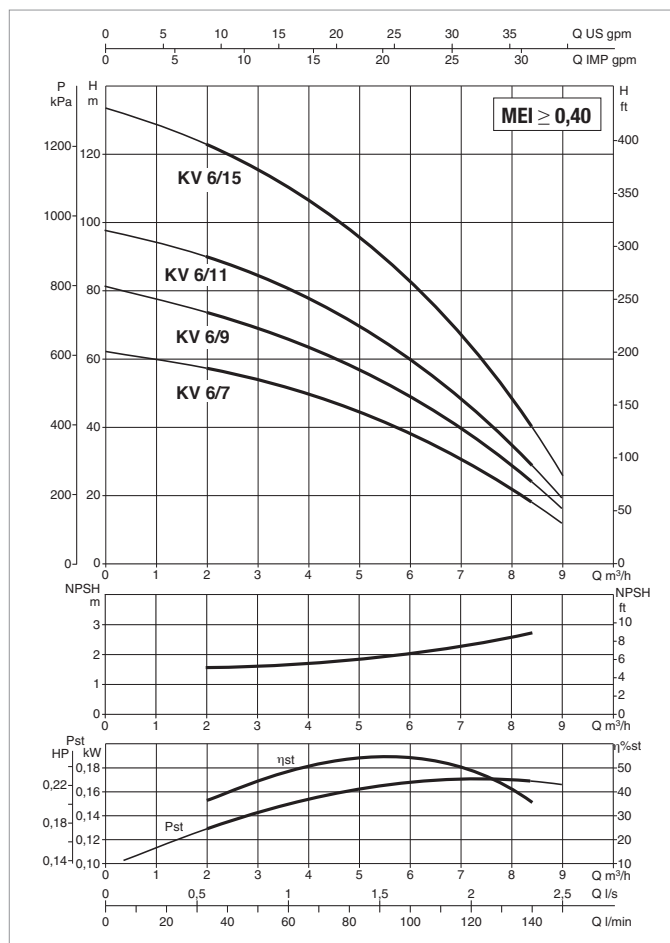
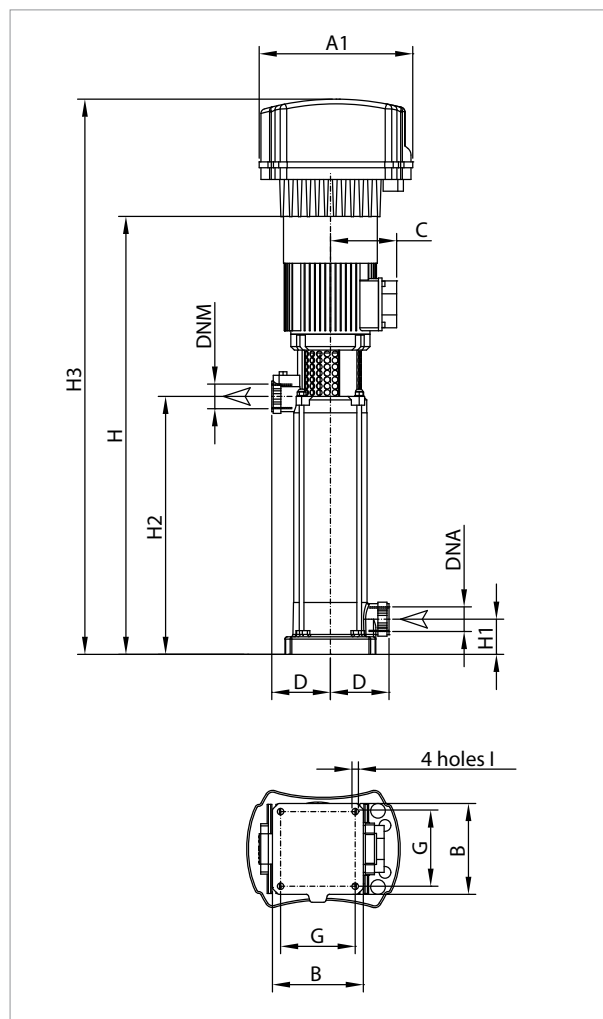

See hydraulic efficiency details on page 241.

The performance curves are based on kinematic viscosity values = 1 mm²/s and density equal to 1000 kg/m³. Curve tolerance according to ISO 9906.

MODEL	POWER INPUT 50 Hz	P2 NOMINAL		In A	r.p.m.
		kW	HP		
KVE 6/7 M MCE11/P	1 x 230 V	1,1	1,5	12,7	2890
KVE 6/9 M MCE15/P	1 x 230 V	1,5	2	15,5	2856
KVE 6/11 M MCE15/P	1 x 230 V	1,84	2,5	17,8	2825
KVE 6/15 T MCE30/P	3 x 400 V	2,2	3	7,41	2832

MODEL	A1	B	C	D	G	I	H	H1	H2	H3	DNA GAS	DNM GAS	PACKING DIMENSIONS			VOLUME m ³	WEIGHT kg
													L/A	L/B	H		
KVE 6/7 M MCE11/P	262	155	140	100	127	11	683	60	376	883	1,¼"	1¼"	1350	255	310	0,107	29,6
KVE 6/9 M MCE15/P	262	155	160	100	127	11	747	60	440	947	1,¼"	1¼"	1350	255	310	0,107	31,2
KVE 6/11 M MCE15/P	262	155	160	100	127	11	885	60	504	1085	1,¼"	1¼"	1350	255	310	0,107	32,1
KVE 6/15 T MCE30/P	262	155	160	100	127	11	1013	60	632	1213	1,¼"	1¼"	1350	255	310	0,107	38,9

KVE 10 - VERTICAL AXIS MULTISTAGE CENTRIFUGAL PUMPS WITH MCE/P INVERTER FOR PRESSURISATION SYSTEMS

Pumped liquid temperature range: from 0 °C to +35 °C for domestic use - from -15 °C to +80 °C for the other uses.

Maximum ambient temperature: +40 °C

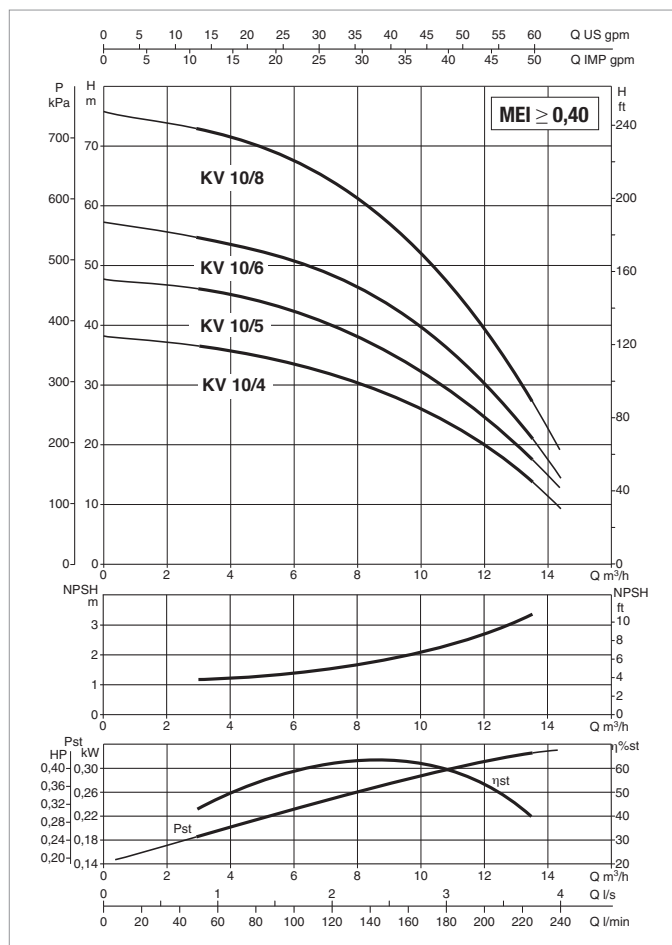
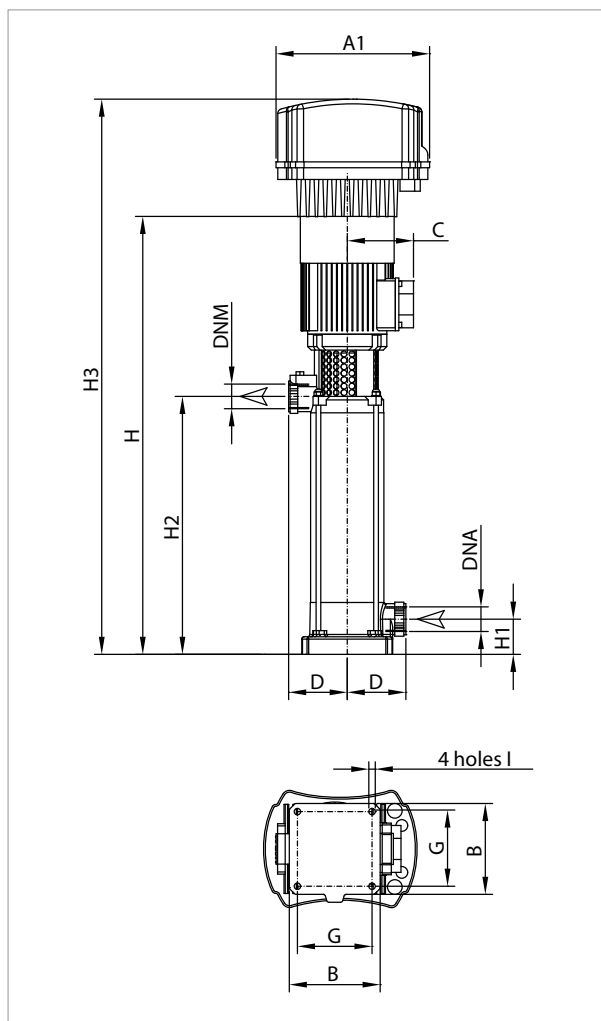

See hydraulic efficiency details on page 241.

The performance curves are based on kinematic viscosity values = 1 mm²/s and density equal to 1000 kg/m³. Curve tolerance according to ISO 9906.

MODEL	POWER INPUT 50 Hz	P2 NOMINAL		In A	r.p.m.
		kW	HP		
KVE 10/4 M MCE11/P	1 x 230 V	1,1	1,5	16,3	2853
KVE 10/5 M MCE15/P	1 x 230 V	1,5	2	17,3	2827
KVE 10/6 M MCE22/P	1 x 230 V	1,84	2,5	20,2	2813
KVE 10/8 T MCE30/P	3 x 400 V	2,2	3	8,01	2810

MODEL	A1	B	C	D	G	I	H	H1	H2	H3	DNA GAS	DNM GAS	PACKING DIMENSIONS			VOLUME m³	WEIGHT kg
													L/A	L/B	H		
KVE 10/4 M MCE11/P	262	155	140	100	127	11	587	60	280	787	1,¼"	1¼"	1350	255	310	0,107	27,5
KVE 10/5 M MCE15/P	262	155	160	100	127	11	619	60	312	819	1,¼"	1¼"	1350	255	310	0,107	29
KVE 10/6 M MCE22/P	262	155	160	100	127	11	725	60	344	925	1,¼"	1¼"	1350	255	310	0,107	32,3
KVE 10/8 T MCE30/P	262	155	160	100	127	11	789	60	408	989	1,¼"	1¼"	1350	255	310	0,107	34,5