



# ENAPART



93 S Railroad Avenue Unit C  
Bergenfield NJ 07621 USA  
[www.enapart.com](http://www.enapart.com)  
[sales@enapart.com](mailto:sales@enapart.com)



Via del Canneto 35,  
Borgosatollo, Brescia - Italia  
[www.enapart.it](http://www.enapart.it)  
[vendite@enapart.it](mailto:vendite@enapart.it)



Barbaros Mah. Ihlamur Bul. Aĝaoĝlu  
My Newwork No:3/15 Ataşehir / İstanbul  
[www.enapart.net](http://www.enapart.net)  
[satis@enapart.net](mailto:satis@enapart.net)



PRIVADA 10 B SUR #3908 COL.  
ANZUREZ, C.P. 72530, PUEBLA, PUE  
[www.enapart.com.mx](http://www.enapart.com.mx)  
[sales@enapart.com.mx](mailto:sales@enapart.com.mx)



Friedrich-Ebert-Anlage 36, 60325  
Frankfurt am Main, Germany  
[www.enapart.de](http://www.enapart.de)  
[anfrage@enapart.de](mailto:anfrage@enapart.de)



4 boulevard Carnot, 95400  
villiers-le-bel, Paris, France  
[www.enapart.fr](http://www.enapart.fr)  
[sales@enapart.fr](mailto:sales@enapart.fr)



65049, ОДЕСА, ВУЛИЦЯ ІВАНА  
ФРАНКА, БУДИНОК 55, ПОВЕРХ 3  
[www.enapart.com.ua](http://www.enapart.com.ua)  
[sales@enapart.com.ua](mailto:sales@enapart.com.ua)



MUNICIPIUL BUCUREȘTI, SECTOR 3,  
B-DUL BASARABIA, NR.250, CORP P+5  
[www.enapart.ro](http://www.enapart.ro)  
[sales@enapart.ro](mailto:sales@enapart.ro)



〒584-0023 大阪府富田林市若松町  
東2丁目2番16号  
[www.enapart.co.jp](http://www.enapart.co.jp)  
[sales@enapart.co.jp](mailto:sales@enapart.co.jp)



PLAZA NUESTRA SEÑORA DE LAS  
NIEVES 12 ,LOCAL ,50012,ZARAGOZA  
[www.enapart.es](http://www.enapart.es)  
[ventas@enapart.es](mailto:ventas@enapart.es)



Складова база „Онгъл“, Склад А2, п.к.  
4006, гр. Пловдив, България  
[www.enapart.bg](http://www.enapart.bg)  
[sales@enapart.bg](mailto:sales@enapart.bg)



3 Austin Mews, High Street, Hemel  
Hempstead, HP1 3AF , United Kingdom  
[www.enapart.co.uk](http://www.enapart.co.uk)  
[sales@enapart.co.uk](mailto:sales@enapart.co.uk)

## Art. "C3" - THREE WAY SHUTTER VALVE FOR VACUUM-VACUUM BREAKER



### DESCRIZIONE

Intercepting valve purposely conceived to suddenly break the vacuum in the system (i.e. release of suction cups).

Pneumatic actuator with reciprocating piston movement.

Flat shutter closing with double seal in NBR.

Three-way and 2-position function (3/2).

Perfect airtight.

### SECTORS OF USE

It is generally used for vacuum (wrapping machines, material handling by suction caps).

Connections with inner GAS ISO 228 thread female-female.

Control air 1/8" GAS connections.

### ALLOWABLE TEMPERATURES

Operating temperature: from -20°C to +100°C

**ACTUATOR PILOT PRESSURE:** Max 8 bar.

### VERSIONS AND SIZES

DA: 1/2" - 1"1/4 - 2" - 3"

**ANODIZING TREATMENT ON OUTSIDE DETAILS**

**MADE IN ALUMINIUM**

### SLOTTED HOLE OPENING FOR VACUUM OUTLET

G	1/2"	1"1/4	2"	3"
Cm <sup>2</sup>	1,13	8,6	12,6	19,5

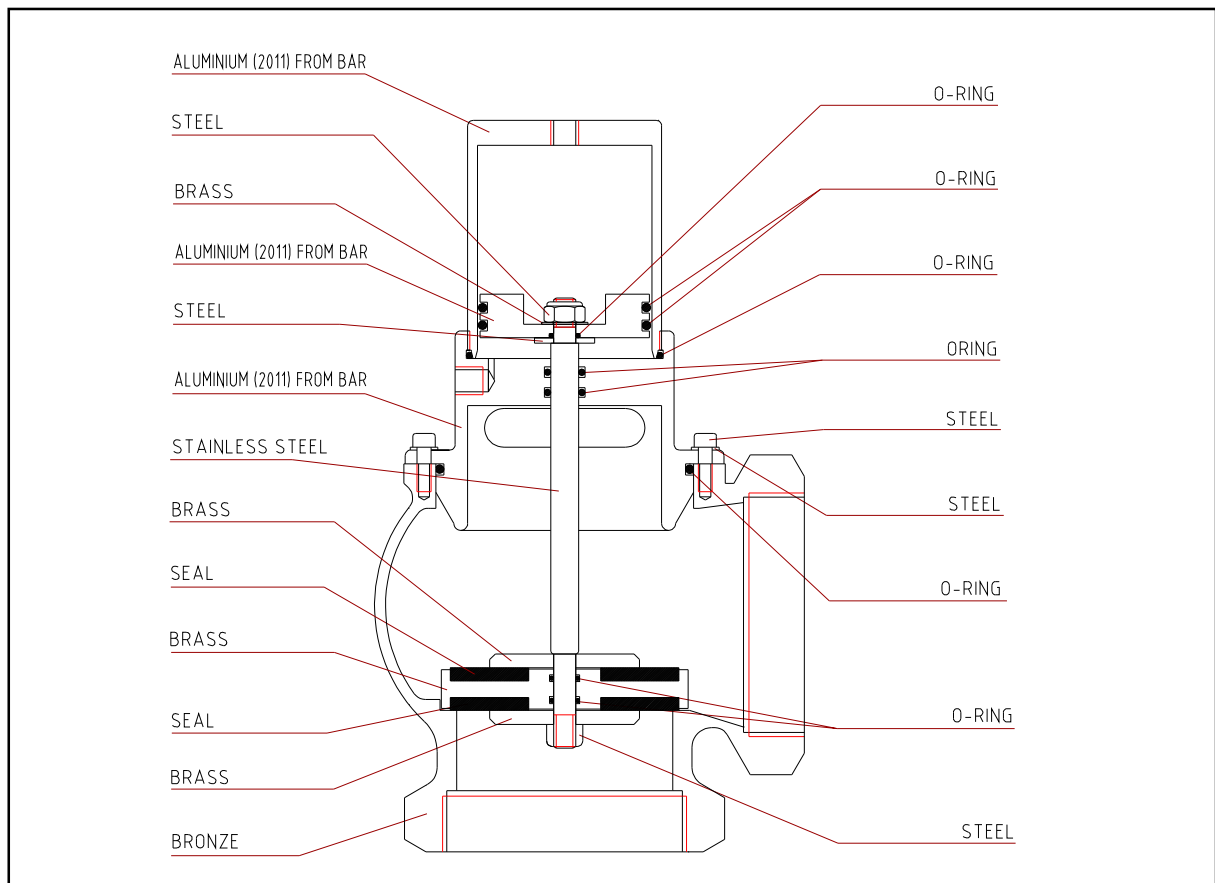

Art. "C3"

**OPERATION**

When the valve is open (drawing 1) the vacuum can be created and kept inside the unit, the arrow indicates the passage from the unit to the suction pump.

When the valve is closed (drawing 2), vacuum can be exhausted through the holes of the central body, the arrows indicate the air passage from outside towards the unit.

**ASSEMBLY**

The direction of vacuum flow must be as shown in drawing 1, i.e. OPPOSITE to the arrow printed into the valve body.

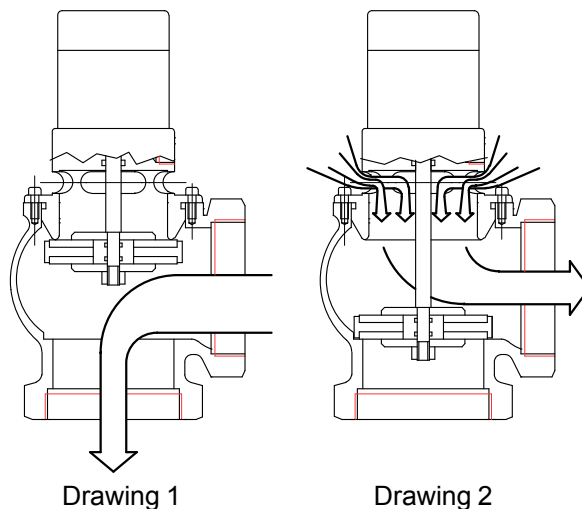

Drawing 1

Drawing 2

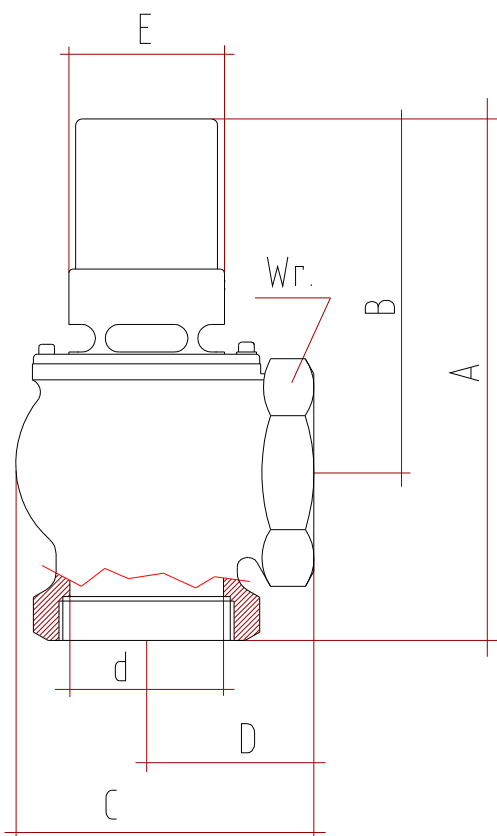

**OVERALL DIMENSIONS**

DN	G	A	B	C	D	E	d	Wrench	Weight
mm.		mm.	mm.	mm.	mm.	mm.	mm.	mm.	gr.
15	1/2"	121	89	52	32	50	15	27	500
32	1"1/4	173	124	82	49	65	32	50	1350
50	2"	195	134	110	61	65	50	70	2350
80	3"	264	179	155	85	79	78	100	4920