



ENAPART



93 S Railroad Avenue Unit C
Bergenfield NJ 07621 USA
www.enapart.com
sales@enapart.com



Via del Canneto 35,
Borgosatollo, Brescia - Italia
www.enapart.it
vendite@enapart.it



Barbaros Mah. Ihlamur Bul. Aĝaoĝlu
My Newwork No:3/15 Ataşehir / İstanbul
www.enapart.net
satis@enapart.net



PRIVADA 10 B SUR #3908 COL.
ANZUREZ, C.P. 72530, PUEBLA, PUE
www.enapart.com.mx
sales@enapart.com.mx



Friedrich-Ebert-Anlage 36, 60325
Frankfurt am Main, Germany
www.enapart.de
anfrage@enapart.de



4 boulevard Carnot, 95400
villiers-le-bel, Paris, France
www.enapart.fr
sales@enapart.fr



65049, ОДЕСА, ВУЛИЦЯ ІВАНА
ФРАНКА, БУДИНОК 55, ПОВЕРХ 3
www.enapart.com.ua
sales@enapart.com.ua



MUNICIPIUL BUCUREȘTI, SECTOR 3,
B-DUL BASARABIA, NR.250, CORP P+5
www.enapart.ro
sales@enapart.ro



〒584-0023 大阪府富田林市若松町
東2丁目2番16号
www.enapart.co.jp
sales@enapart.co.jp



PLAZA NUESTRA SEÑORA DE LAS
NIEVES 12 ,LOCAL ,50012,ZARAGOZA
www.enapart.es
ventas@enapart.es



Складова база „Онгъл“, Склад А2, п.к.
4006, гр. Пловдив, България
www.enapart.bg
sales@enapart.bg



3 Austin Mews, High Street, Hemel
Hempstead, HP1 3AF , United Kingdom
www.enapart.co.uk
sales@enapart.co.uk

Art. "A" - GATE VALVE



DESCRIPTION

Metal sealing with free disks (male/female disk) in the wedge of the gate.
Practically no maintenance is required for the special closing system (metal to metal), but a perfect airtight is not assured.

Pneumatic actuator, with reciprocating movement, is equipped with manual emergency knob.

The pneumatic gate valve can intercept liquid fluids and gases without solid suspensions (keep into account the closing system).

Standard: Connections with inner GAS ISO 228 female-female.

On request: NPT connections.

Control air 1/8" GAS connections.

OPERATING TEMPERATURE: from -20°C to +80°C.

ACTUATOR PILOT PRESSURE: Max 8 bar.

VERSIONS AND SIZES

GAS threaded connection

DA: 3/4" - 1" - 1"1/4 - 1"1/2 - 2" - 2"1/2 - 3" - 4"

SANC: 3/4" - 1" - 1"1/4 - 1"1/2 - 2" - 2"1/2 - 3"

SANO: 3/4" - 1" - 1"1/4 - 1"1/2 - 2"

NPT connection

DA: 3/4" - 1" - 1"1/4 - 1"1/2 - 2" - 3"

SANC: 3/4" - 1" - 1"1/4 - 1"1/2 - 2" - 3"

SANO: 3/4" - 1" - 1"1/4 - 1"1/2 - 2"

ANODIZING TREATMENT ON OUTSIDE DETAILS MADE IN ALUMINIUM

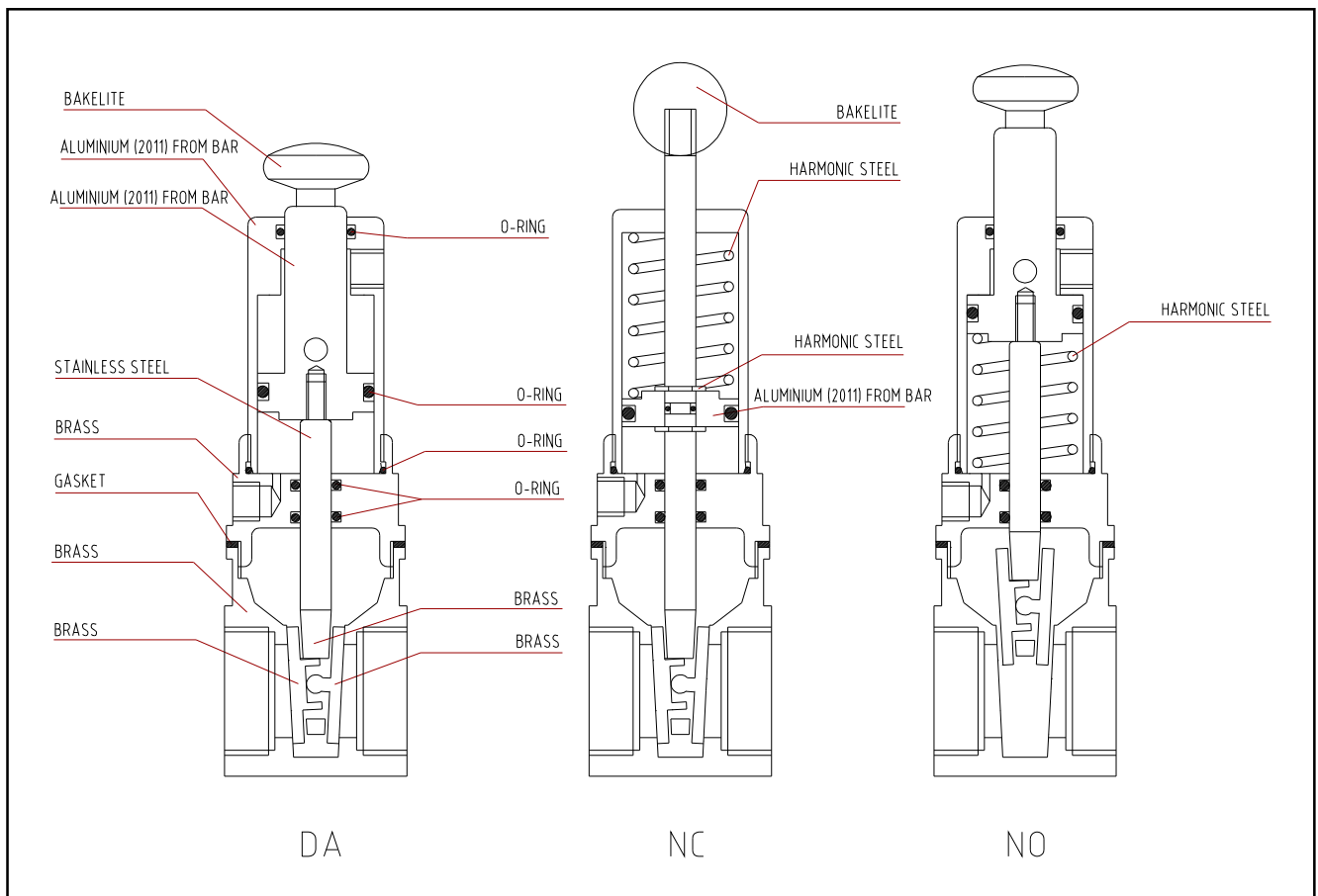

Art. "A"

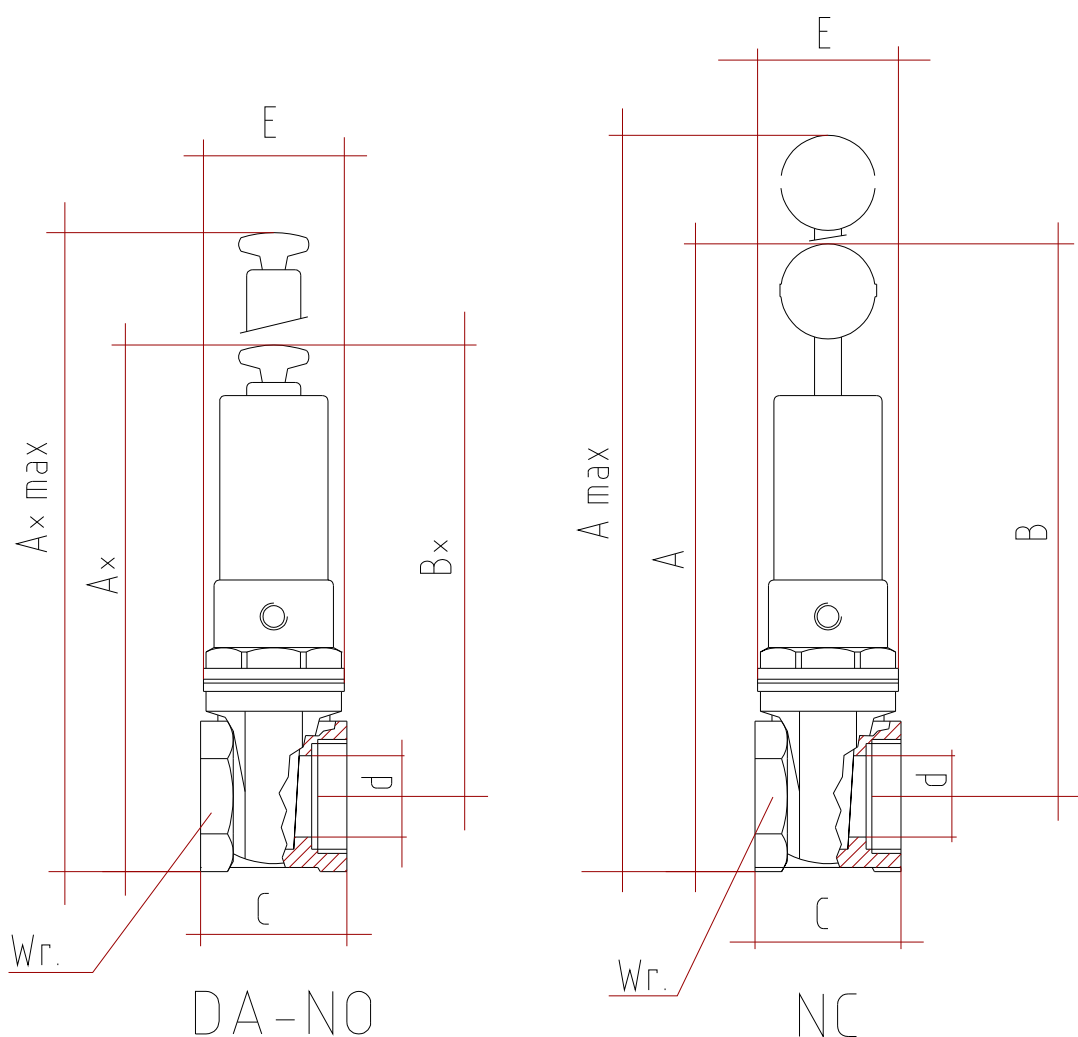

OVERALL DIMENSIONS

The dimensions with asterisk refer to DA and NO version

| DN | G | A | A* | A max. | A*max | B | B* | C | d | E | Wrench | KV | Weight |
|-----|-------|-----|-----|--------|-------|-----|-----|----|----|-----|--------|------|--------|
| mm | | mm | mm | mm | mm | mm | mm | mm | mm | mm | mm | m3/h | gr |
| 20 | 3/4" | 177 | 163 | 191 | 177 | 158 | 138 | 48 | 19 | 40 | 34 | 36 | 540 |
| 25 | 1" | 189 | 177 | 204 | 191 | 166 | 148 | 54 | 24 | 45 | 40 | 66 | 660 |
| 32 | 1"1/4 | 239 | 213 | 265 | 239 | 211 | 184 | 60 | 35 | 52 | 50 | 126 | 1200 |
| 40 | 1"1/2 | 243 | 228 | 268 | 253 | 211 | 197 | 64 | 37 | 57 | 56 | 180 | 1250 |
| 50 | 2" | 294 | 280 | 335 | 316 | 255 | 241 | 72 | 47 | 70 | 69 | 234 | 1950 |
| 65 | 2"1/2 | 329 | 311 | 371 | 353 | 282 | 264 | 80 | 59 | 84 | 85 | 360 | 2550 |
| 80 | 3" | 393 | 361 | 448 | 416 | 337 | 306 | 85 | 70 | 99 | 101 | 603 | 3850 |
| 100 | 4" | | 417 | | 503 | | 347 | 97 | 94 | 124 | 127 | 1200 | 6600 |