

# Technical Sheet

## Sliprings Type PMS

### Main Performances

<b>Housing</b>	In aluminium, suitable for installation in inside or outside area
<b>Positioning</b>	In vertical axis, with threaded pipe at the bottom
<b>Connections</b>	Rings cabled with 2 m long cable
<b>Cable entry</b>	Inside the fastener pipe for the rings and through the PG21 cable entry for the brush holders
<b>Brushes</b>	20 A or 50 A copper graphite / silver graphite for signals
<b>Executions</b>	From 6 to 30 rings 20 A - mixed executions 20/50 A
<b>Armonized rules</b>	EN 60947 - 5 - 1 EN 60529 2006/95/CE - 2004/108/CE - 2006/42/CE
<b>Marking</b>	CE

### Electrical Features

Nominal voltage	660 V ac - dc
Nominal current	lth 20 A - 50 A
Protection degree	IP 55
Max rotating speed	30 revs / min
Test voltage	2,5 kV
Operating temperature	- 20 °C ÷ + 60 °C



### Standard Types

Type	20 A N.° rings	H = mm *
G PMS B6	6	91
G PMS B10	10	91
G PMS B16	16	141
G PMS B20	20	141
G PMS B26	26	192
G PMS B30	30	192

Availability on demand:

- Types with 50 A rings
- Mixed executions with 50 A / 20 A rings
- Flat bottom version without housing pipe
- Signal versions with gold or silver rings

### Accessories

Availability on demand:

- Mercotac
- Absolut Encoder
- Micro-switches application
- Passages for air



## Installation and Wiring

The PMS slipring has to be installed only by qualified personnel in compliance with current safety standards. Power to the machine must be switched off before carrying out cabling. Connections are to be made in compliance with the wiring scheme of the controlled equipment. After installation has been completed, the installer is required to check that all commands are working properly. Avoid prolonged contact with oils and acids when using the equipment, as these may damage the products.

- 1) Using the locknuts (Ref. 27), attach the central pipe (Ref. 12) to a minimum 3 mm thick plate with a central hole of  $\varnothing 48.5 \div 52.5$  mm (using the reducing cable clip on the nuts). As an alternative the central pipe (Ref. 12) can be attached to a plate with a threaded hole of  $\varnothing 48$  mm, 1.5 mm pitch using the locknuts as jam nuts (Ref. 27).
- 2) Rotation is achieved thanks to 2  $\varnothing 10$  mm pivots (Ref. 24) situated on the base (Ref. 10) at a distance of 160 mm from each other. We recommend the coupling to be made with slack to take up any possible runout during rotation. Rotation can also be achieved by attaching the base (Ref. 10) using the two pivots (Ref. 24) situated on the plate, thus enabling the central pipe to rotate by (Ref. 12) thanks to a suitable coaxial joint.
- 3) The cables are connected to the brushes through the pipe union PG21 (Ref. 26). During the tightening of the cables to the brushes, brush holders must be locked. Please ensure that the wires do not interfere with any moving parts. The cables connected to the rings protrude from the central pipe by approx 2 m (Ref. 12). Longer cables are available upon request.
- 4) Please check the equipotential of any surfaces not generally recommended to be used under voltage, and the ground connection using the cables provided.

## Maintenance

A programme of periodical maintenance is required to be carried out to ensure that the PMS slipring is kept in perfect working order. All maintenance is to be effected by qualified personnel using only original spare parts. Any defective or altered parts must be replaced promptly, even outside the maintenance schedule, as they could impact on the safety of the device.

In particular:

- 1) Disconnect from power source and wait until the internal parts have cooled down.
- 2) Remove the cover (Ref. 5).
- 3) Check the brushes for wear and tear, and check that they adapt properly to the rings.
- 4) Remove copper-graphite dust with de-humidified compressed air or a clean brush.
- 5) Check tightness of cables.
- 6) Check that the cover seal is in good condition.
- 7) Replace cover (Ref. 5).

Please note that the guarantee does not cover any equipment whose parts have been modified and tampered.

RAVIOLI declines any responsibility for damage deriving from incorrect installation or use of the product.

## Dimensions

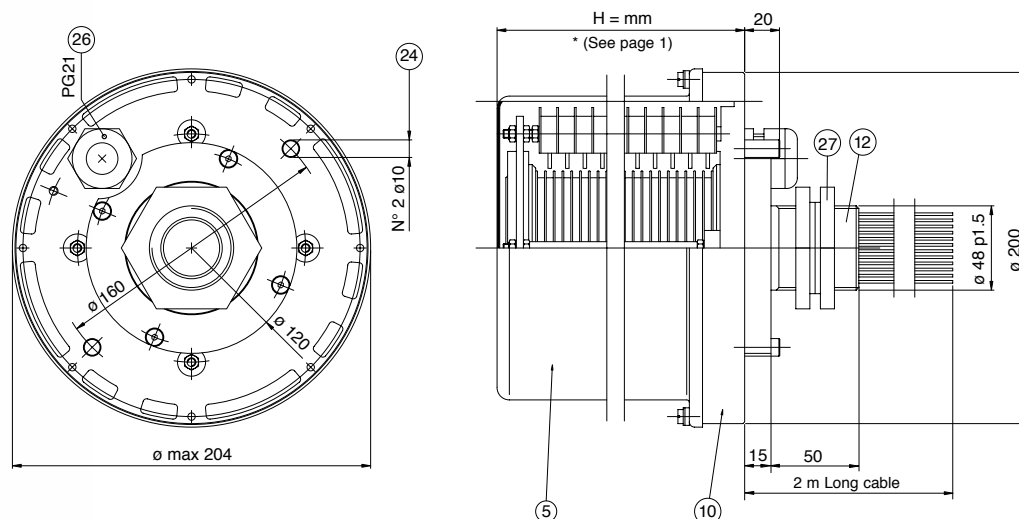

CE