



# ENAPART



93 S Railroad Avenue Unit C  
Bergenfield NJ 07621 USA  
[www.enapart.com](http://www.enapart.com)  
[sales@enapart.com](mailto:sales@enapart.com)



Via del Canneto 35,  
Borgosatollo, Brescia - Italia  
[www.enapart.it](http://www.enapart.it)  
[vendite@enapart.it](mailto:vendite@enapart.it)



Barbaros Mah. Ihlamur Bul. Aĝaoĝlu  
My Newwork No:3/15 Ataşehir / İstanbul  
[www.enapart.net](http://www.enapart.net)  
[satis@enapart.net](mailto:satis@enapart.net)



PRIVADA 10 B SUR #3908 COL.  
ANZUREZ, C.P. 72530, PUEBLA, PUE  
[www.enapart.com.mx](http://www.enapart.com.mx)  
[sales@enapart.com.mx](mailto:sales@enapart.com.mx)



Friedrich-Ebert-Anlage 36, 60325  
Frankfurt am Main, Germany  
[www.enapart.de](http://www.enapart.de)  
[anfrage@enapart.de](mailto:anfrage@enapart.de)



4 boulevard Carnot, 95400  
villiers-le-bel, Paris, France  
[www.enapart.fr](http://www.enapart.fr)  
[sales@enapart.fr](mailto:sales@enapart.fr)



65049, ОДЕСА, ВУЛИЦЯ ІВАНА  
ФРАНКА, БУДИНОК 55, ПОВЕРХ 3  
[www.enapart.com.ua](http://www.enapart.com.ua)  
[sales@enapart.com.ua](mailto:sales@enapart.com.ua)



MUNICIPIUL BUCUREȘTI, SECTOR 3,  
B-DUL BASARABIA, NR.250, CORP P+5  
[www.enapart.ro](http://www.enapart.ro)  
[sales@enapart.ro](mailto:sales@enapart.ro)



〒584-0023 大阪府富田林市若松町  
東2丁目2番16号  
[www.enapart.co.jp](http://www.enapart.co.jp)  
[sales@enapart.co.jp](mailto:sales@enapart.co.jp)



PLAZA NUESTRA SEÑORA DE LAS  
NIEVES 12 ,LOCAL ,50012,ZARAGOZA  
[www.enapart.es](http://www.enapart.es)  
[ventas@enapart.es](mailto:ventas@enapart.es)



Складова база „Онгъл“, Склад А2, п.к.  
4006, гр. Пловдив, България  
[www.enapart.bg](http://www.enapart.bg)  
[sales@enapart.bg](mailto:sales@enapart.bg)



3 Austin Mews, High Street, Hemel  
Hempstead, HP1 3AF , United Kingdom  
[www.enapart.co.uk](http://www.enapart.co.uk)  
[sales@enapart.co.uk](mailto:sales@enapart.co.uk)



# L SERIES

## PNEUMATIC CYLINDERS

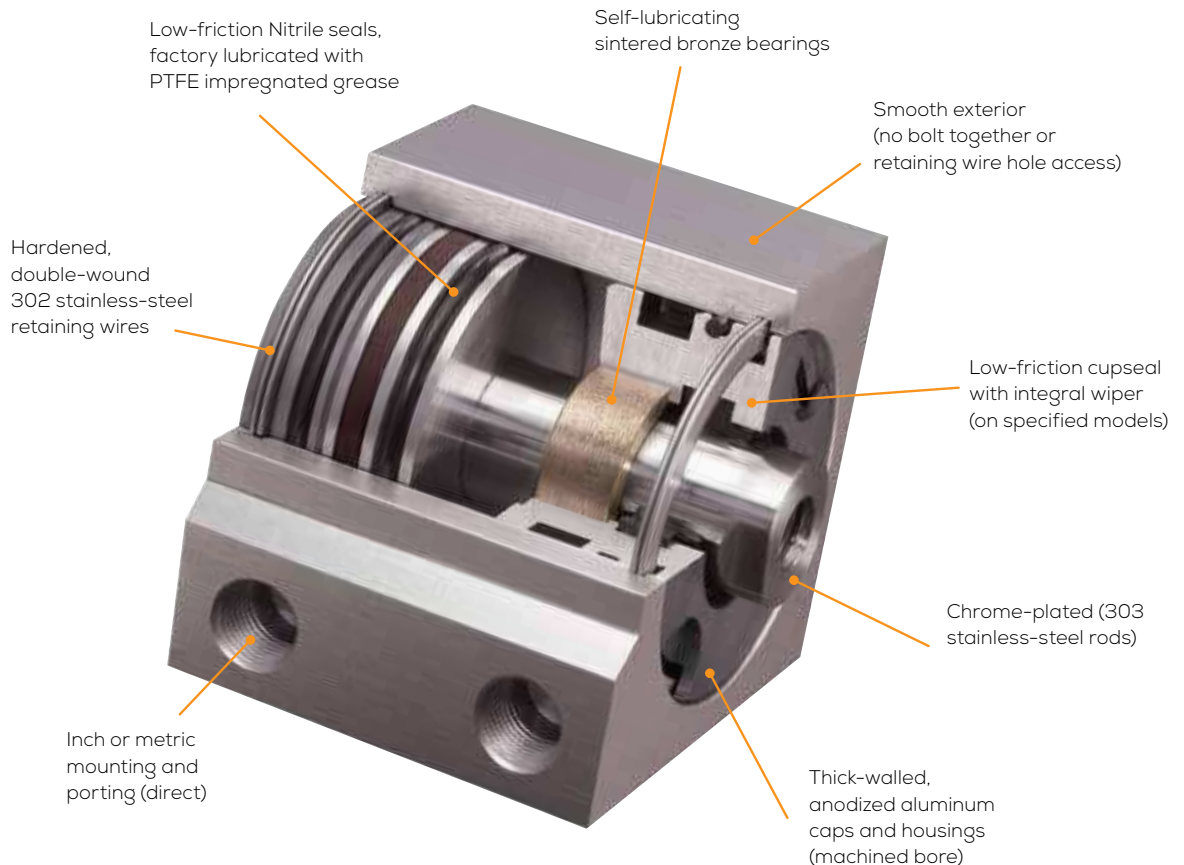

### Low Breakaway and Running Friction / Long Life

Designed for low start up and running friction, the L series contains low friction Nitrile seals and is lubricated at the factory with PTFE impregnated grease. Precision machined components and self-lubricating bearings ensure long life and continued low friction operation.

### Compact Size / Clean Design

Nason L series cylinders were designed with today's automation equipment in mind. They offer more power in a smaller package than comparable pancake or compact type cylinders. The smooth exterior of the cylinder body (no bolt together or retaining wire hole access) means no dirt or grease traps.

### Rugged Construction

The L series incorporates thick walled, anodized aluminum housings and caps. Rods are chrome plated 303 stainless steel riding in self-lubricating bronze bearings and hardened 302 stainless steel retaining wires are used for assembly.

### Rebuildable

All L series cylinders are field rebuildable.

### Versatile Design

The L series cylinders are metric in design (bore and rod sizes). They are offered in inch or metric mounting and porting. Due to their 100% machined design they are easily customized by Nason.

**Individual Features**

**Model LS**

- Most compact of 3 models

Double Acting, Single Rod

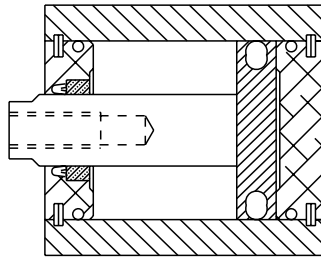

Type "D" - Double Acting, Double Rod

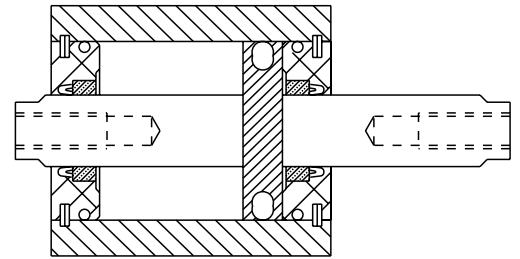

Type "R" - Single Acting, Spring Extend

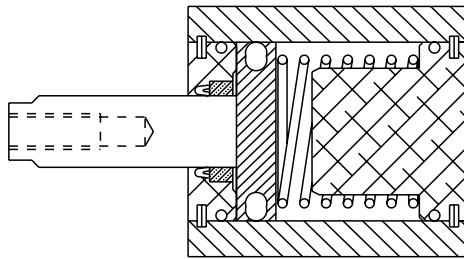

Type "S" - Single Acting, Spring Retract

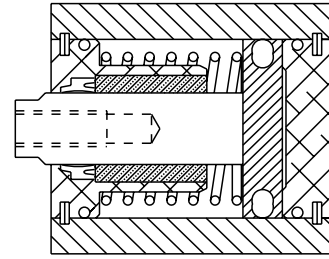

**Model LE**

- Extended internal rod bearing for additional load support
- Integral seal and rod wiper

Double Acting, Single Rod

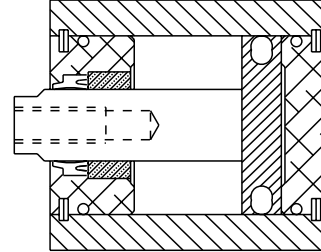

**Model LH**

- Extended internal rod bearing for additional load support
- Integral seal and rod wiper
- Wear band added to piston for additional load support

Double Acting, Single Rod

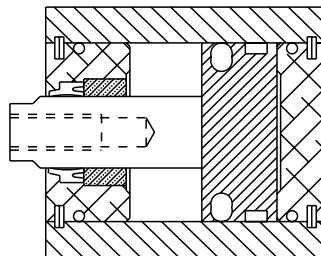

Type "D" - Double Acting, Double Rod

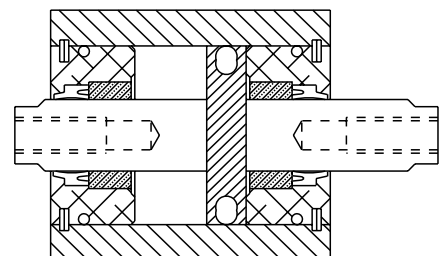

Example: Heavy Duty, 32mm Bore, 50mm stroke, Double Acting Single Rod, Tapped Mounting Both Ends, Nonmagnetic Piston, Inch threads, 17mm Total Rod Extension, Rod Stud

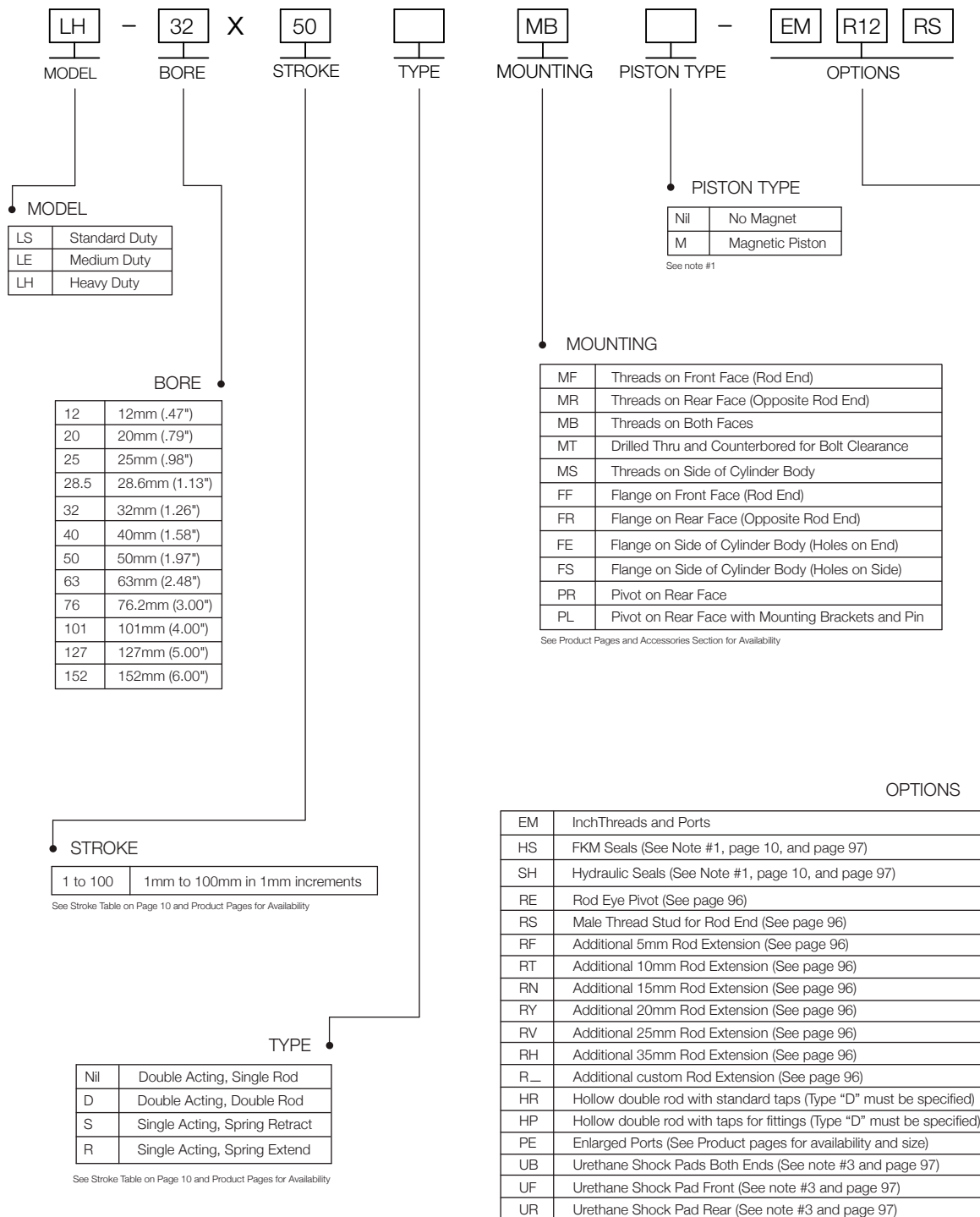

Note 1 - Magnetic Piston "M" limits temperature range to -10°C to 82°C (14°F to 180°F). This temperature rating overrides ALL OTHER TEMPERATURE ratings (Standard Seals, HS Seals, etc.). Magnetic Piston limits Pressure rating 250 PSI (1.7 MPa)

Note 2 - "R\_" Enter desired additional Custom Length Rod extension in mm after "R". Example LE-32X40MSM-EMR20.4 would have a TOTAL ROD EXTENSION of 25.4mm (20.4mm+Standard 5mm extension)

Note 3 - "UB", "UF", "UR" Urethane Shock Pads limit temperature range to -10°C to 82°C (14°F to 180°F). This temperature rating overrides ALL OTHER TEMPERATURE ratings (Standard Seals, HS Seals, etc.). Pads are mechanically retained at the Cap faces. "UB" OPTION CHANGES STROKE TOLERANCE TO +/-2mm. "UF" and "UR" OPTION CHANGES STROKE TOLERANCE TO +/-1mm.

## Piston Areas and Pressure Ratings

Bore	Piston Area Extend	Piston Area Retract	Maximum Pressure Ratings		
			Standard Pneumatic	Hydraulic (SH Option)	Magnetic (SH Option)
12	1,13 cm <sup>2</sup> (.18 in <sup>2</sup> )	0,85 cm <sup>2</sup> (.14 in <sup>2</sup> )	1.0 MPa (150 PSI)	NA	NA
20	3,14 cm <sup>2</sup> (.48in <sup>2</sup> )	2,64 cm <sup>2</sup> (.40in <sup>2</sup> )	1.7 MPa (250 PSI)	3.45 MPa (500 PSI)	1.7 MPa (250 PSI)
25	4,91 cm <sup>2</sup> (.76 in <sup>2</sup> )	4,12 cm <sup>2</sup> (.64 in <sup>2</sup> )	1.7 MPa (250 PSI)	3.45 MPa (500 PSI)	1.7 MPa (250 PSI)
28.5	6,41 cm <sup>2</sup> (1.0 in <sup>2</sup> )	5,28 cm <sup>2</sup> (.82 in <sup>2</sup> )	1.7 MPa (250 PSI)	3.45 MPa (500 PSI)	1.7 MPa (250 PSI)
32	8,04 cm <sup>2</sup> (1.25 in <sup>2</sup> )	6,91 cm <sup>2</sup> (1.07 in <sup>2</sup> )	1.7 MPa (250 PSI)	3.45 MPa (500 PSI)	1.7 MPa (250 PSI)
40	12,56 cm <sup>2</sup> (1.95 in <sup>2</sup> )	10,55 cm <sup>2</sup> (1.64 in <sup>2</sup> )	1.7 MPa (250 PSI)	3.45 MPa (500 PSI)	1.7 MPa (250 PSI)
50	19,63 cm <sup>2</sup> (3.04 in <sup>2</sup> )	17,62 cm <sup>2</sup> (2.73 in <sup>2</sup> )	1.7 MPa (250 PSI)	3.45 MPa (500 PSI)	1.7 MPa (250 PSI)
63	31,17 cm <sup>2</sup> (4.83 in <sup>2</sup> )	28,03 cm <sup>2</sup> (4.34 in <sup>2</sup> )	1.7 MPa (250 PSI)	3.45 MPa (500 PSI)	1.7 MPa (250 PSI)
76	45,6 cm <sup>2</sup> (7.07 in <sup>2</sup> )	42,46 cm <sup>2</sup> (6.59 in <sup>2</sup> )	1.7 MPa (250 PSI)	3.45 MPa (500 PSI)	1.7 MPa (250 PSI)
101	81,07 cm <sup>2</sup> (12.57 in <sup>2</sup> )	77,93 cm <sup>2</sup> (12.09 in <sup>2</sup> )	1.4 MPa (200 PSI)	NA	NA
127	126,7 cm <sup>2</sup> (19.6 in <sup>2</sup> )	123,5 cm <sup>2</sup> (19.1 in <sup>2</sup> )	1.4 MPa (200 PSI)	NA	NA
152	181, 46 cm <sup>2</sup> (28.2 in <sup>2</sup> )	176,55 cm <sup>2</sup> (27.45 in <sup>2</sup> )	1.4 MPa (200 PSI)	NA	NA

## Spring Forces for Type "S" and "R"

Bore	Stroke	Fully Compressed	Spring Rate
12	1mm - 25mm	2.72 kg (6 lbs)	.064 kg/mm (3.6 lbs/in)
20	1mm - 25mm	4.08 kg (9 lbs)	.098 kg/mm (5.5 lbs/in)
20	26mm - 50mm	4.40 kg (9.7 lbs)	.073 kg/mm (4.1 lbs/in)
25	1mm - 25mm	3.04 kg (6.7 lbs)	.063 kg/mm (3.5 lbs/in)
25	26mm - 50mm	3.13 kg (6.9 lbs)	.039 kg/mm (2.2 lbs/in)
28.5	1mm - 25mm	5.94 kg (13.1 lbs)	.134 kg/mm (7.53 lbs/in)
28.5	26mm - 50mm	6.07 kg (13.4 lbs)	.072 kg/mm (4.13 lbs/in)
32	1mm - 25mm	5.67 kg (12.5 lbs)	.134 kg/mm (7.53 lbs/in)
32	26mm - 50mm	6.03 kg (13.3 lbs)	.072 kg/mm (4.13 lbs/in)
40	1mm - 25mm	8.62 kg (19 lbs)	.198 kg/mm (11.1 lbs/in)
40	26mm - 50mm	9.03 kg (19.9 lbs)	.107 kg/mm (6.0 lbs/in)
50	1mm - 25mm	8.62 kg (19 lbs)	.198 kg/mm (11.1 lbs/in)
50	26mm - 50mm	9.03 kg (19.9 lbs)	.107 kg/mm (6.0 lbs/in)

## Specifications

Media (Standard and HS Seals)	Air - Clean, Dry Or Lubricated
Media (SH Seals)	Standard Mineral Hydraulic Fluid
Pre-Lubricated at Factory	Non-soap elastomer/PTFE thickener
Temp. Range (Std.)	-10°C to 93°C (14°F to 200°F)
Temp. Range (Mag. Piston)	-10°C to 82°C (14°F to 180°F) See Note 2 & 3
Temp. Range (UB Option)	-10°C to 82°C (14°F to 180°F) See Note 2 & 3
Temp. Range (HS Option)	-10°C to 150°C (14°F to 302°F) See Note 2 & 3
Stroke Tolerance (Std)	+1mm/-0 (+0.04"/-0)
Stroke Tolerance (UB)	+/-2mm (+/- .08")
Stroke Tolerance (UF)	+/-1mm (+/- .04")
Stroke Tolerance (UR)	+/-1mm (+/- .04")

Note 1 - Longer strokes and other increments available upon request  
 Note 2 - Magnetic Piston "M" limits temperature range to -10°C to 82°C (14°F to 180°F). This temperature rating overrides ALL OTHER TEMPERATURE ratings (Standard Seals, HS Seals, etc.). Magnetic Piston and Sensor mounting tracks are provided on Front Stroke Cylinder only.  
 Note 3 - "UB", "UF", "UR" Urethane Shock Pads limit temperature range to -10°C to 82°C (14°F to 180°F). This temperature rating overrides ALL OTHER TEMPERATURE ratings (Standard Seals, HS Seals, etc.). Pads are mechanically retained at the Cap faces. "UB" OPTION CHANGES STROKE TOLERANCE TO +/-2mm. "UF" and "UR" OPTION CHANGES STROKE TOLERANCE TO +/-1mm.  
 Note 4 - While all Models are offered in all strokes, it is recommended that strokes over 50mm use LE or LH Models for added bearing support.

## Available Strokes

Model LS - 10mm through 100mm in 1mm increments
Model LS with Magnetic Piston - 5mm through 100mm in 1mm increments
Models LE & LH (Standard and Magnetic Piston) - 5mm through 100mm in 1mm increments
Model LS, LE & LH 28.5mm Bore (Standard and Magnetic Piston) - 6.35mm through 101.6mm in 6.35mm increments
Model LS, Type S and R (Standard and Magnetic Piston) 12mm Bore - 5mm through 25mm in 1mm increments
Model LS, Type S and R (Standard and Magnetic Piston) 20mm Bore Thru 50mm Bore - 5mm through 50mm in 1mm increments
Model LS, Type S and R 28.5mm Bore (Standard and Magnetic Piston) - 6.35mm through 50.8mm in 6.35mm increments

See note #1 and #4

## Stock Strokes for Quick Delivery

Ship in 2-3 Days  
 Models LS, LE, and LH  
 Standard and Magnetic Pistons  
 Mounting Styles MF, MR, MB, MT, and MS  
 Metric and Inch Threads  
 Single Rod End Type Cylinders

Bore Sizes - 20mm, 25mm, 32mm			
1-10 pieces	Stock Strokes (Ship 2-3 days)		
Model	LS	LE	LH
Standard Piston	20mm	15mm	10mm
Magnetic Piston	15mm	10mm	5mm
Standard Piston	30mm	25mm	20mm
Magnetic Piston	25mm	20mm	15mm
Standard Piston	45mm	40mm	35mm
Magnetic Piston	40mm	35mm	30mm
Standard Piston	55mm	50mm	45mm
Magnetic Piston	50mm	45mm	40mm
Standard Piston	70mm	65mm	60mm
Magnetic Piston	65mm	60mm	55mm
Standard Piston	80mm	75mm	70mm
Magnetic Piston	75mm	70mm	65mm

Bore Sizes - 40mm, 50mm			
1-10 pieces	Stock Strokes (Ship 2-3 days)		
Model	LS	LE	LH
Standard Piston	25mm	15mm	10mm
Magnetic Piston	20mm	10mm	5mm
Standard Piston	35mm	25mm	20mm
Magnetic Piston	30mm	20mm	15mm
Standard Piston	50mm	40mm	35mm
Magnetic Piston	45mm	35mm	30mm
Standard Piston	60mm	50mm	45mm
Magnetic Piston	55mm	45mm	40mm
Standard Piston	75mm	65mm	60mm
Magnetic Piston	70mm	60mm	55mm
Standard Piston	85mm	75mm	70mm
Magnetic Piston	80mm	70mm	65mm

### Strokes

Bore Size	Standard (Non-Magnetic)		5mm	10mm	15mm	20mm	25mm	30mm	35mm	40mm	45mm	50mm	55mm	60mm	65mm	70mm	75mm	80mm	85mm	
20mm	Model	LS				*		*			*		*			*		*		
		LE			*		*			*		*		*		*		*		
		LH		*		*			*		*		*		*		*		*	
25mm	Magnetic Piston		5mm	10mm	15mm	20mm	25mm	30mm	35mm	40mm	45mm	50mm	55mm	60mm	65mm	70mm	75mm	80mm	85mm	
		Model	LS			*		*			*		*		*		*		*	
			LE		*		*			*		*		*		*		*		*
LH	*			*			*		*		*		*		*		*			
32mm	Model	LS			*		*			*		*		*		*		*		
		LE		*		*			*		*		*		*		*		*	
		LH	*		*			*		*		*		*		*		*		

### Strokes

Bore Size	Standard (Non-Magnetic)		5mm	10mm	15mm	20mm	25mm	30mm	35mm	40mm	45mm	50mm	55mm	60mm	65mm	70mm	75mm	80mm	85mm	
40mm	Model	LS					*		*			*		*		*		*		
		LE			*		*			*		*		*		*		*		
		LH		*		*			*		*		*		*		*		*	
50mm	Magnetic Piston		5mm	10mm	15mm	20mm	25mm	30mm	35mm	40mm	45mm	50mm	55mm	60mm	65mm	70mm	75mm	80mm	85mm	
		Model	LS			*		*			*		*		*		*		*	
			LE		*		*			*		*		*		*		*		*
LH	*			*			*		*		*		*		*		*			

### Non Magnetic Front Mount Cylinder "MF"

MODEL	TYPE	STANDARD STROKES	"A"	PISTON AREA
LS	-	10mm - 50mm	16,0(0.63")	PUSH 1,13 cm <sup>2</sup> (0.18 in <sup>2</sup> )
LE	-	5mm - 50mm	21,0(0.83")	
LH	-	5mm - 50mm	26,0(1.03")	PULL 0,85 cm <sup>2</sup> (0.14 in <sup>2</sup> )
LS	S,R	5mm - 25mm	31,0(1.22")	

	Standard Threads	"EM" Option
"B"	M5X0,8	#10-32
"C"	M4X0,7	#8-32
"D"	M4X0,7	#8-32

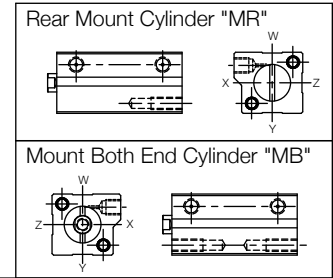
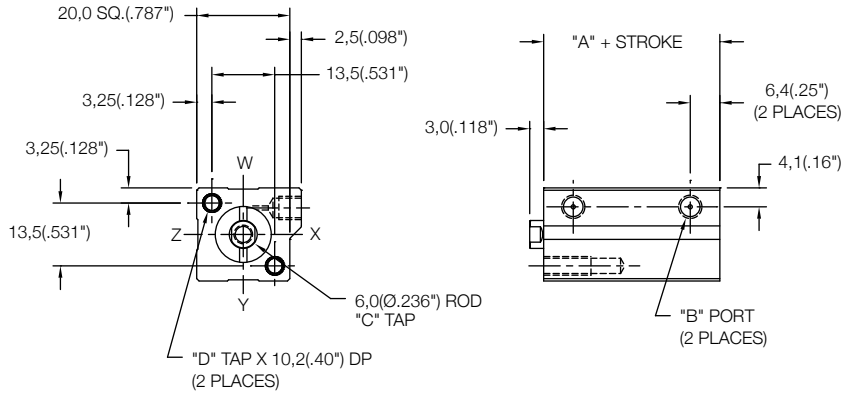

### Non Magnetic Thru Mount Cylinder "MT"

MODEL	TYPE	STANDARD STROKES	"A"	PISTON AREA
LS	-	10mm - 20mm	16,0(0.63")	PUSH 1,13 cm <sup>2</sup> (0.18 in <sup>2</sup> )
LE	-	5mm - 15mm	21,0(0.83")	
LH	-	5mm - 10mm	26,0(1.03")	PULL 0,85 cm <sup>2</sup> (0.14 in <sup>2</sup> )
LS	S,R	5mm	31,0(1.22")	

	Standard Threads	"EM" Option
"B"	M5X0,8	#10-32
"C"	M4X0,7	#8-32

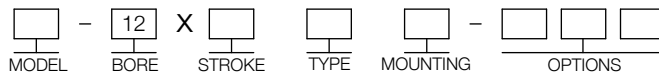
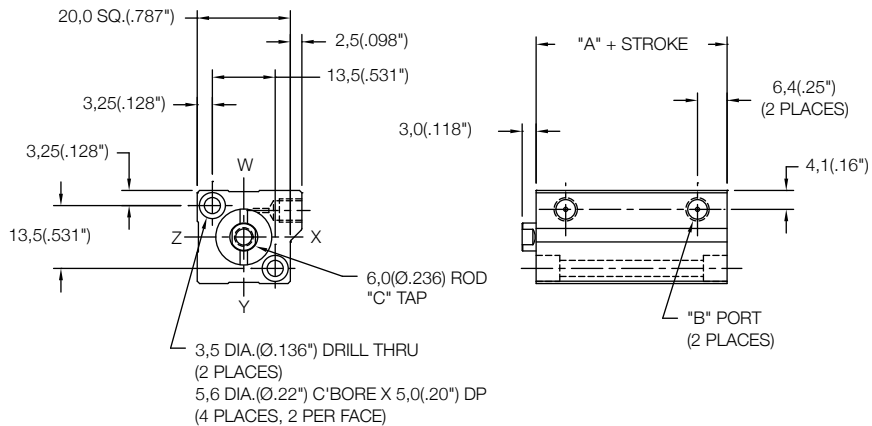

MODEL  
LS  
LE  
LH

5mm - 50mm STROKE  
(SEE STROKE RANGE)

BLANK - NO CODE, DOUBLE  
ACTING, SINGLE ROD  
S - SINGLE ACTING, SPRING RETRACT  
R - SINGLE ACTING, SPRING EXTEND

MT - THRU MOUNT  
MF - FRONT MOUNT  
MR - REAR MOUNT  
MB - BOTH END MOUNTS  
FF - FRONT FLANGE  
FR - REAR FLANGE  
(FOR FLANGES SEE PAGE 92)  
PR - REAR PIVOT  
(FOR PIVOT SEE PAGE 94)

EM - INCH THREADS & PORT OPTIONS

HS - HIGH TEMPERATURE SEALS OPTION:  
AVAILABLE ON LE AND LH MODELS ONLY  
(SEE PAGE 97)

RE - ROD EYE  
(SEE PAGE 96)

RS - MALE STUD FOR ROD END  
(SEE PAGE 96)

RF, RH, RN, RT, RV, RY - ROD EXTENSIONS  
(SEE PAGE 96)



### Magnetic Front Mount Cylinder "MF"

MODEL	TYPE	STANDARD STROKES	"A"	PISTON AREA
LS	-	10mm - 50mm	26,0(1.03")	PUSH 1,13 cm <sup>2</sup> (0.18 in <sup>2</sup> )
LE	-	5mm - 50mm	31,0(1.23")	
LH	-	5mm - 50mm	36,0(1.42")	PULL 0,85 cm <sup>2</sup> (0.14 in <sup>2</sup> )
LS	S,R	5mm - 25mm	41,0(1.62")	

	Standard Threads	"EM" Option
"B"	M5X0,8	#10-32
"C"	M4X0,7	#8-32
"D"	M4X0,7	#8-32

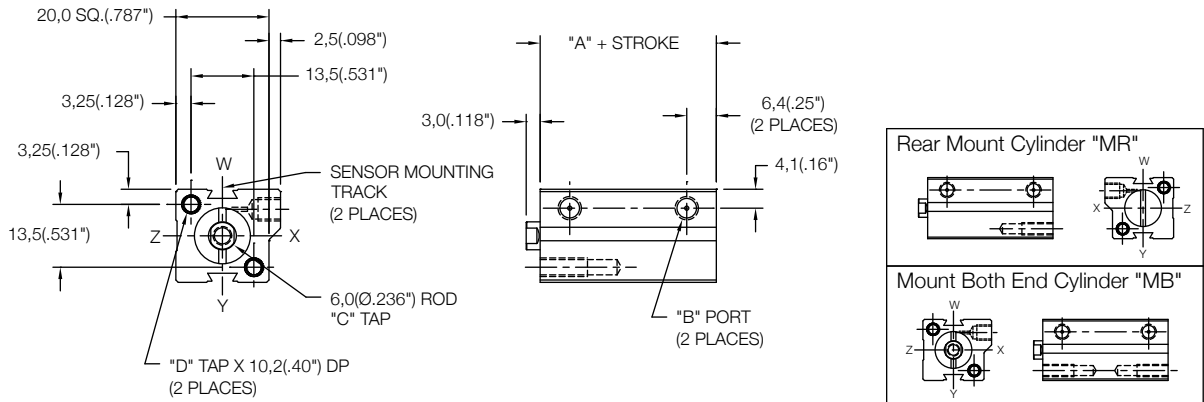

### Magnetic Thru Mount Cylinder "MT"

MODEL	TYPE	STANDARD STROKES	"A"	PISTON AREA
LS	-	10mm	26,0(1.03")	PUSH 1,13 cm <sup>2</sup> (0.18 in <sup>2</sup> )
LE	-	5mm	31,0(1.23")	

	Standard Threads	"EM" Option
"B"	M5X0,8	#10-32
"C"	M4X0,7	#8-32

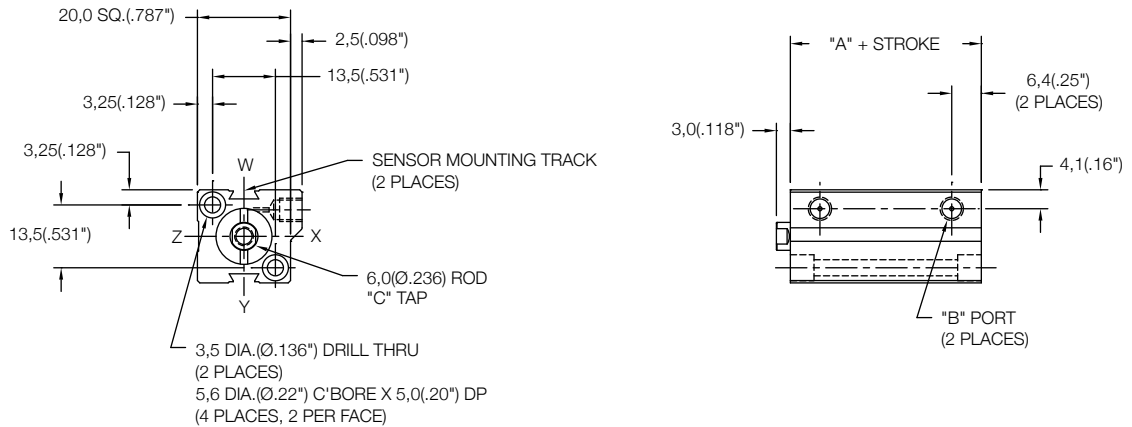

MODEL - 12 X STROKE TYPE MOUNTING MAGNETIC - OPTIONS

MODEL: LS, LE, LH  
 STROKE: 5mm - 50mm (SEE STROKE RANGE)  
 TYPE: BLANK - NO CODE, DOUBLE ACTING, SINGLE ROD; S - SINGLE ACTING, SPRING RETRACT; R - SINGLE ACTING, SPRING EXTEND  
 MOUNTING: MT - THRU MOUNT; MF - FRONT MOUNT; MR - REAR MOUNT; MB - BOTH END MOUNTS; FF - FRONT FLANGE; FR - REAR FLANGE (FOR FLANGES SEE PAGE 92); PR - REAR PIVOT (FOR PIVOT SEE PAGE 94)

SENSORS SOLD SEPARATELY  
 SKS, SKP, SCS, SCP - SOLID STATE  
 LIMIT SENSORS (SEE PAGE 88)

- EM - INCH THREADS & PORT OPTIONS
- HS - HIGH TEMPERATURE SEALS OPTION: AVAILABLE ON LE AND LH MODELS ONLY (SEE PAGE 97)
- RE - ROD EYE (SEE PAGE 96)
- RS - MALE STUD FOR ROD END (SEE PAGE 96)
- RF, RH, RN, RT, RV, RY - ROD EXTENSIONS (SEE PAGE 96)

### Magnetic Side Mount Cylinder "MS"

MODEL	TYPE	STANDARD STROKES	"A"	PISTON AREA
LS	-	10mm	26,0(1.03")	PUSH 1,13 cm <sup>2</sup> (0.18 in <sup>2</sup> )
LE	-	5mm	31,0(1.23")	PULL 0,85 cm <sup>2</sup> (0.14 in <sup>2</sup> )

	Standard Threads	"EM" Option
"B"	M5X0,8	#10-32
"C"	M4X0,7	#8-32
"D"	M3X0,5	#4-40

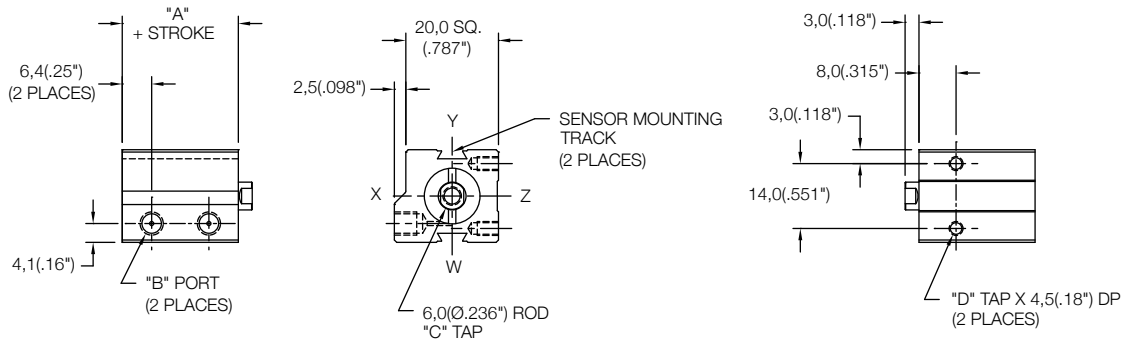

### Magnetic Side Mount Cylinder "MS"

MODEL	TYPE	STANDARD STROKES	"A"	PISTON AREA
LS	-	15mm - 50mm	26,0(1.03")	PUSH 1,13 cm <sup>2</sup> (0.18 in <sup>2</sup> )
LE	-	10mm - 50mm	31,0(1.23")	
LH	-	5mm - 50mm	36,0(1.42")	PULL 0,85 cm <sup>2</sup> (0.14 in <sup>2</sup> )
LS	S,R	5mm - 25mm	41,0(1.62")	

	Standard Threads	"EM" Option
"B"	M5X0,8	#10-32
"C"	M4X0,7	#8-32
"D"	M3X0,5	#4-40

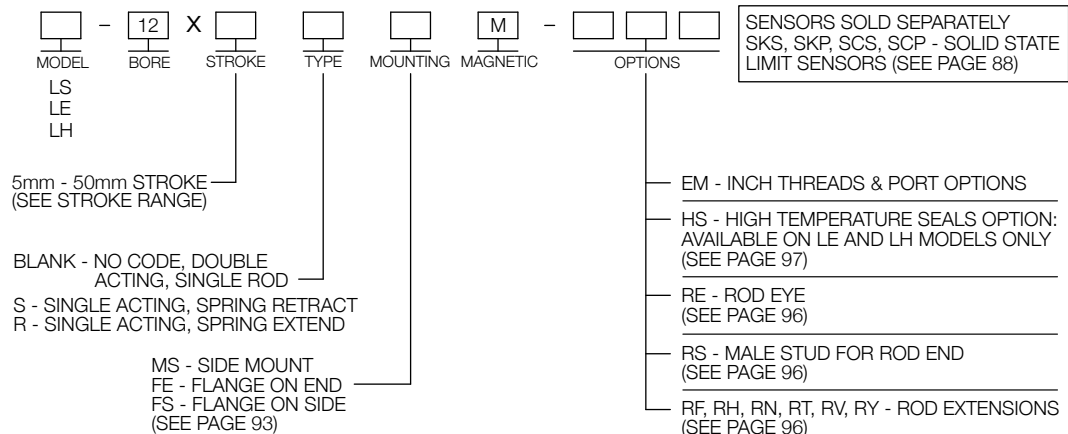
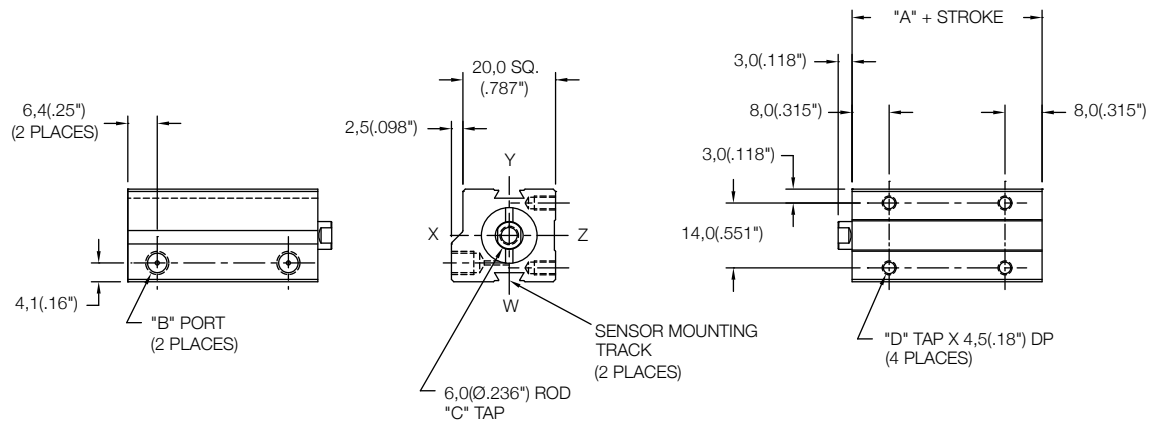

### Non Magnetic Side Mount Cylinder "MS"

MODEL	TYPE	STANDARD STROKES	"A"	PISTON AREA
LS	-	10mm - 20mm	16,0(0.63")	PUSH 1,13 cm <sup>2</sup> (0.18 in <sup>2</sup> )
LE	-	5mm - 15mm	21,0(0.83")	
LH	-	5mm - 10mm	26,0(1.03")	
LS	S,R	5mm	31,0(1.22")	PULL 0,85 cm <sup>2</sup> (0.14 in <sup>2</sup> )

	Standard Threads	"EM" Option
"B"	M5X0,8	#10-32
"C"	M4X0,7	#8-32
"D"	M3X0,5	#4-40

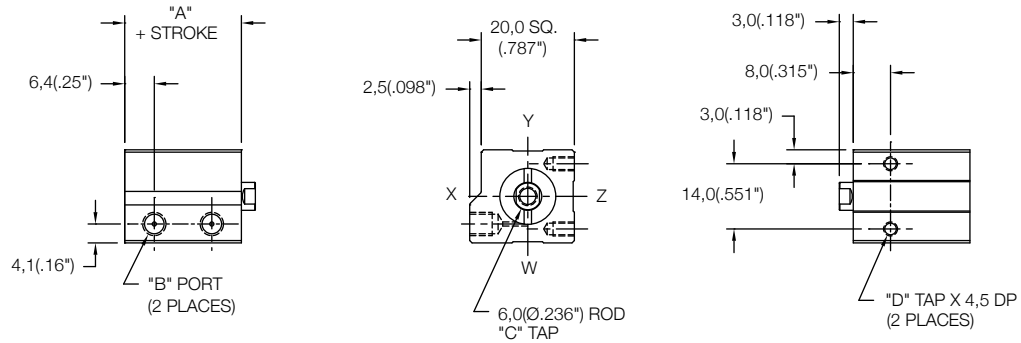

### Non Magnetic Side Mount Cylinder "MS"

MODEL	TYPE	STANDARD STROKES	"A"	PISTON AREA
LS	-	25mm - 50mm	16,0(0.63")	PUSH 1,13 cm <sup>2</sup> (0.18 in <sup>2</sup> )
LE	-	20mm - 50mm	21,0(0.83")	
LH	-	15mm - 50mm	26,0(1.03")	
LS	S,R	10mm - 25mm	31,0(1.22")	PULL 0,85 cm <sup>2</sup> (0.14 in <sup>2</sup> )

	Standard Threads	"EM" Option
"B"	M5X0,8	#10-32
"C"	M4X0,7	#8-32
"D"	M3X0,5	#4-40

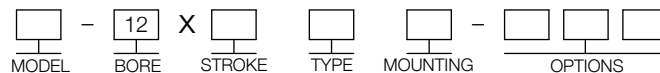
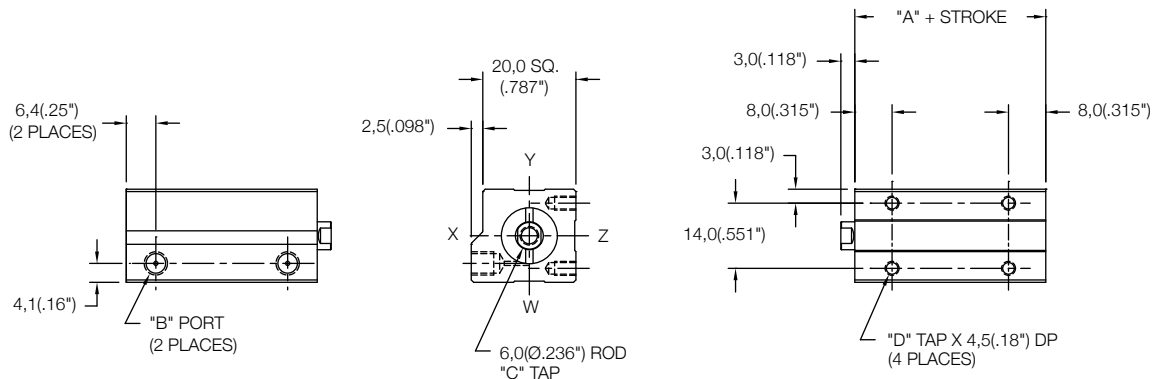

MODEL  
LS  
LE  
LH

5mm - 50mm STROKE  
(SEE STROKE RANGE)

BLANK - NO CODE, DOUBLE ACTING, SINGLE ROD  
S - SINGLE ACTING, SPRING RETRACT  
R - SINGLE ACTING, SPRING EXTEND

MS - SIDE MOUNT  
FE - FLANGE ON END  
FS - FLANGE ON SIDE  
(SEE PAGE 93)

EM - INCH THREADS & PORT OPTIONS  
HS - HIGH TEMPERATURE SEALS OPTION:  
AVAILABLE ON LE AND LH MODELS ONLY  
(SEE PAGE 97)  
RE - ROD EYE  
(SEE PAGE 96)  
RS - MALE STUD FOR ROD END  
(SEE PAGE 96)  
RF, RH, RN, RT, RV, RY - ROD EXTENSIONS  
(SEE PAGE 96)



### Magnetic Front Mount Cylinder "MF"

MODEL	TYPE	STANDARD STROKES	"A"	PISTON AREA
LS	_D	5mm - 100mm	23,5(0.93")	PUSH 3,14 cm <sup>2</sup> (0.48 in <sup>2</sup> )
LE	_	5mm - 100mm	28,5(1.12")	
LH	_D	5mm - 100mm	33,5(1.32")	
LS	S,R	5mm - 50mm	38,5(1.52")	PULL 2,64 cm <sup>2</sup> (0.40 in <sup>2</sup> )

	Standard Threads	"EM" Option
"B"	M5X0,8	#10-32
"C"	M5X0,8	#10-32
"D"	M5X0,8	#10-32

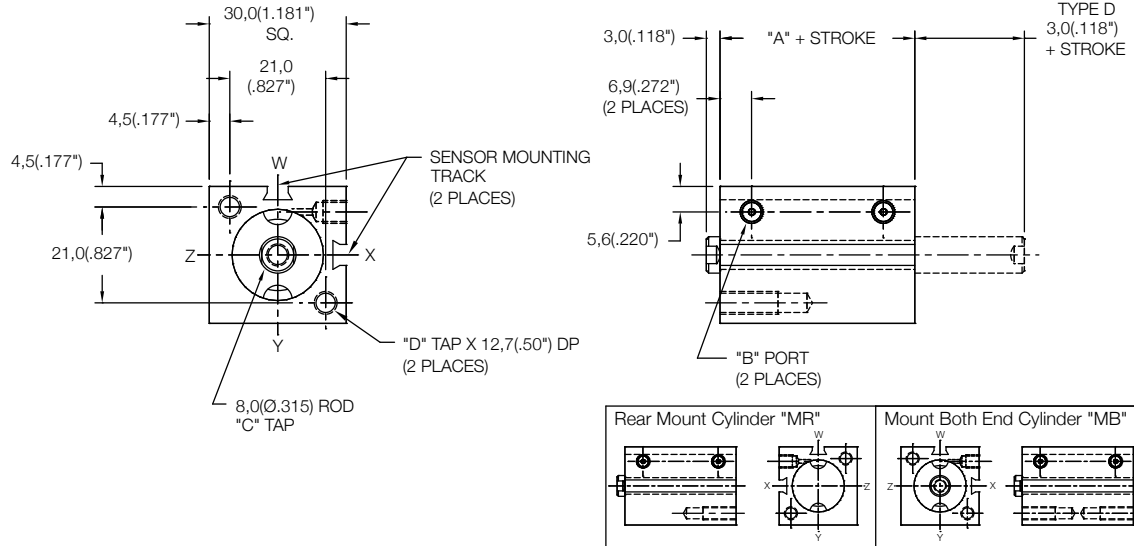

### Magnetic Thru Mount Cylinder "MT"

MODEL	TYPE	STANDARD STROKES	"A"	PISTON AREA
LS	_D	5mm - 20mm	23,5(0.93")	PUSH 3,14 cm <sup>2</sup> (0.48 in <sup>2</sup> )
LE	_	5mm - 15mm	28,5(1.12")	
LH	_D	5mm - 10mm	33,5(1.32")	
LS	S,R	5mm	38,5(1.52")	PULL 2,64 cm <sup>2</sup> (0.40 in <sup>2</sup> )

	Standard Threads	"EM" Option
"B"	M5X0,8	#10-32
"C"	M5X0,8	#10-32

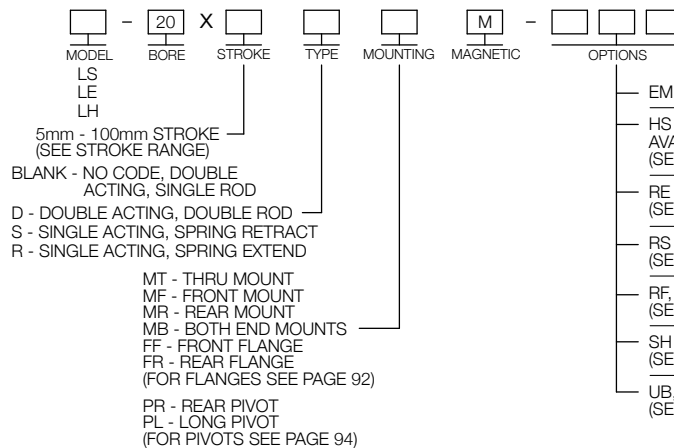
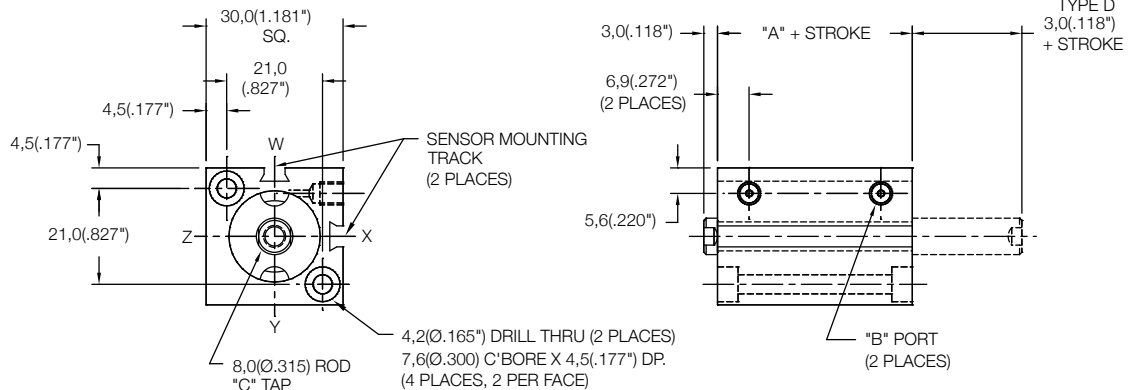

SENSORS SOLD SEPARATELY  
SKS, SKP, SCS, SCP - SOLID STATE  
LIMIT SENSORS (SEE PAGE 88)

## Magnetic Side Mount Cylinder "MS"

MODEL	TYPE	STANDARD STROKES	"A"	PISTON AREA
LS	_,D	5mm - 15mm	23,5(0.93")	PUSH 3,14 cm <sup>2</sup> (0.48 in <sup>2</sup> )
LE	-	5mm - 10mm	28,5(1.12")	
LH	_,D	5mm	33,5(1.32")	PULL 2,64 cm <sup>2</sup> (0.40 in <sup>2</sup> )

	Standard Threads	"EM" Option
"B"	M5X0,8	#10-32
"C"	M5X0,8	#10-32
"D"	M4X0,7	#8-32

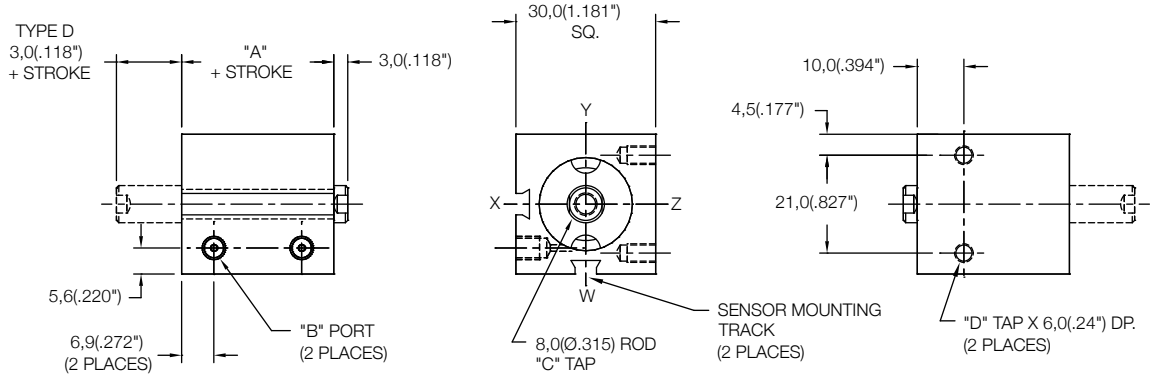

## Magnetic Side Mount Cylinder "MS"

MODEL	TYPE	STANDARD STROKES	"A"	PISTON AREA
LS	_,D	20mm - 100mm	23,5(0.93")	PUSH 3,14 cm <sup>2</sup> (0.48 in <sup>2</sup> )
LE	-	15mm - 100mm	28,5(1.12")	
LH	_,D	10mm - 100mm	33,5(1.32")	PULL 2,64 cm <sup>2</sup> (0.40 in <sup>2</sup> )
LS	S,R	5mm - 50mm	38,5(1.52")	

	Standard Threads	"EM" Option
"B"	M5X0,8	#10-32
"C"	M5X0,8	#10-32
"D"	M4X0,7	#8-32

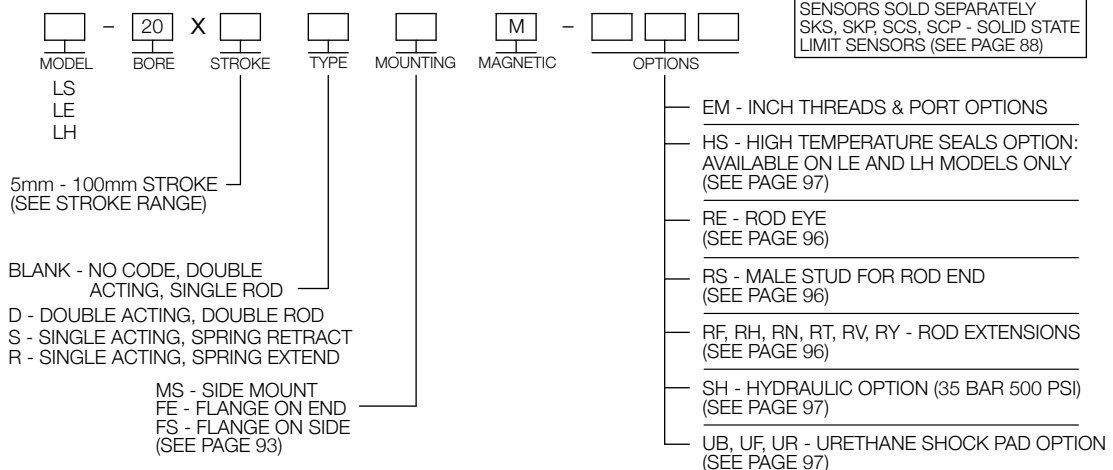
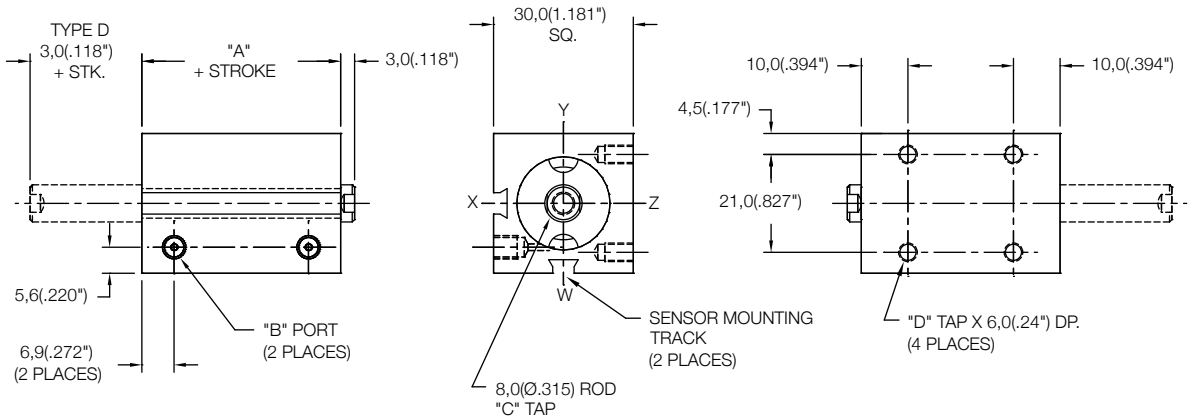

## Non Magnetic Side Mount Cylinder "MS"

MODEL	TYPE	STANDARD STROKES	"A"	PISTON AREA
LS	...D	10mm - 20mm	18,5(0.73")	PUSH 3,14 cm <sup>2</sup> (0.48 in <sup>2</sup> )
LE	-	5mm - 15mm	23,5(0.93")	
LH	...D	5mm - 10mm	28,5(1.12")	PULL 2,64 cm <sup>2</sup> (0.40 in <sup>2</sup> )
LS	S,R	5mm	33,5(1.32")	

	Standard Threads	"EM" Option
"B"	M5X0,8	#10-32
"C"	M5X0,8	#10-32
"D"	M4X0,7	#8-32

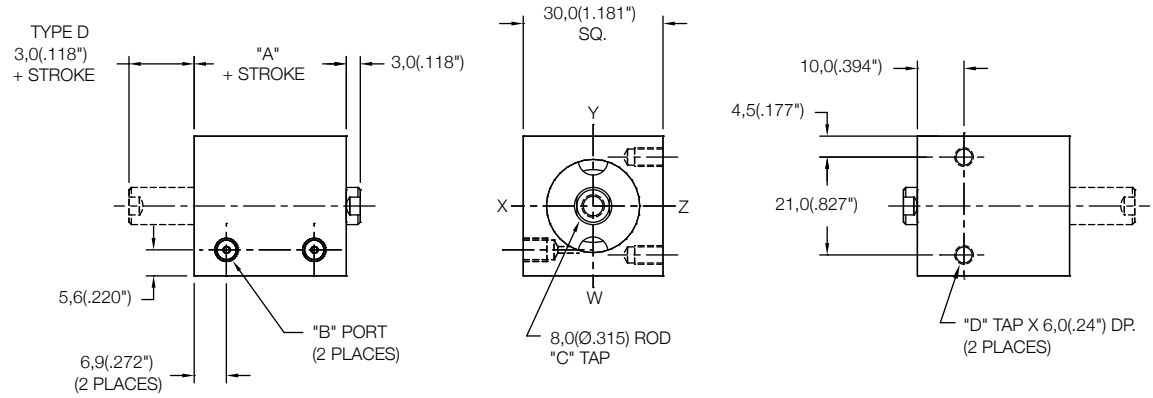

## Non Magnetic Side Mount Cylinder "MS"

MODEL	TYPE	STANDARD STROKES	"A"	PISTON AREA
LS	...D	25mm - 100mm	18,5(0.73")	PUSH 3,14 cm <sup>2</sup> (0.48 in <sup>2</sup> )
LE	-	20mm - 100mm	23,5(0.93")	
LH	...D	15mm - 100mm	28,5(1.12")	PULL 2,64 cm <sup>2</sup> (0.40 in <sup>2</sup> )
LS	S,R	10mm - 50mm	33,5(1.32")	

	Standard Threads	"EM" Option
"B"	M5X0,8	#10-32
"C"	M5X0,8	#10-32
"D"	M4X0,7	#8-32

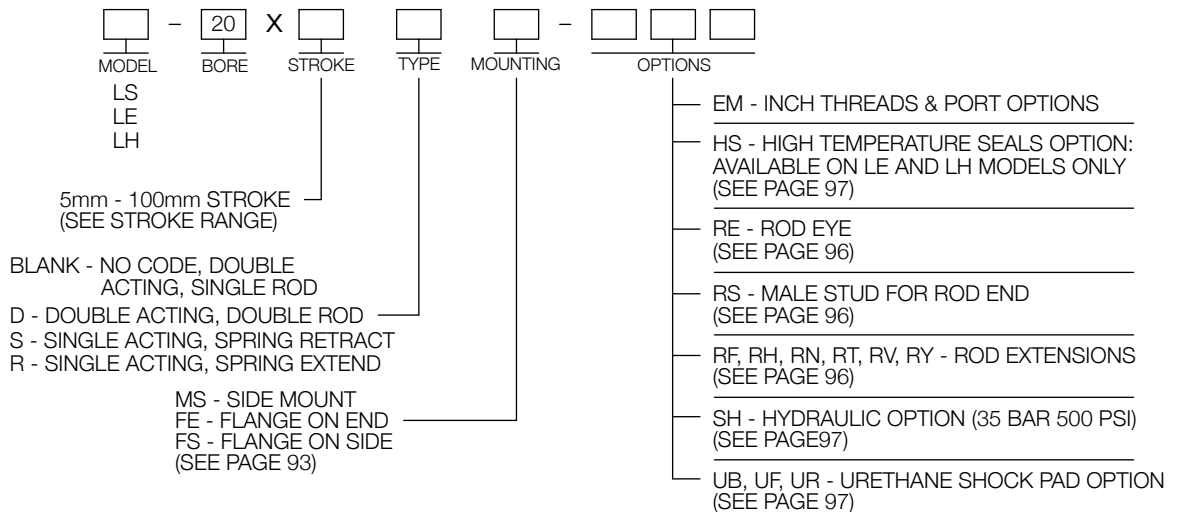
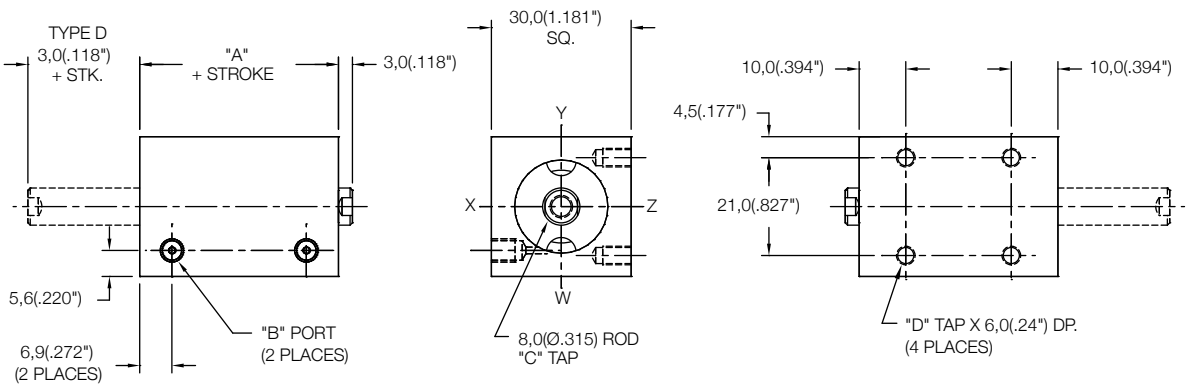

### Non Magnetic Front Mount Cylinder "MF"

MODEL	TYPE	STANDARD STROKES	"A"	PISTON AREA
LS	_,D	10mm - 100mm	19,0(0.75")	PUSH 4,91 cm <sup>2</sup> (0.76 in <sup>2</sup> )
LE	_	5mm - 100mm	24,0(0.95")	
LH	_,D	5mm - 100mm	29,0(1.14")	PULL 4,12 cm <sup>2</sup> (0.64 in <sup>2</sup> )
LS	S,R	5mm - 25mm	34,0(1.34")	
LS	S,R	26mm - 50mm	39,0(1.54")	

	Standard Threads	"EM" Option
"B"	M5X0,8	#10-32
"C"	M5X0,8	#10-32
"D"	M5X0,8	#10-32

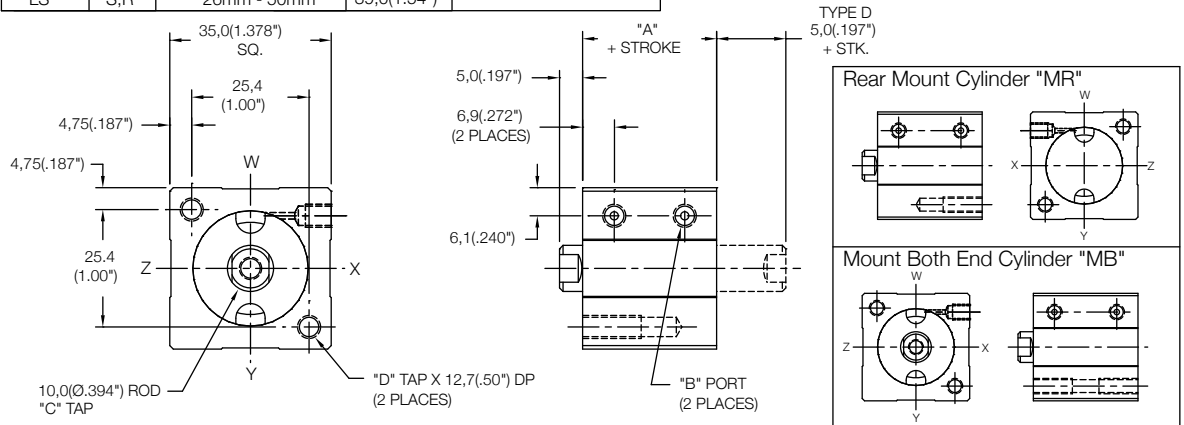

### Non Magnetic Thru Mount Cylinder "MT"

MODEL	TYPE	STANDARD STROKES	"A"	PISTON AREA
LS	_,D	10mm - 25mm	19,0(0.75")	PUSH 4,91 cm <sup>2</sup> (0.76 in <sup>2</sup> )
LE	_	5mm - 20mm	24,0(0.95")	
LH	_,D	5mm - 15mm	29,0(1.14")	PULL 4,12 cm <sup>2</sup> (0.64 in <sup>2</sup> )
LS	S,R	5mm - 10mm	34,0(1.34")	

	Standard Threads	"EM" Option
"B"	M5X0,8	#10-32
"C"	M5X0,8	#10-32

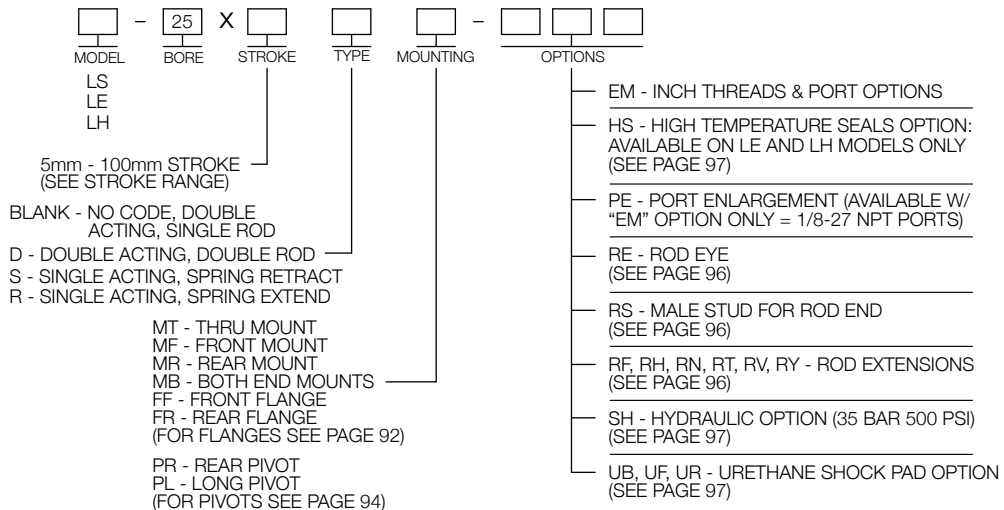
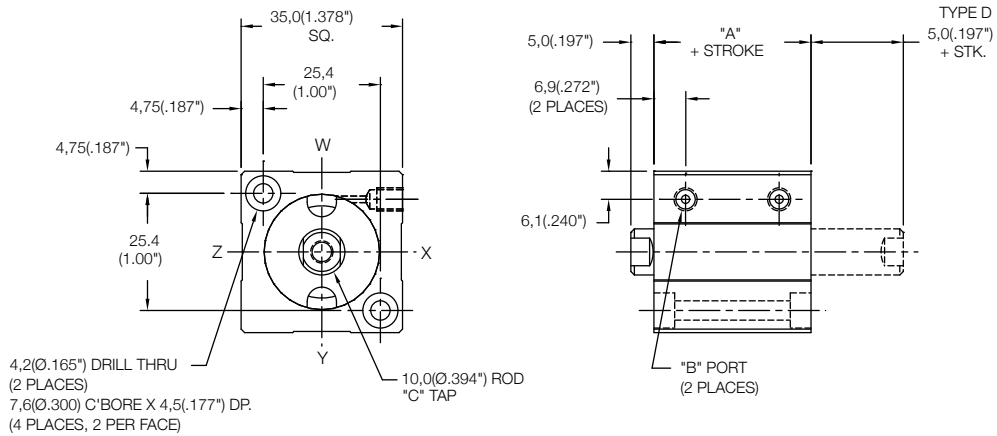



### Magnetic Front Mount Cylinder "MF"

MODEL	TYPE	STANDARD STROKES	"A"	PISTON AREA
LS	_D	5mm - 50mm	24,0(0.95")	PUSH 4,91 cm <sup>2</sup> (0.76 in <sup>2</sup> )
LE	-	5mm - 100mm	29,0(1.14")	
LH	_D	5mm - 100mm	34,0(1.34")	PULL 4,12 cm <sup>2</sup> (0.64 in <sup>2</sup> )
LS	S,R	5mm - 25mm	39,0(1.54")	
LS	S,R	26mm - 50mm	44,0(1.74")	

	Standard Threads	"EM" Option
"B"	M5X0,8	#10-32
"C"	M5X0,8	#10-32
"D"	M5X0,8	#10-32

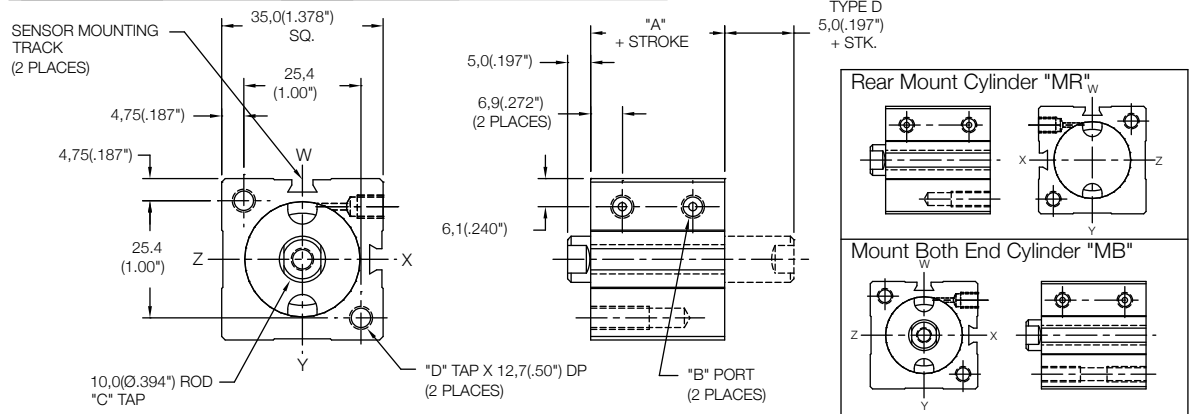

### Magnetic Thru Mount Cylinder "MT"

MODEL	TYPE	STANDARD STROKES	"A"	PISTON AREA
LS	_D	5mm - 20mm	24,0(0.95")	PUSH 4,91 cm <sup>2</sup> (0.76 in <sup>2</sup> )
LE	-	5mm - 15mm	29,0(1.14")	
LH	_D	5mm - 10mm	34,0(1.34")	PULL 4,12 cm <sup>2</sup> (0.64 in <sup>2</sup> )
LS	S,R	5mm	39,0(1.54")	

	Standard Threads	"EM" Option
"B"	M5X0,8	#10-32
"C"	M5X0,8	#10-32

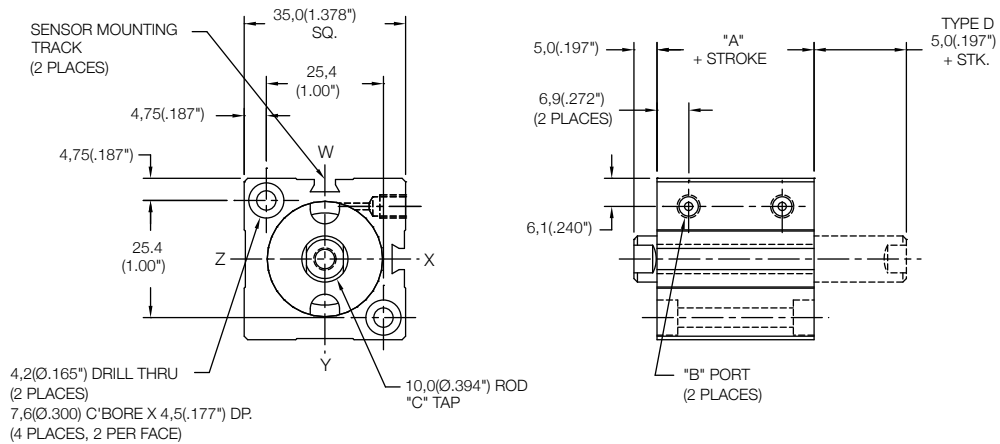

  - 25 X         M -      

MODEL    BORE    STROKE    TYPE    MOUNTING    MAGNETIC    OPTIONS

LS  
LE  
LH

5mm - 100mm STROKE (SEE STROKE RANGE)

BLANK - NO CODE, DOUBLE ACTING, SINGLE ROD  
 D - DOUBLE ACTING, DOUBLE ROD  
 S - SINGLE ACTING, SPRING RETRACT  
 R - SINGLE ACTING, SPRING EXTEND

MT - THRU MOUNT  
 MF - FRONT MOUNT  
 MR - REAR MOUNT  
 MB - BOTH END MOUNTS  
 FF - FRONT FLANGE  
 FR - REAR FLANGE (FOR FLANGES SEE PAGE 92)  
 PR - REAR PIVOT  
 PL - LONG PIVOT (FOR PIVOTS SEE PAGE 94)

SENSORS SOLD SEPARATELY  
 SKS, SKP, SCS, SCP - SOLID STATE LIMIT SENSORS (SEE PAGE 88)

EM - INCH THREADS & PORT OPTIONS  
 HS - HIGH TEMPERATURE SEALS OPTION: AVAILABLE ON LE AND LH MODELS ONLY (SEE PAGE 97)  
 PE - PORT ENLARGEMENT (AVAILABLE W/ "EM" OPTION ONLY = 1/8-27 NPT PORTS)  
 RE - ROD EYE (SEE PAGE 96)  
 RS - MALE STUD FOR ROD END (SEE PAGE 96)  
 RF, RH, RN, RT, RV, RY - ROD EXTENSIONS (SEE PAGE 96)  
 SH - HYDRAULIC OPTION (35 BAR 500 PSI) (SEE PAGE 97)  
 UB, UF, UR - URETHANE SHOCK PAD OPTION (SEE PAGE 97)

### Magnetic Side Mount Cylinder "MS"

MODEL	TYPE	STANDARD STROKES	"A"	PISTON AREA
LS	...D	5mm - 15mm	24,0(0.95")	PUSH 4,91 cm <sup>2</sup> (0.76 in <sup>2</sup> )
LE	-	5mm - 10mm	29,0(1.14")	
LH	...D	5mm	34,0(1.34")	PULL 4,12 cm <sup>2</sup> (0.64 in <sup>2</sup> )

	Standard Threads	"EM" Option
"B"	M5X0,8	#10-32
"C"	M5X0,8	#10-32
"D"	M5X0,8	#10-32

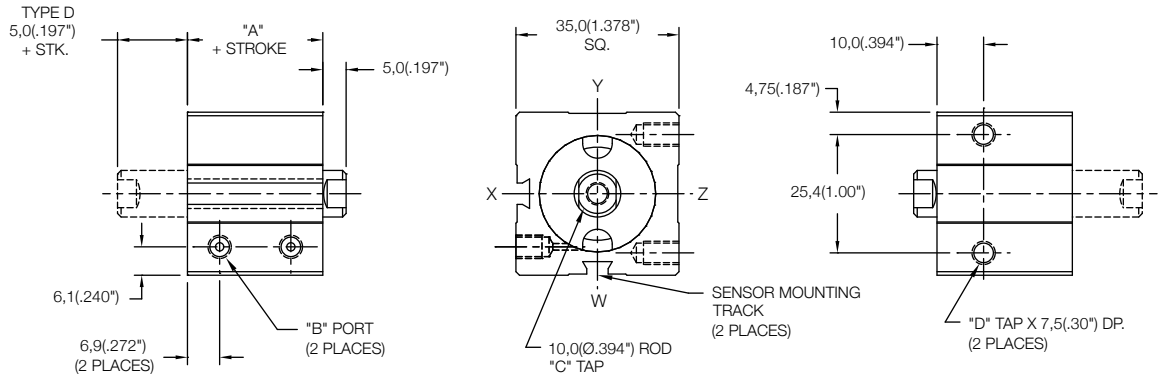

### Magnetic Side Mount Cylinder "MS"

MODEL	TYPE	STANDARD STROKES	"A"	PISTON AREA
LS	...D	20mm - 100mm	24,0(0.95")	PUSH 4,91 cm <sup>2</sup> (0.76 in <sup>2</sup> )
LE	-	15mm - 100mm	29,0(1.14")	
LH	...D	10mm - 100mm	34,0(1.34")	PULL 4,12 cm <sup>2</sup> (0.64 in <sup>2</sup> )
LS	S,R	5mm - 25mm	39,0(1.54")	
LS	S,R	26mm - 50mm	44,0(1.74")	

	Standard Threads	"EM" Option
"B"	M5X0,8	#10-32
"C"	M5X0,8	#10-32
"D"	M5X0,8	#10-32

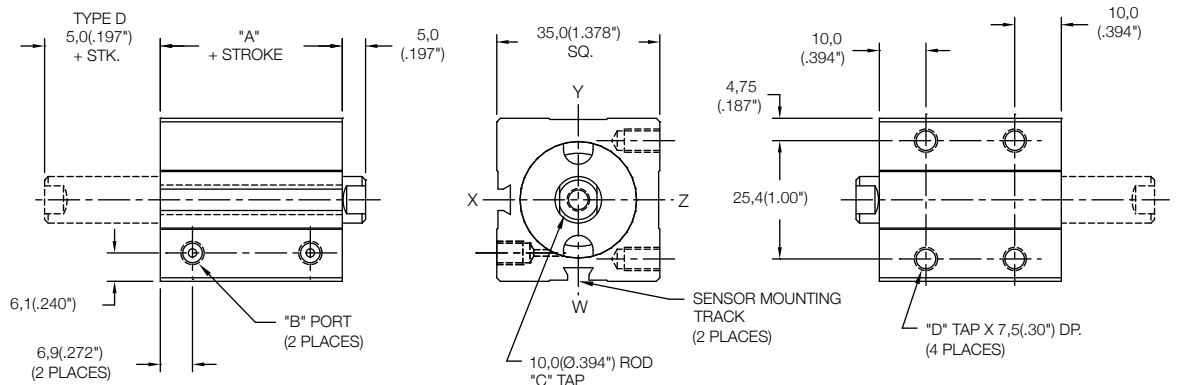

MODEL - 25 X STROKE TYPE MOUNTING MAGNETIC - OPTIONS

MODEL: LS, LE, LH  
 BORE: 25mm  
 STROKE: 5mm - 100mm (SEE STROKE RANGE)  
 TYPE: BLANK - NO CODE, DOUBLE ACTING, SINGLE ROD; D - DOUBLE ACTING, DOUBLE ROD; S - SINGLE ACTING, SPRING RETRACT; R - SINGLE ACTING, SPRING EXTEND  
 MOUNTING: MS - SIDE MOUNT; FE - FLANGE ON END; FS - FLANGE ON SIDE (SEE PAGE 93)  
 MAGNETIC: M  
 OPTIONS: EM - INCH THREADS & PORT OPTIONS; HS - HIGH TEMPERATURE SEALS OPTION: AVAILABLE ON LE AND LH MODELS ONLY (SEE PAGE 97); PE - PORT ENLARGEMENT (AVAILABLE W/ "EM" OPTION ONLY = 1/8-27 NPT PORTS); RE - ROD EYE (SEE PAGE 96); RS - MALE STUD FOR ROD END (SEE PAGE 96); RF, RH, RN, RT, RV, RY - ROD EXTENSIONS (SEE PAGE 96); SH - HYDRAULIC OPTION (35 BAR 500 PSI) (SEE PAGE 97); UB, UF, UR - URETHANE SHOCK PAD OPTION (SEE PAGE 97)

SENSORS SOLD SEPARATELY  
 SKS, SKP, SCS, SCP - SOLID STATE  
 LIMIT SENSORS (SEE PAGE 88)

### Non Magnetic Side Mount Cylinder "MS"

MODEL	TYPE	STANDARD STROKES	"A"	PISTON AREA
LS	_D	10mm - 20mm	19,0(0.75")	PUSH 4,91 cm <sup>2</sup> (0.76 in <sup>2</sup> )
LE	-	5mm - 15mm	24,0(0.95")	
LH	_D	5mm - 10mm	29,0(1.14")	PULL 4,12 cm <sup>2</sup> (0.64 in <sup>2</sup> )
LS	S,R	5mm	34,0(1.34")	

	Standard Threads	"EM" Option
"B"	M5X0,8	#10-32
"C"	M5X0,8	#10-32
"D"	M5X0,8	#10-32

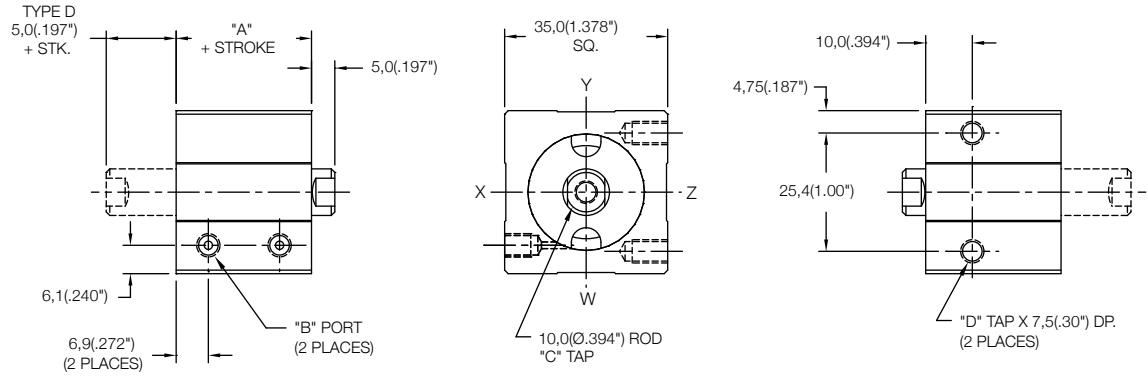

### Non Magnetic Side Mount Cylinder "MS"

MODEL	TYPE	STANDARD STROKES	"A"	PISTON AREA
LS	_D	25mm - 100mm	19,0(0.75")	PUSH 4,91 cm <sup>2</sup> (0.76 in <sup>2</sup> )
LE	-	20mm - 100mm	24,0(0.95")	
LH	_D	15mm - 100mm	29,0(1.14")	PULL 4,12 cm <sup>2</sup> (0.64 in <sup>2</sup> )
LS	S,R	10mm - 25mm	34,0(1.34")	
LS	S,R	26mm - 50mm	39,0(1.54")	

	Standard Threads	"EM" Option
"B"	M5X0,8	#10-32
"C"	M5X0,8	#10-32
"D"	M5X0,8	#10-32

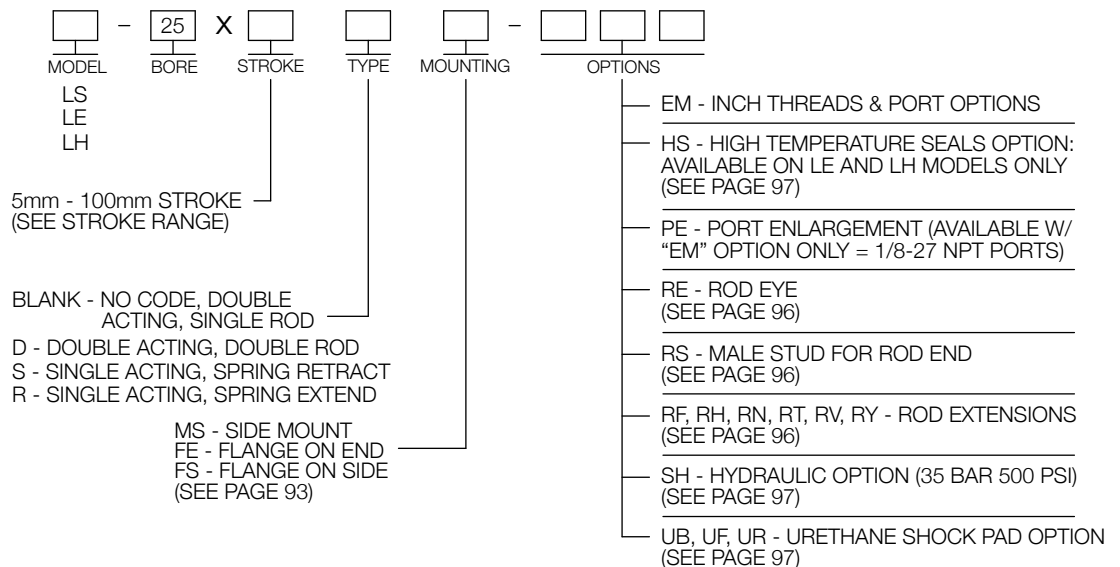
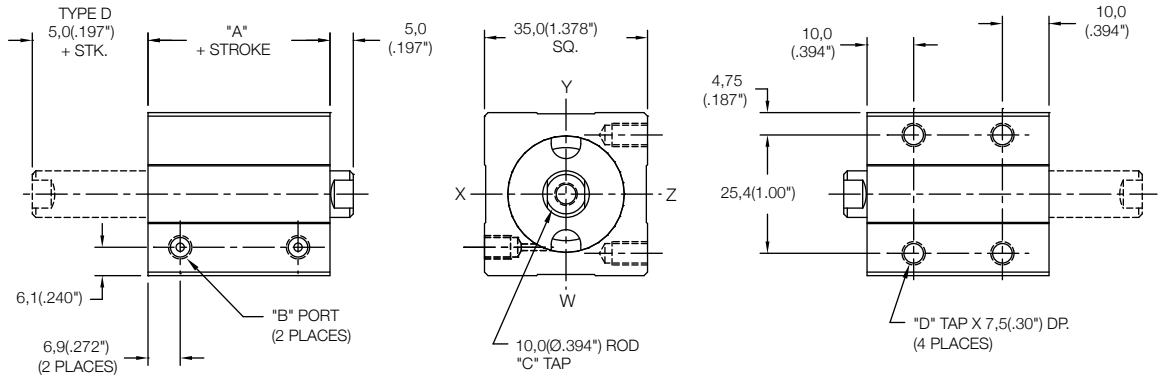

### Non Magnetic Front Mount Cylinder "MF"

MODEL	TYPE	STANDARD STROKES	"A"	PISTON AREA
LS	_D	6,35mm - 101,6mm	19,05(.75")	PUSH 6,41 cm <sup>2</sup> (1.0 in <sup>2</sup> )
LE	_	6,35mm - 101,6mm	25,4(1.00")	
LH	_D	6,35mm - 101,6mm	31,75(1.25")	PULL 5,28 cm <sup>2</sup> (0.82 in <sup>2</sup> )
LS	S,R	6,35mm - 25,4mm	31,75(1.25")	
LS	S,R	31,8mm - 50,8mm	38,1(1.50")	

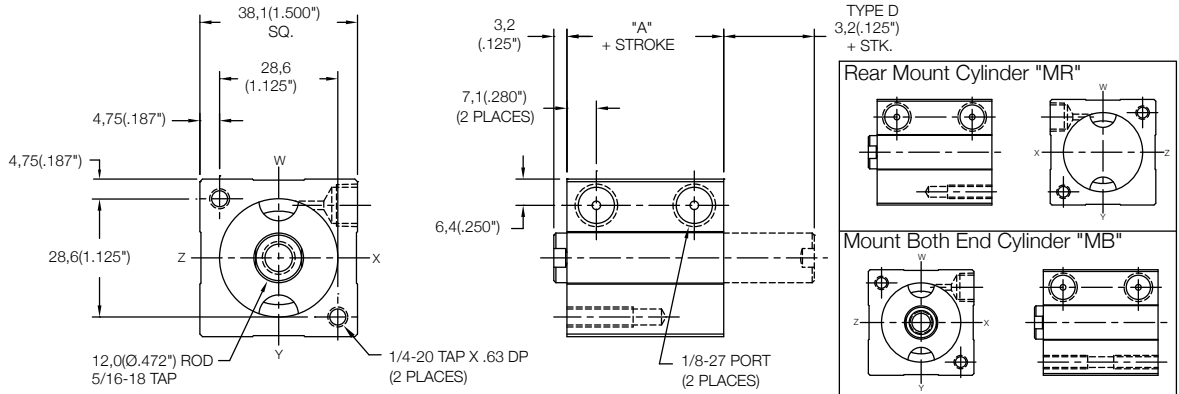

### Non Magnetic Thru Mount Cylinder "MT"

MODEL	TYPE	STANDARD STROKES	"A"	PISTON AREA
LS	_D	6,35mm - 25,4mm	19,05(.75")	PUSH 6,41 cm <sup>2</sup> (1.0 in <sup>2</sup> )
LE	_	6,35mm - 19,05mm	25,4(1.00")	
LH	_D	6,35mm - 12,7mm	31,75(1.25")	PULL 5,28 cm <sup>2</sup> (0.82 in <sup>2</sup> )
LS	S,R	6,35mm - 12,7mm	31,75(1.25")	

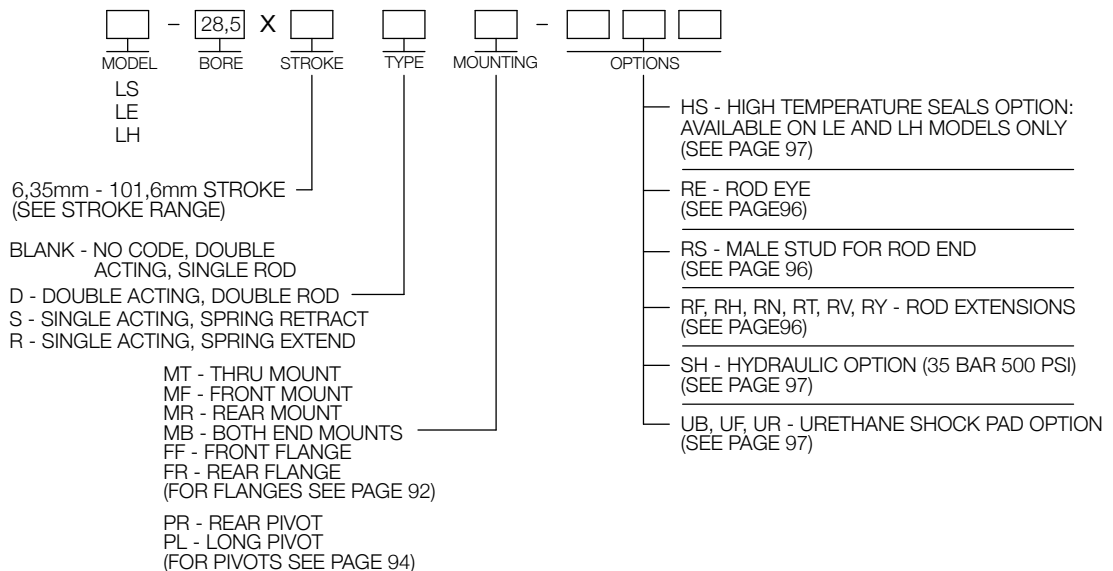
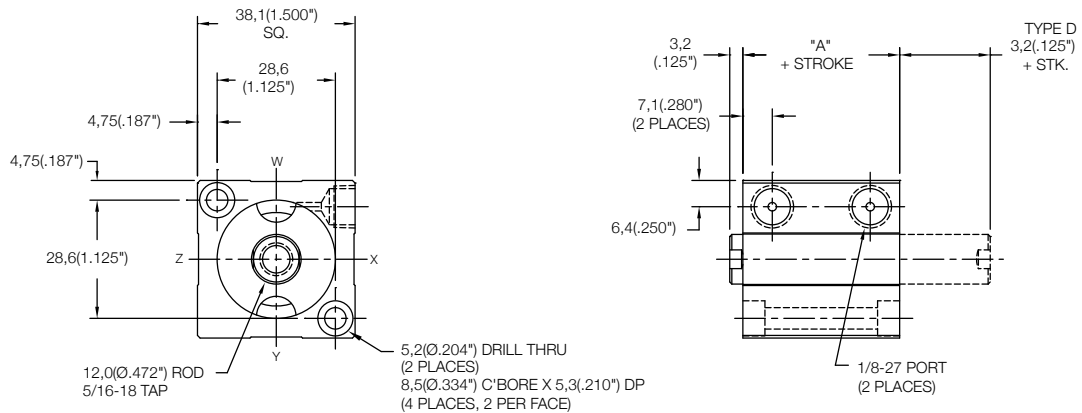

### Magnetic Front Mount Cylinder "MF"

MODEL	TYPE	STANDARD STROKES	"A"	PISTON AREA
LS	...D	6,35mm - 101,6mm	25,4(1.00")	PUSH 6,41 cm <sup>2</sup> (1.0 in <sup>2</sup> )
LE	-	6,35mm - 101,6mm	31,75(1.25")	
LH	...D	6,35mm - 101,6mm	38,1(1.50")	
LS	S,R	6,35mm - 25,4mm	38,1(1.50")	PULL 5,28 cm <sup>2</sup> (0.82 in <sup>2</sup> )
LS	S,R	31,8mm - 50,8mm	44,45(1.75")	

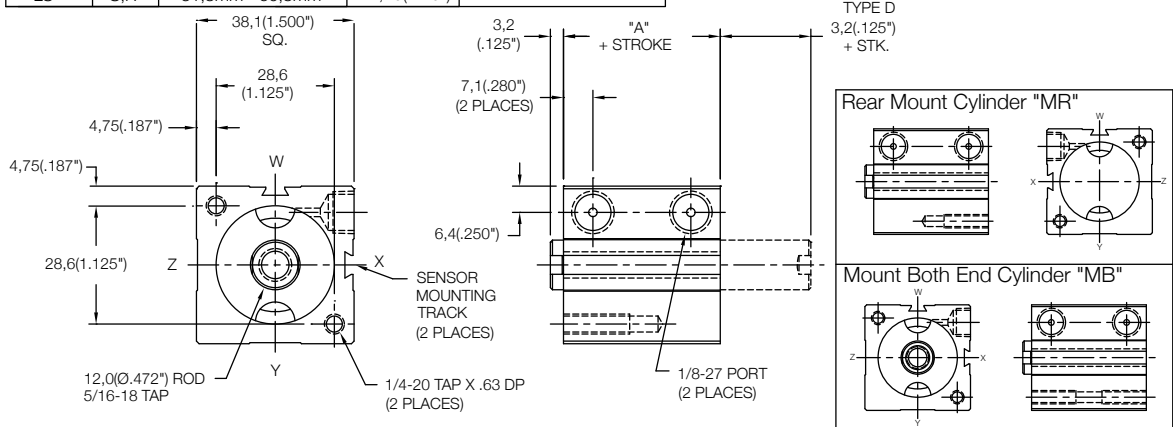

### Magnetic Thru Mount Cylinder "MT"

MODEL	TYPE	STANDARD STROKES	"A"	PISTON AREA
LS	...D	6,35mm - 19,05mm	25,4(1.00")	PUSH 6,41 cm <sup>2</sup> (1.0 in <sup>2</sup> )
LE	-	6,35mm - 12,7mm	31,75(1.25")	
LH	...D	6,35mm	38,1(1.50")	
LS	S,R	6,35mm	38,1(1.50")	PULL 5,28 cm <sup>2</sup> (0.82 in <sup>2</sup> )

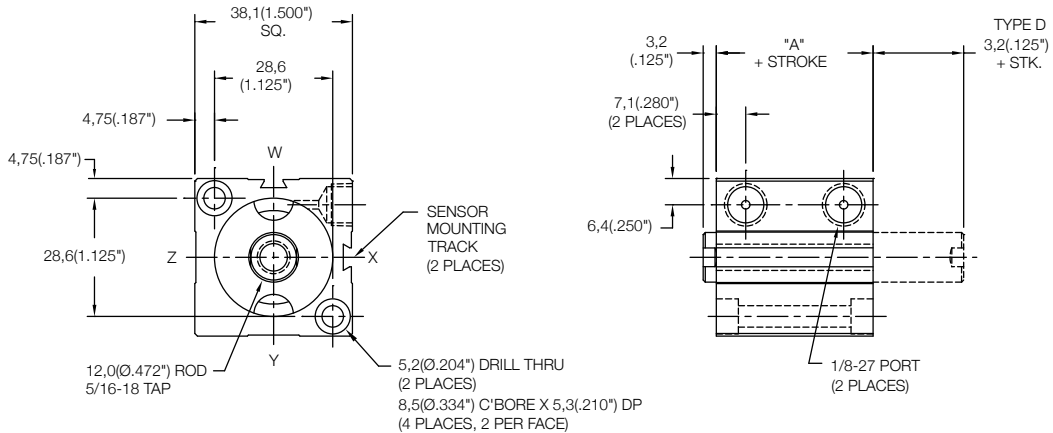

<div style="border: 1px solid black; width: 20px; height: 10px; margin: 0 auto;"></div> MODEL LS LE LH	- <b>28,5</b> X <div style="border: 1px solid black; width: 20px; height: 10px; margin: 0 auto;"></div> BORE STROKE	<div style="border: 1px solid black; width: 20px; height: 10px; margin: 0 auto;"></div> TYPE	<div style="border: 1px solid black; width: 20px; height: 10px; margin: 0 auto;"></div> MOUNTING	<div style="border: 1px solid black; width: 20px; height: 10px; margin: 0 auto;"></div> MAGNETIC	<div style="border: 1px solid black; width: 20px; height: 10px; margin: 0 auto;"></div> - <div style="border: 1px solid black; width: 20px; height: 10px; margin: 0 auto;"></div> OPTIONS	SENSORS SOLD SEPARATELY SKS, SKP, SCS, SCP - SOLID STATE LIMIT SENSORS (SEE PAGE 88)
6,35mm - 101,6mm STROKE (SEE STROKE RANGE)		BLANK - NO CODE, DOUBLE ACTING, SINGLE ROD		D - DOUBLE ACTING, DOUBLE ROD S - SINGLE ACTING, SPRING RETRACT R - SINGLE ACTING, SPRING EXTEND		HS - HIGH TEMPERATURE SEALS OPTION: AVAILABLE ON LE AND LH MODELS ONLY (SEE PAGE 97)
MT - THRU MOUNT MF - FRONT MOUNT MR - REAR MOUNT MB - BOTH END MOUNTS		FF - FRONT FLANGE FR - REAR FLANGE (FOR FLANGES SEE PAGE 92)		RE - ROD EYE (SEE PAGE 96)		
PR - REAR PIVOT PL - LONG PIVOT (FOR PIVOTS SEE PAGE 94)		RF, RH, RN, RT, RV, RY - ROD EXTENSIONS (SEE PAGE 96)		SH - HYDRAULIC OPTION (35 BAR 500 PSI) (SEE PAGE 97)		
				UB, UF, UR - URETHANE SHOCK PAD OPTION (SEE PAGE 97)		

### Magnetic Side Mount Cylinder "MS"

MODEL	TYPE	STANDARD STROKES	"A"	PISTON AREA
LS	_,D	6,35mm - 12,7mm	25,4(1.00")	PUSH 6,41 cm <sup>2</sup> (1.0 in <sup>2</sup> )
LE	_	6,35mm	31,75(1.25")	PULL 5,28 cm <sup>2</sup> (0.82 in <sup>2</sup> )

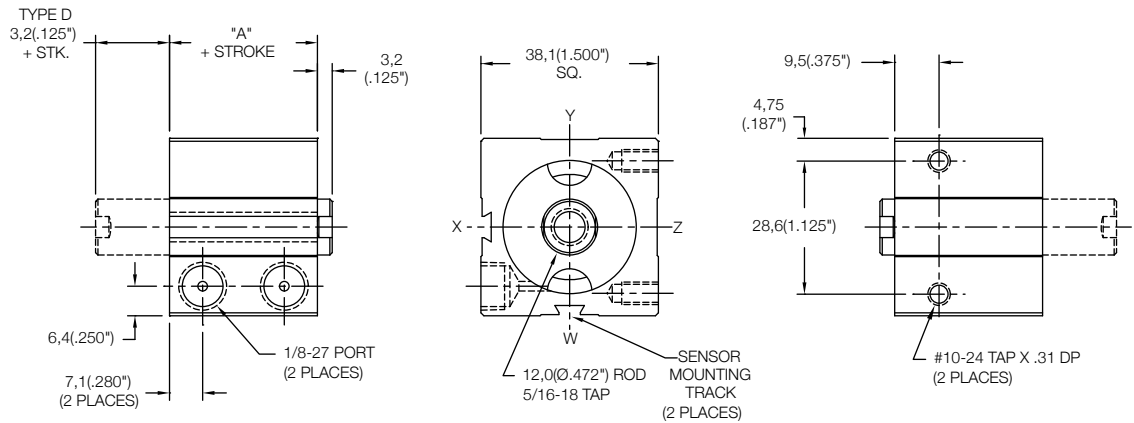

### Magnetic Side Mount Cylinder "MS"

MODEL	TYPE	STANDARD STROKES	"A"	PISTON AREA
LS	_,D	19,05mm - 101,6mm	25,4(1.00")	PUSH 6,41 cm <sup>2</sup> (1.0 in <sup>2</sup> )
LE	_	12,7mm - 101,6mm	31,75(1.25")	PULL 5,28 cm <sup>2</sup> (0.82 in <sup>2</sup> )
LH	_,D	6,35mm - 101,6mm	38,1(1.50")	PULL 5,28 cm <sup>2</sup> (0.82 in <sup>2</sup> )
LS	S,R	6,35mm - 25,4mm	38,1(1.50")	
LS	S,R	31,8mm - 50,8mm	44,45(1.75")	

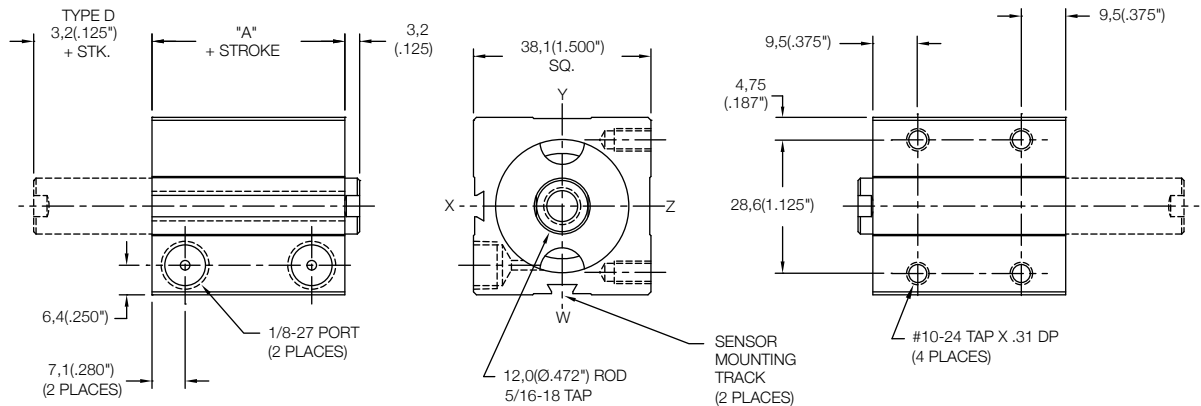

<p>MODEL</p> <p>LS LE LH</p> <p>6.35mm - 101.6mm STROKE (SEE STROKE RANGE)</p> <p>BLANK - NO CODE, DOUBLE ACTING, SINGLE ROD</p> <p>D - DOUBLE ACTING, DOUBLE ROD</p> <p>S - SINGLE ACTING, SPRING RETRACT</p> <p>R - SINGLE ACTING, SPRING EXTEND</p> <p>MS - SIDE MOUNT</p> <p>FE - FLANGE ON END</p> <p>FS - FLANGE ON SIDE (SEE PAGE 93)</p>	<p>28.5</p> <p>BORE</p> <p>X</p> <p>STROKE</p> <p>TYPE</p> <p>MOUNTING</p> <p>MAGNETIC</p> <p>M</p> <p>OPTIONS</p>	<p>SENSORS SOLD SEPARATELY SKS, SKP, SCS, SCP - SOLID STATE LIMIT SENSORS (SEE PAGE 88)</p> <p>HS - HIGH TEMPERATURE SEALS OPTION: AVAILABLE ON LE AND LH MODELS ONLY (SEE PAGE 97)</p> <p>RE - ROD EYE (SEE PAGE 96)</p> <p>RS - MALE STUD FOR ROD END (SEE PAGE 96)</p> <p>RF, RH, RN, RT, RV, RY - ROD EXTENSIONS (SEE PAGE 96)</p> <p>SH - HYDRAULIC OPTION (35 BAR 500 PSI) (SEE PAGE 97)</p> <p>UB, UF, UR - URETHANE SHOCK PAD OPTION (SEE PAGE 97)</p>
--	--	--

## Non Magnetic Side Mount Cylinder "MS"

MODEL	TYPE	STANDARD STROKES	"A"	PISTON AREA
LS	..D	6,35mm - 19,05mm	19,05(0.75")	PUSH 6,41 cm <sup>2</sup> (1.0 in <sup>2</sup> )
LE	-	6,35mm - 12,7mm	25,4(1.00")	
LH	..D	6,35mm	31,75(1.25")	PULL 5,28 cm <sup>2</sup> (0.82 in <sup>2</sup> )
LS	S,R	6,35mm	31,75(1.25")	

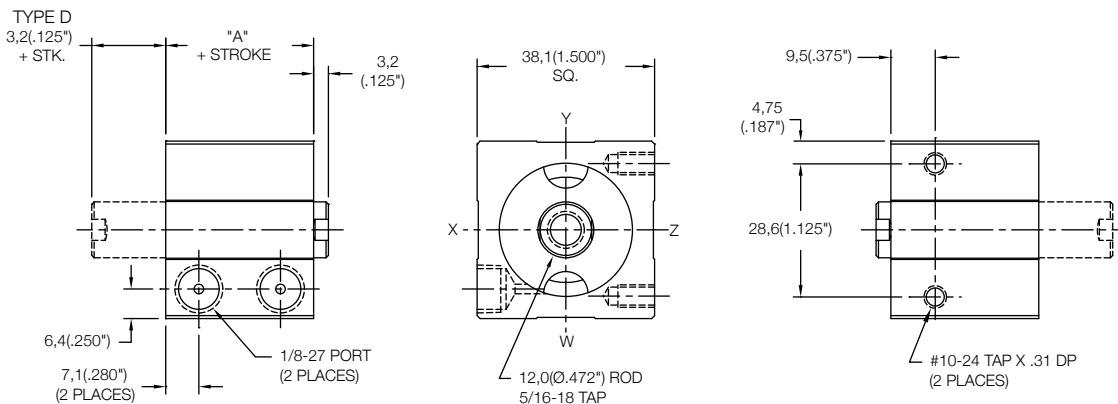

## Non Magnetic Side Mount Cylinder "MS"

MODEL	TYPE	STANDARD STROKES	"A"	PISTON AREA
LS	..D	25,4mm - 101,6mm	19,05(.75")	PUSH 6,41 cm <sup>2</sup> (1.0 in <sup>2</sup> )
LE	-	19,05mm - 101,6mm	25,4(1.00")	
LH	..D	12,7mm - 101,6mm	31,75(1.25")	PULL 5,28 cm <sup>2</sup> (0.82 in <sup>2</sup> )
LS	S,R	12,7mm - 25,4mm	31,75(1.25")	
LS	S,R	31,8mm - 60,8mm	38,1(1.50")	

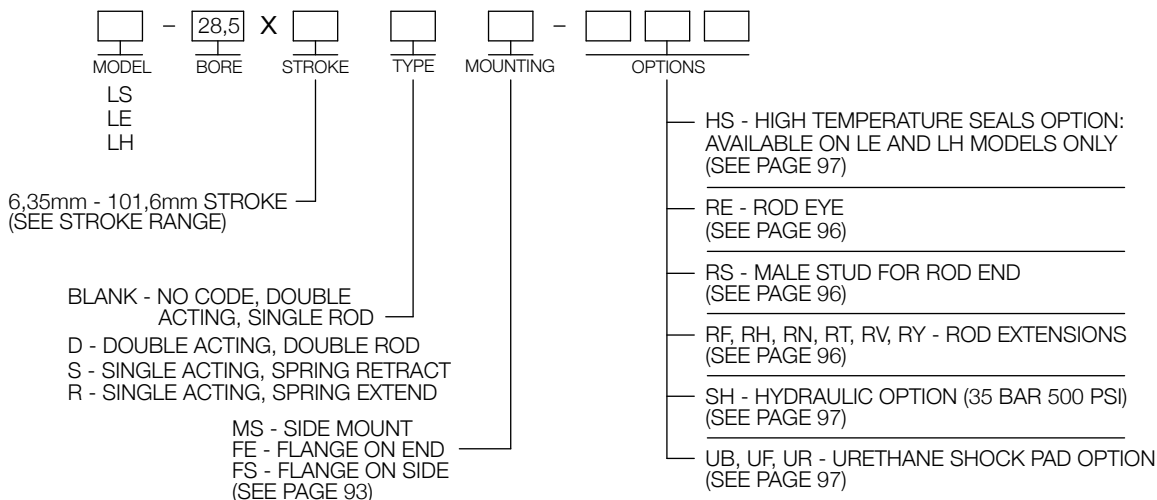
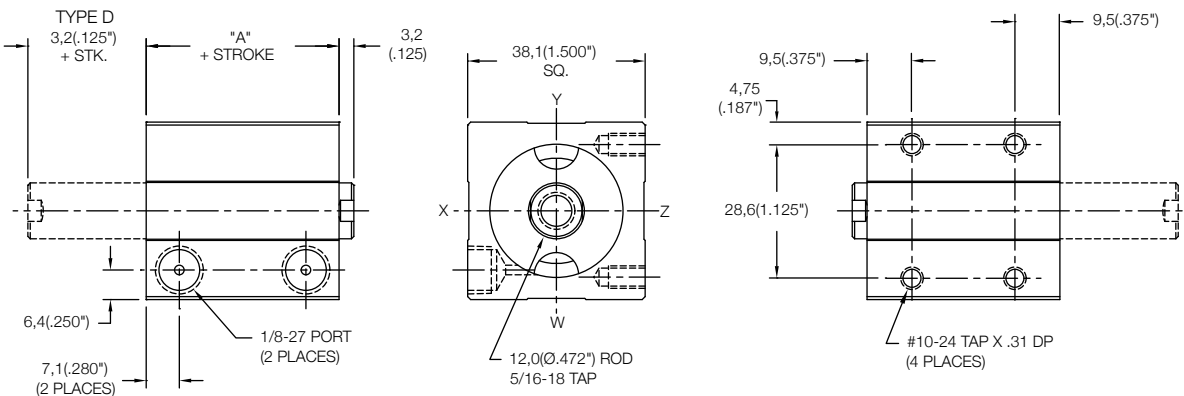

## Non Magnetic Front Mount Cylinder "MF"

MODEL	TYPE	STANDARD STROKES	"A"	PISTON AREA
LS	_,D	10mm - 100mm	22,5(0.89")	PUSH 8,04 cm <sup>2</sup> (1.25 in <sup>2</sup> )
LE	_	5mm - 100mm	27,5(1.08")	
LH	_,D	5mm - 100mm	32,5(1.28")	PULL 6,91 cm <sup>2</sup> (1.07 in <sup>2</sup> )
LS	S,R	5mm - 25mm	37,5(1.48")	
LS	S,R	26mm - 50mm	42,5(1.68")	

	Standard Threads	"EM" Option
"B"	G1/8 PORT	1/8-27
"C"	M6X1,0	1/4-20
"D"	M6X1,0	1/4-20

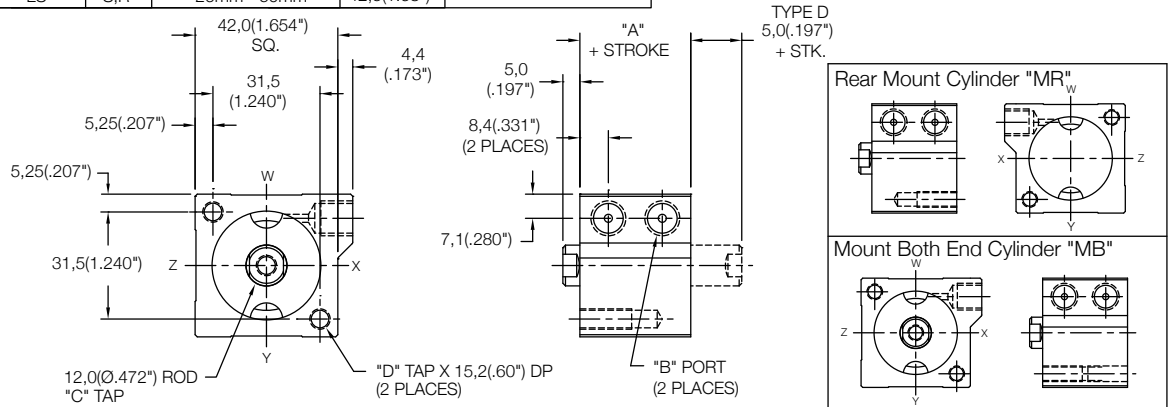

## Non Magnetic Thru Mount Cylinder "MT"

MODEL	TYPE	STANDARD STROKES	"A"	PISTON AREA
LS	_,D	10mm - 25mm	22,5(0.89")	PUSH 8,04 cm <sup>2</sup> (1.25 in <sup>2</sup> )
LE	_	5mm - 20mm	27,5(1.08")	
LH	_,D	5mm - 15mm	32,5(1.28")	PULL 6,91 cm <sup>2</sup> (1.07 in <sup>2</sup> )
LS	S,R	5mm - 10mm	37,5(1.48")	

	Standard Threads	"EM" Option
"B"	G1/8 PORT	1/8-27
"C"	M6X1,0	1/4-20

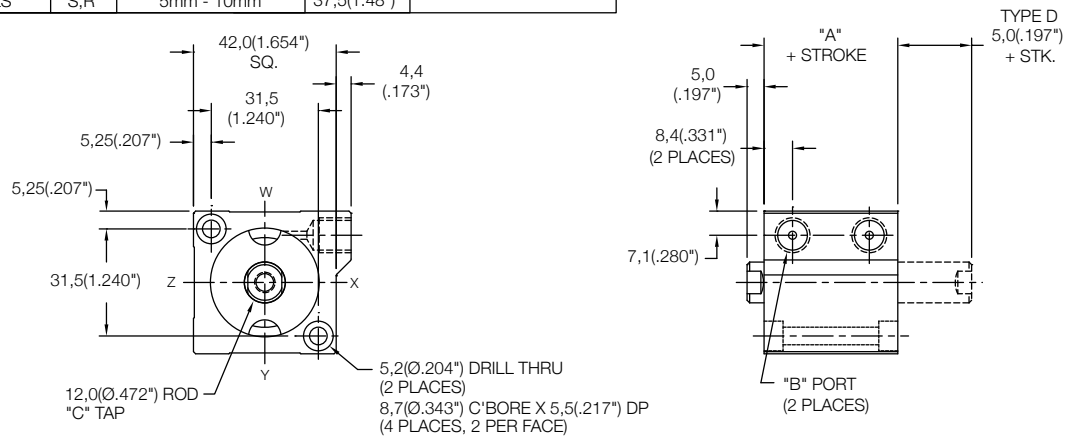

   - 32 X          -         

MODEL    BORE    STROKE    TYPE    MOUNTING    OPTIONS

LS  
LE  
LH

5mm - 100mm STROKE  
(SEE STROKE RANGE)

BLANK - NO CODE, DOUBLE ACTING, SINGLE ROD  
 D - DOUBLE ACTING, DOUBLE ROD  
 S - SINGLE ACTING, SPRING RETRACT  
 R - SINGLE ACTING, SPRING EXTEND

MT - THRU MOUNT  
 MF - FRONT MOUNT  
 MR - REAR MOUNT  
 MB - BOTH END MOUNTS  
 FF - FRONT FLANGE  
 FR - REAR FLANGE  
 (FOR FLANGES SEE PAGE 92)

PR - REAR PIVOT  
 PL - LONG PIVOT  
 (FOR PIVOTS SEE PAGE 94)

EM - INCH THREADS & PORT OPTIONS  
 HS - HIGH TEMPERATURE SEALS OPTION:  
 AVAILABLE ON LE AND LH MODELS ONLY  
 (SEE PAGE 97)  
 RE - ROD EYE  
 (SEE PAGE 96)  
 RS - MALE STUD FOR ROD END  
 (SEE PAGE 96)  
 RF, RH, RN, RT, RV, RY - ROD EXTENSIONS  
 (SEE PAGE 96)  
 SH - HYDRAULIC OPTION (35 BAR 500 PSI)  
 (SEE PAGE 97)  
 UB, UF, UR - URETHANE SHOCK PAD OPTION  
 (SEE PAGE 97)



## Magnetic Front Mount Cylinder "MF"

MODEL	TYPE	STANDARD STROKES	"A"	PISTON AREA
LS	...D	5mm - 100mm	27,5(1.08")	PUSH 8,04 cm <sup>2</sup> (1.25 in <sup>2</sup> )
LE	-	5mm - 100mm	32,5(1.28")	
LH	...D	5mm - 100mm	37,5(1.48")	PULL 6,91 cm <sup>2</sup> (1.07 in <sup>2</sup> )
LS	S,R	5mm - 25mm	42,5(1.68")	
LS	S,R	26mm - 50mm	47,5(1.88")	

	Standard Threads	"EM" Option
"B"	G1/8 PORT	1/8-27
"C"	M6X1,0	1/4-20
"D"	M6X1,0	1/4-20

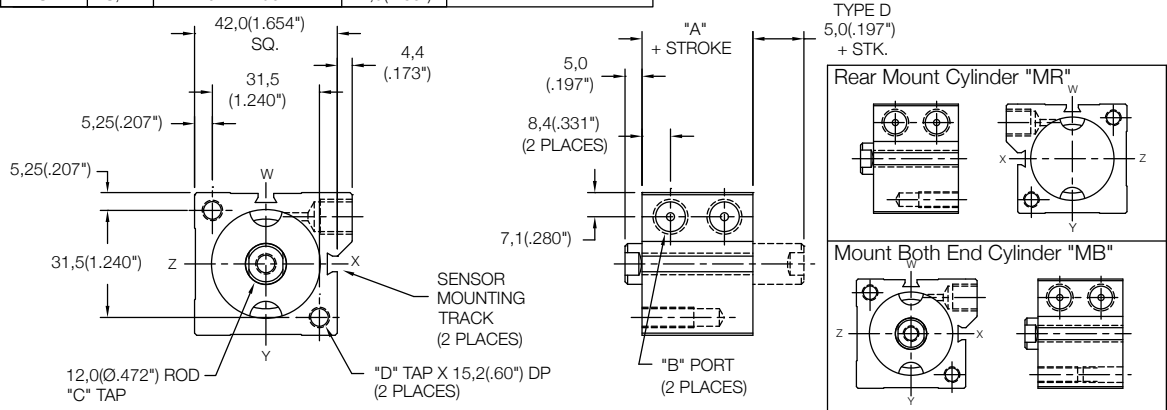

## Magnetic Thru Mount Cylinder "MT"

MODEL	TYPE	STANDARD STROKES	"A"	PISTON AREA
LS	...D	5mm - 20mm	27,5(1.08")	PUSH 8,04 cm <sup>2</sup> (1.25 in <sup>2</sup> )
LE	-	5mm - 15mm	32,5(1.28")	
LH	...D	5mm - 10mm	37,5(1.48")	PULL 6,91 cm <sup>2</sup> (1.07 in <sup>2</sup> )
LS	S,R	5mm	42,5(1.68")	

	Standard Threads	"EM" Option
"B"	G1/8 PORT	1/8-27
"C"	M6X1,0	1/4-20

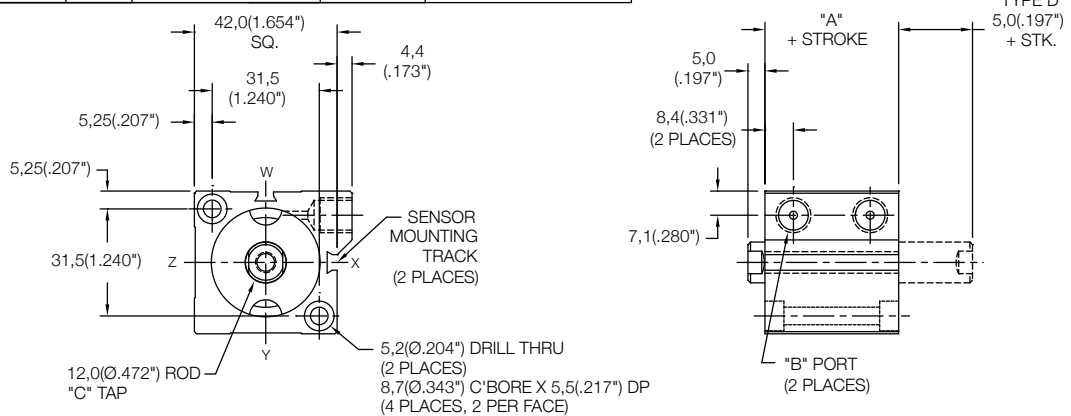

MODEL	-	32	X	STROKE	TYPE	MOUNTING	MAGNETIC	M	-	OPTIONS
LS LE LH				5mm - 100mm STROKE (SEE STROKE RANGE)						EM - INCH THREADS & PORT OPTIONS
				BLANK - NO CODE, DOUBLE ACTING, SINGLE ROD						HS - HIGH TEMPERATURE SEALS OPTION: AVAILABLE ON LE AND LH MODELS ONLY (SEE PAGE 97)
				D - DOUBLE ACTING, DOUBLE ROD						RE - ROD EYE (SEE PAGE 96)
				S - SINGLE ACTING, SPRING RETRACT						RS - MALE STUD FOR ROD END (SEE PAGE 96)
				R - SINGLE ACTING, SPRING EXTEND						RF, RH, RN, RT, RV, RY - ROD EXTENSIONS (SEE PAGE 96)
				MT - THRU MOUNT						SH - HYDRAULIC OPTION (35 BAR 500 PSI) (SEE PAGE 97)
				MF - FRONT MOUNT						UB, UF, UR - URETHANE SHOCK PAD OPTION (SEE PAGE 97)
				MR - REAR MOUNT						
				MB - BOTH END MOUNTS						
				FF - FRONT FLANGE						
				FR - REAR FLANGE (FOR FLANGES SEE PAGE 92)						
				PR - REAR PIVOT						
				PL - LONG PIVOT (FOR PIVOTS SEE PAGE 94)						

SENSORS SOLD SEPARATELY  
SKS, SKP, SCS, SCP - SOLID STATE  
LIMIT SENSORS (SEE PAGE 88)

## Magnetic Side Mount Cylinder "MS"

MODEL	TYPE	STANDARD STROKES	"A"	PISTON AREA
LS	..D	5mm - 15mm	27,5(1.08")	PUSH 8,04 cm <sup>2</sup> (1.25 in <sup>2</sup> )
LE	-	5mm - 10mm	32,5(1.28")	
LH	..D	5mm	37,5(1.48")	PULL 6,91 cm <sup>2</sup> (1.07 in <sup>2</sup> )

	Standard Threads	"EM" Option
"B"	G1/8 PORT	1/8-27
"C"	M6X1,0	1/4-20
"D"	M5X0,8	#10-32

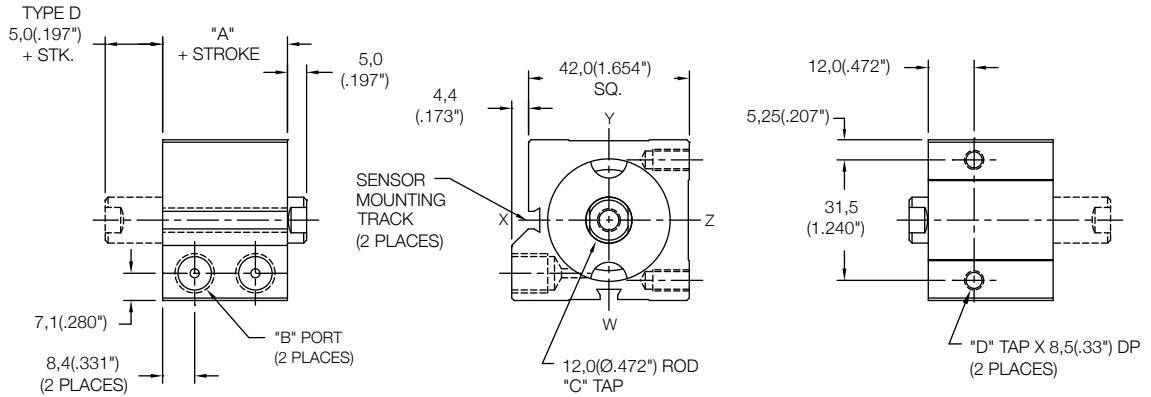

## Magnetic Side Mount Cylinder "MS"

MODEL	TYPE	STANDARD STROKES	"A"	PISTON AREA
LS	..D	20mm - 100mm	27,5(1.08")	PUSH 8,04 cm <sup>2</sup> (1.25 in <sup>2</sup> )
LE	-	15mm - 100mm	32,5(1.28")	
LH	..D	10mm - 100mm	37,5(1.48")	PULL 6,91 cm <sup>2</sup> (1.07 in <sup>2</sup> )
LS	S,R	5mm - 25mm	42,5(1.68")	
LS	S,R	26mm - 50mm	47,5(1.87")	

	Standard Threads	"EM" Option
"B"	G1/8 PORT	1/8-27
"C"	M6X1,0	1/4-20
"D"	M5X0,8	#10-32

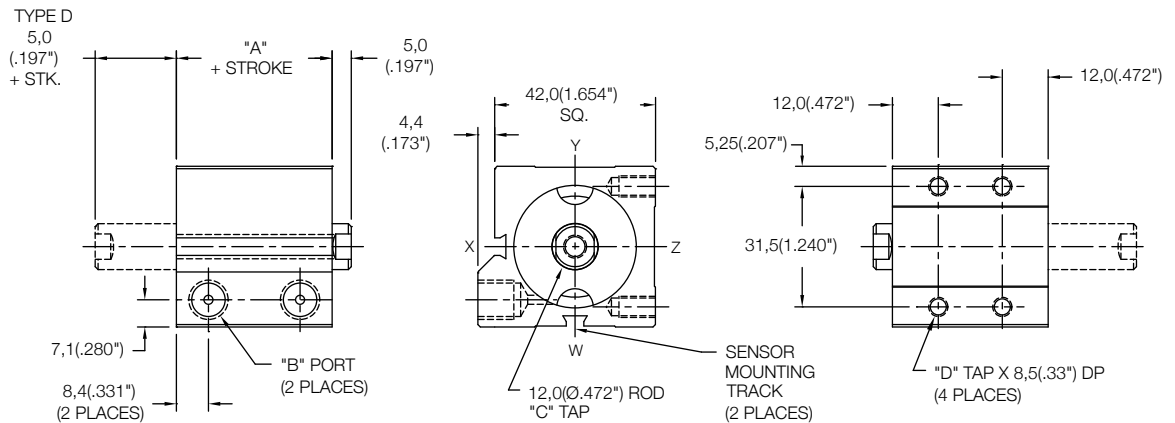

<table border="1"> <tr> <td>MODEL</td> <td>-</td> <td>32</td> <td>X</td> <td>STROKE</td> <td>TYPE</td> <td>MOUNTING</td> <td>MAGNETIC</td> <td>M</td> <td>-</td> <td>OPTIONS</td> </tr> <tr> <td>LS LE LH</td> <td></td> <td></td> <td></td> <td></td> <td></td> <td></td> <td></td> <td></td> <td></td> <td></td> </tr> </table> <p>5mm - 100mm STROKE (SEE STROKE RANGE)</p> <p>BLANK - NO CODE, DOUBLE ACTING, SINGLE ROD</p> <p>D - DOUBLE ACTING, DOUBLE ROD</p> <p>S - SINGLE ACTING, SPRING RETRACT</p> <p>R - SINGLE ACTING, SPRING EXTEND</p> <p>MS - SIDE MOUNT FE - FLANGE ON END FS - FLANGE ON SIDE (SEE PAGE 93)</p>	MODEL	-	32	X	STROKE	TYPE	MOUNTING	MAGNETIC	M	-	OPTIONS	LS LE LH											<p>SENSORS SOLD SEPARATELY SKS, SKP, SCS, SCP - SOLID STATE LIMIT SENSORS (SEE PAGE 88)</p> <p>EM - INCH THREADS &amp; PORT OPTIONS</p> <p>HS - HIGH TEMPERATURE SEALS OPTION: AVAILABLE ON LE AND LH MODELS ONLY (SEE PAGE 97)</p> <p>RE - ROD EYE (SEE PAGE 96)</p> <p>RS - MALE STUD FOR ROD END (SEE PAGE 96)</p> <p>RF, RH, RN, RT, RV, RY - ROD EXTENSIONS (SEE PAGE 96)</p> <p>SH - HYDRAULIC OPTION (35 BAR 500 PSI) (SEE PAGE 97)</p> <p>UB, UF, UR - URETHANE SHOCK PAD OPTION (SEE PAGE 97)</p>
MODEL	-	32	X	STROKE	TYPE	MOUNTING	MAGNETIC	M	-	OPTIONS													
LS LE LH																							

## Non Magnetic Side Mount Cylinder "MS"

MODEL	TYPE	STANDARD STROKES	"A"	PISTON AREA
LS	...D	10mm - 20mm	22,5(0.89")	PUSH 8,04 cm <sup>2</sup> (1.25 in <sup>2</sup> )
LE	-	5mm - 15mm	27,5(1.08")	
LH	...D	5mm - 10mm	32,5(1.28")	PULL 6,91 cm <sup>2</sup> (1.07 in <sup>2</sup> )
LS	S,R	5mm	37,5(1.48")	

	Standard Threads	"EM" Option
"B"	G1/8 PORT	1/8-27
"C"	M6X1,0	1/4-20
"D"	M5X0,8	#10-32

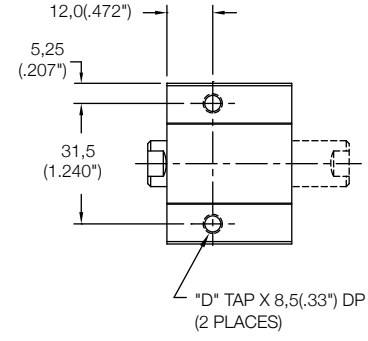
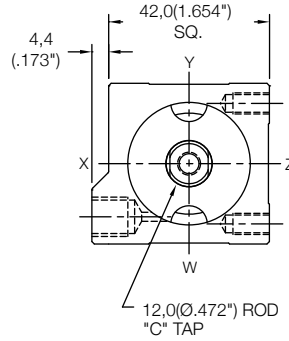
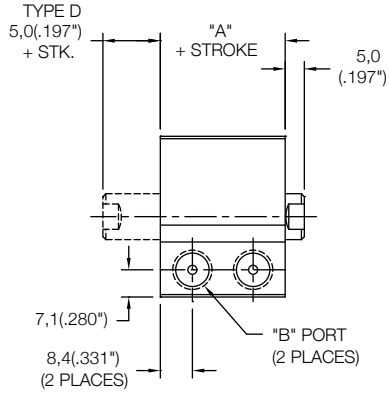

## Non Magnetic Side Mount Cylinder "MS"

MODEL	TYPE	STANDARD STROKES	"A"	PISTON AREA
LS	...D	25mm - 100mm	22,5(0.89")	PUSH 8,04 cm <sup>2</sup> (1.25 in <sup>2</sup> )
LE	-	20mm - 100mm	27,5(1.08")	
LH	...D	15mm - 100mm	32,5(1.28")	PULL 6,91 cm <sup>2</sup> (1.07 in <sup>2</sup> )
LS	S,R	10mm - 25mm	37,5(1.48")	
LS	S,R	26mm - 50mm	42,5(1.68")	

	Standard Threads	"EM" Option
"B"	G1/8 PORT	1/8-27
"C"	M6X1,0	1/4-20
"D"	M5X0,8	#10-32

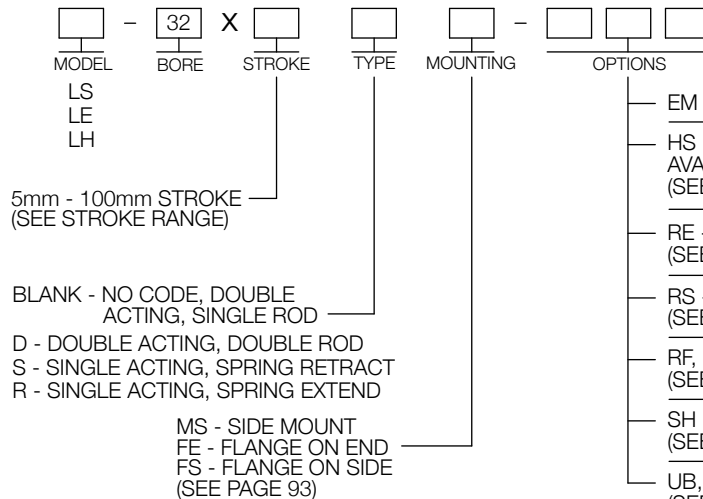
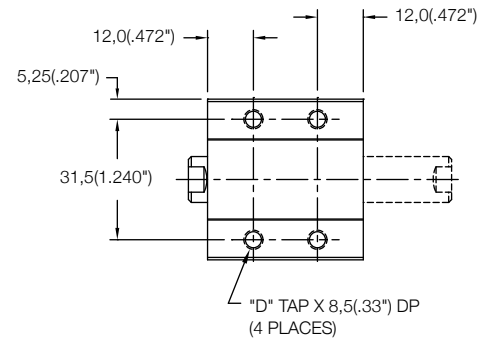
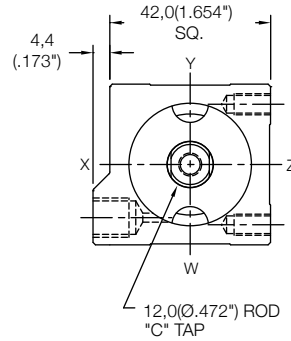
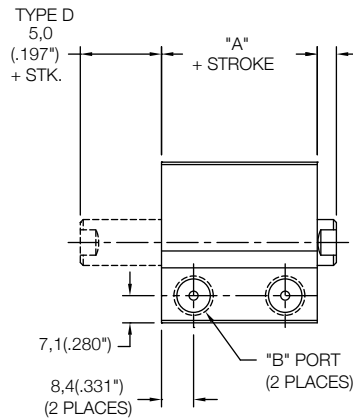

### Non Magnetic Front Mount Cylinder "MF"

MODEL	TYPE	STANDARD STROKES	"A"	PISTON AREA
LS	_,D	10mm - 100mm	25,0(0.98")	PUSH 12,56 cm <sup>2</sup> (1.95 in <sup>2</sup> )
LE	-	5mm - 100mm	35,0(1.38")	
LH	-	5mm - 100mm	40,0(1.58")	PULL 10,55 cm <sup>2</sup> (1.64 in <sup>2</sup> )
LH	D	5mm - 100mm	45,0(1.78")	
LS	S,R	5mm - 25mm	45,0(1.78")	
LS	S,R	26mm - 50mm	55,0(2.17")	

	Standard Threads	"EM" Option
"B"	G1/8 PORT	1/8-27
"C"	M8X1,25	5/16-18
"D"	M6X1,0	1/4-20

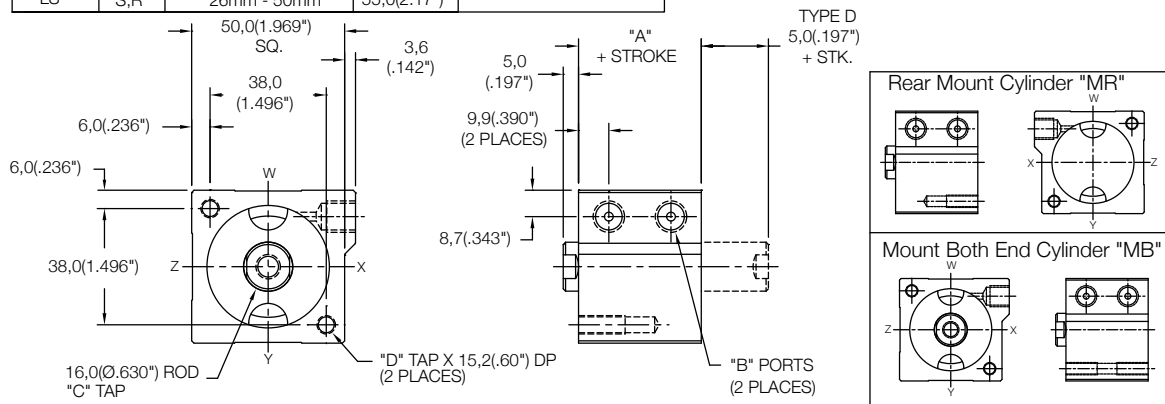

### Non Magnetic Thru Mount Cylinder "MT"

MODEL	TYPE	STANDARD STROKES	"A"	PISTON AREA
LS	_,D	10mm - 25mm	25,0(0.98")	PUSH 12,56 cm <sup>2</sup> (1.95 in <sup>2</sup> )
LE	-	5mm - 15mm	35,0(1.38")	
LH	-	5mm - 10mm	40,0(1.58")	PULL 10,55 cm <sup>2</sup> (1.64 in <sup>2</sup> )
LH	D	5mm	45,0(1.78")	
LS	S,R	5mm	45,0(1.78")	

	Standard Threads	"EM" Option
"B"	G1/8 PORT	1/8-27
"C"	M8X1,25	5/16-18

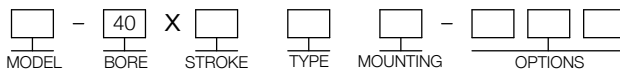
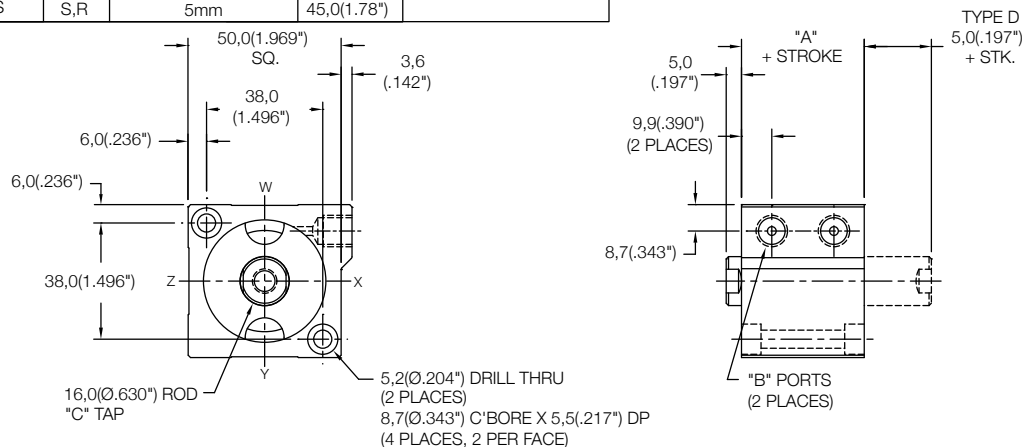

MODEL  
LS  
LE  
LH

5mm - 100mm STROKE  
(SEE STROKE RANGE)

BLANK - NO CODE, DOUBLE ACTING, SINGLE ROD  
D - DOUBLE ACTING, DOUBLE ROD  
S - SINGLE ACTING, SPRING RETRACT  
R - SINGLE ACTING, SPRING EXTEND

MT - THRU MOUNT  
MF - FRONT MOUNT  
MR - REAR MOUNT  
MB - BOTH END MOUNTS  
FF - FRONT FLANGE  
FR - REAR FLANGE  
(FOR FLANGES SEE PAGE 92)

PR - REAR PIVOT  
PL - LONG PIVOT  
(FOR PIVOTS SEE PAGE 94)

- EM - INCH THREADS & PORT OPTIONS
- HS - HIGH TEMPERATURE SEALS OPTION: AVAILABLE ON LE AND LH MODELS ONLY (SEE PAGE 97)
- PE - PORT ENLARGEMENT (AVAILABLE W/ "EM" OPTION ONLY = 1/4-18 NPT PORTS)
- RE - ROD EYE (SEE PAGE 96)
- RS - MALE STUD FOR ROD END (SEE PAGE 96)
- RF, RH, RN, RT, RV, RY - ROD EXTENSIONS (SEE PAGE 96)
- SH - HYDRAULIC OPTION (35 BAR 500 PSI) (SEE PAGE 97)
- UB, UF, UR - URETHANE SHOCK PAD OPTION (SEE PAGE 97)

## Magnetic Front Mount Cylinder "MF"

MODEL	TYPE	STANDARD STROKES	"A"	PISTON AREA
LS	_D	5mm - 100mm	30,0(1.18")	PUSH 12,56 cm <sup>2</sup> (1.95 in <sup>2</sup> ) PULL 10,55 cm <sup>2</sup> (1.64 in <sup>2</sup> )
LE	-	5mm - 100mm	40,0(1.58")	
LH	-	5mm - 100mm	45,0(1.78")	PULL 10,55 cm <sup>2</sup> (1.64 in <sup>2</sup> )
LH	D	5mm - 100mm	50,0(1.98")	
LS	S,R	5mm - 25mm	50,0(1.97")	
LS	S,R	26mm - 50mm	60,0(2.36")	

	Standard Threads	"EM" Option
"B"	G1/8 PORT	1/8-27
"C"	M8X1,25	5/16-18
"D"	M6X1,0	1/4-20

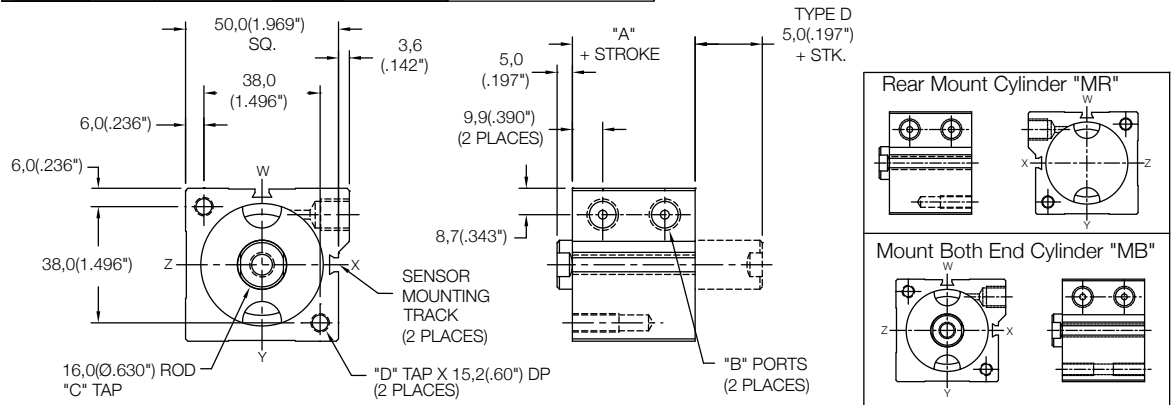

## Magnetic Thru Mount Cylinder "MT"

MODEL	TYPE	STANDARD STROKES	"A"	PISTON AREA
LS	_D	5mm - 20mm	30,0(1.18")	PUSH 12,56 cm <sup>2</sup> (1.95 in <sup>2</sup> ) PULL 10,55 cm <sup>2</sup> (1.64 in <sup>2</sup> )
LE	-	5mm - 10mm	40,0(1.58")	
LH	-	5mm	45,0(1.78")	PULL 10,55 cm <sup>2</sup> (1.64 in <sup>2</sup> )

	Standard Threads	"EM" Option
"B"	G1/8 PORT	1/8-27
"C"	M8X1,25	5/16-18

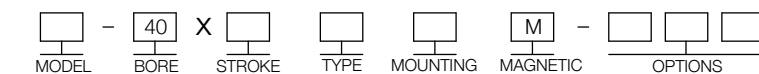
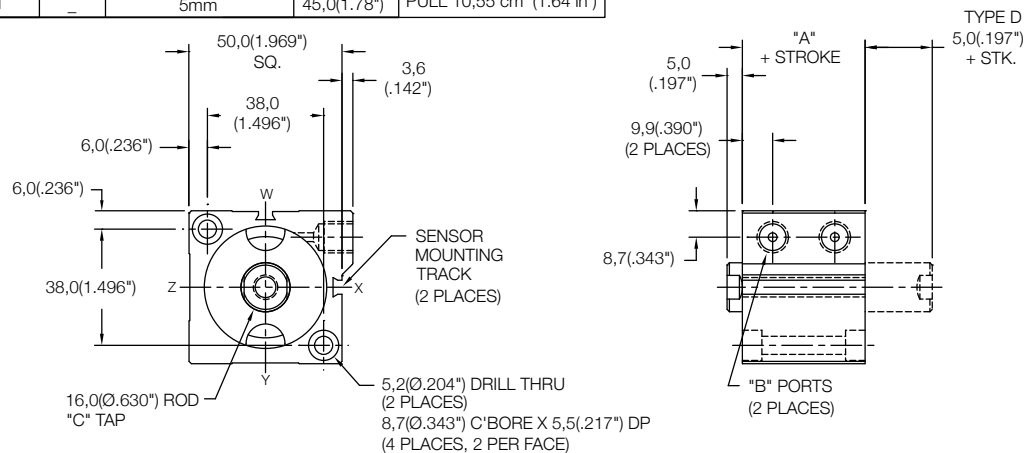

- MODEL**  
 LS  
 LE  
 LH  
 5mm - 100mm STROKE  
 (SEE STROKE RANGE)  
 BLANK - NO CODE, DOUBLE  
 ACTING, SINGLE ROD  
 D - DOUBLE ACTING, DOUBLE ROD  
 S - SINGLE ACTING, SPRING RETRACT  
 R - SINGLE ACTING, SPRING EXTEND  
 MT - THRU MOUNT  
 MF - FRONT MOUNT  
 MR - REAR MOUNT  
 MB - BOTH END MOUNTS  
 FF - FRONT FLANGE  
 FR - REAR FLANGE  
 (FOR FLANGES SEE PAGE 92)  
 PR - REAR PIVOT  
 PL - LONG PIVOT  
 (FOR PIVOTS SEE PAGE 94)

SENSORS SOLD SEPARATELY  
 SKS, SKP, SCS, SCP - SOLID STATE  
 LIMIT SENSORS (SEE PAGE 88)

- EM - INCH THREADS & PORT OPTIONS  
 HS - HIGH TEMPERATURE SEALS OPTION:  
 AVAILABLE ON LE AND LH MODELS ONLY  
 (SEE PAGE 97)  
 PE - PORT ENLARGEMENT (AVAILABLE W/  
 "EM" OPTION ONLY = 1/4-18 NPT PORTS)  
 RE - ROD EYE  
 (SEE PAGE 96)  
 RS - MALE STUD FOR ROD END  
 (SEE PAGE 96)  
 RF, RH, RN, RT, RV, RY - ROD EXTENSIONS  
 (SEE PAGE 96)  
 SH - HYDRAULIC OPTION (35 BAR 500 PSI)  
 (SEE PAGE 97)  
 UB, UF, UR - URETHANE SHOCK PAD OPTION  
 (SEE PAGE 97)

## Magnetic Side Mount Cylinder "MS"

MODEL	TYPE	STANDARD STROKES	"A"	PISTON AREA
LS	_,D	5mm - 15mm	30,0(1.18")	PUSH 12,56 cm <sup>2</sup> (1.95 in <sup>2</sup> )
LE	-	5mm	40,0(1.58")	PULL 10,55 cm <sup>2</sup> (1.64 in <sup>2</sup> )

	Standard Threads	"EM" Option
"B"	G1/8 PORT	1/8-27
"C"	M8X1,25	5/16-18
"D"	M6X1,0	1/4-20

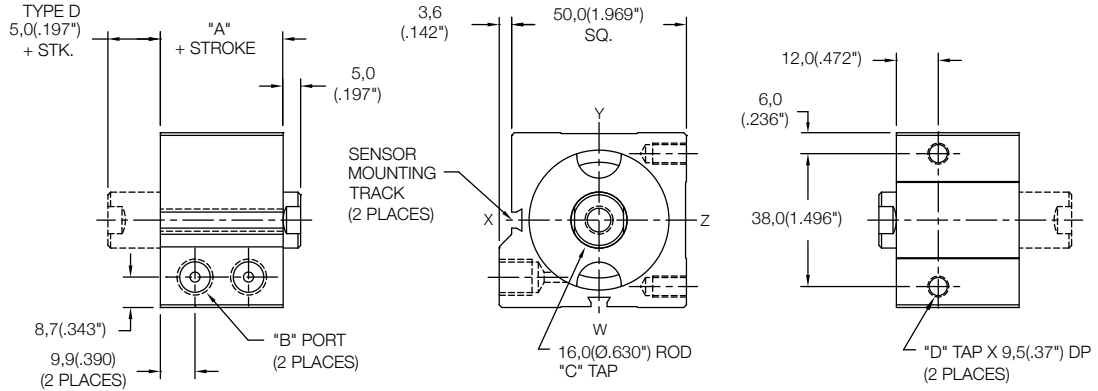

## Magnetic Side Mount Cylinder "MS"

MODEL	TYPE	STANDARD STROKES	"A"	PISTON AREA
LS	_,D	20mm - 100mm	30,0(1.18")	PUSH 12,56 cm <sup>2</sup> (1.95 in <sup>2</sup> )
LE	-	10mm - 100mm	40,0(1.58")	PULL 10,55 cm <sup>2</sup> (1.64 in <sup>2</sup> )
LH	-	5mm - 100mm	45,0(1.78")	
LH	D	5mm - 100mm	50,0(1.97")	
LS	S,R	5mm - 25mm	50,0(1.97")	
LS	S,R	26mm - 50mm	60,0(2.36")	

	Standard Threads	"EM" Option
"B"	G1/8 PORT	1/8-27
"C"	M8X1,25	5/16-18
"D"	M6X1,0	1/4-20

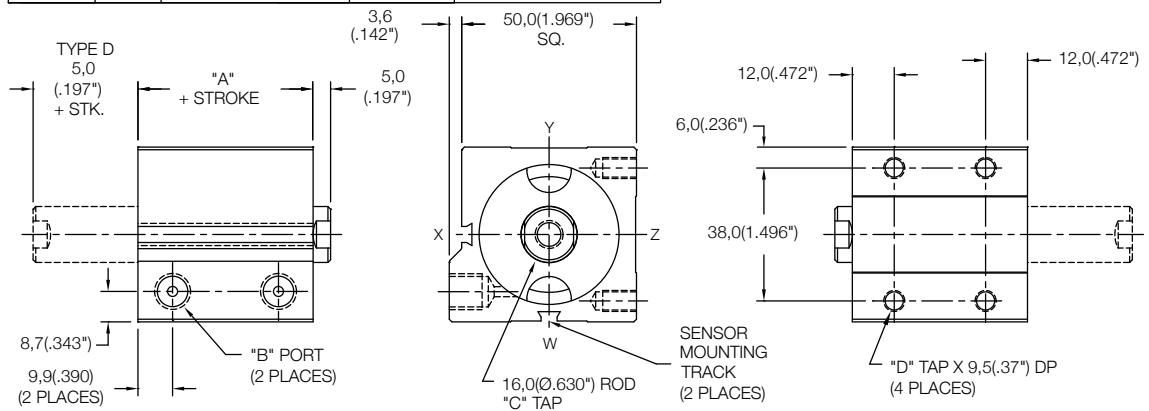

SENSORS SOLD SEPARATELY  
 SKS, SKP, SCS, SCP - SOLID STATE  
 LIMIT SENSORS (SEE PAGE 88)

<div style="border: 1px solid black; width: 20px; height: 20px; margin: 0 auto;"></div> MODEL LS LE LH	-	<div style="border: 1px solid black; width: 20px; height: 20px; margin: 0 auto;"></div> BORE 40	X	<div style="border: 1px solid black; width: 20px; height: 20px; margin: 0 auto;"></div> STROKE 5mm - 100mm STROKE (SEE STROKE RANGE)	<div style="border: 1px solid black; width: 20px; height: 20px; margin: 0 auto;"></div> TYPE BLANK - NO CODE, DOUBLE ACTING, SINGLE ROD D - DOUBLE ACTING, DOUBLE ROD S - SINGLE ACTING, SPRING RETRACT R - SINGLE ACTING, SPRING EXTEND	<div style="border: 1px solid black; width: 20px; height: 20px; margin: 0 auto;"></div> MOUNTING MS - SIDE MOUNT FE - FLANGE ON END FS - FLANGE ON SIDE (SEE PAGE 93)	<div style="border: 1px solid black; width: 20px; height: 20px; margin: 0 auto;"></div> MAGNETIC M	-	<div style="border: 1px solid black; width: 20px; height: 20px; margin: 0 auto;"></div> OPTIONS EM - INCH THREADS & PORT OPTIONS HS - HIGH TEMPERATURE SEALS OPTION: AVAILABLE ON LE AND LH MODELS ONLY (SEE PAGE 97) PE - PORT ENLARGEMENT (AVAILABLE W/ "EM" OPTION ONLY = 1/4-18 NPT PORTS) RE - ROD EYE (SEE PAGE 96) RS - MALE STUD FOR ROD END (SEE PAGE 96) RF, RH, RN, RT, RV, RY - ROD EXTENSIONS (SEE PAGE 96) SH - HYDRAULIC OPTION (35 BAR 500 PSI) (SEE PAGE 97) UB, UF, UR - URETHANE SHOCK PAD OPTION (SEE PAGE 97)
---	---	--	---	--	---	---	---	---	--

## Non Magnetic Side Mount Cylinder "MS"

MODEL	TYPE	STANDARD STROKES	"A"	PISTON AREA
LS	...D	10mm - 20mm	25,0(0.98")	PUSH 12,56 cm <sup>2</sup> (1.95 in <sup>2</sup> )
LE	-	5mm - 10mm	35,0(1.38")	PULL 10,55 cm <sup>2</sup> (1.64 in <sup>2</sup> )
LH	-	5mm	40,0(1.58")	

	Standard Threads	"EM" Option
"B"	G1/8 PORT	1/8-27
"C"	M8X1,25	5/16-18
"D"	M6X1,0	1/4-20

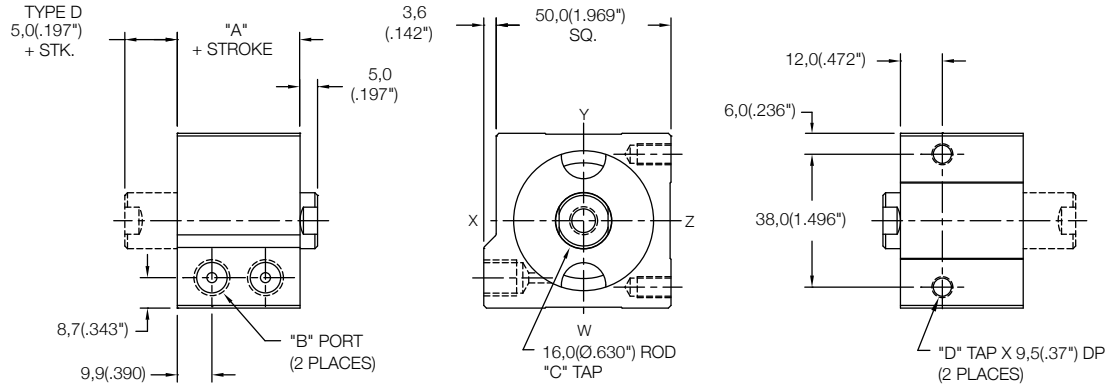

## Non Magnetic Side Mount Cylinder "MS"

MODEL	TYPE	STANDARD STROKES	"A"	PISTON AREA
LS	...D	25mm - 100mm	25,0(0.98")	PUSH 12,56 cm <sup>2</sup> (1.95 in <sup>2</sup> )
LE	-	15mm - 100mm	35,0(1.38")	PULL 10,55 cm <sup>2</sup> (1.64 in <sup>2</sup> )
LH	-	10mm - 100mm	40,0(1.58")	
LH	D	5mm - 100mm	45,0(1.78")	
LS	S,R	5mm - 25mm	45,0(1.78")	
LS	S,R	26mm - 50mm	55,0(2.17")	

	Standard Threads	"EM" Option
"B"	G1/8 PORT	1/8-27
"C"	M8X1,25	5/16-18
"D"	M6X1,0	1/4-20

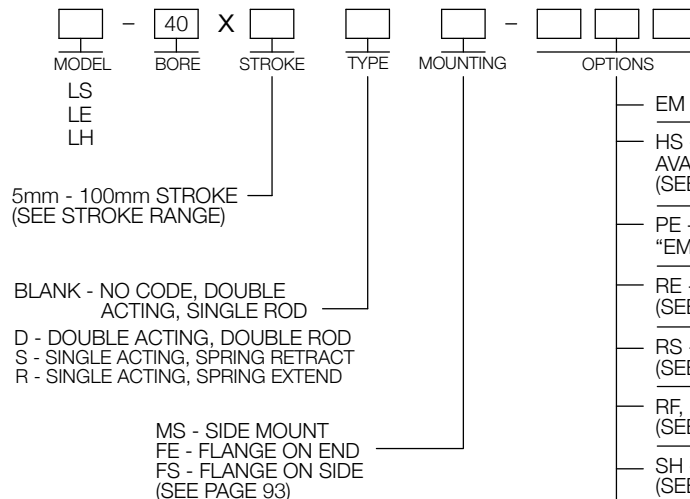
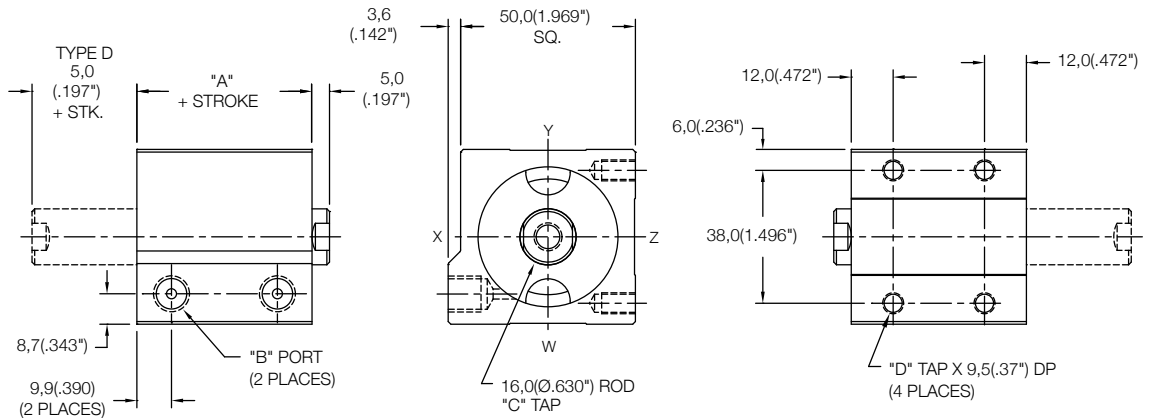

- EM - INCH THREADS & PORT OPTIONS
- HS - HIGH TEMPERATURE SEALS OPTION: AVAILABLE ON LE AND LH MODELS ONLY (SEE PAGE 97)
- PE - PORT ENLARGEMENT (AVAILABLE W/ "EM" OPTION ONLY = 1/4-18 NPT PORTS)
- RE - ROD EYE (SEE PAGE 96)
- RS - MALE STUD FOR ROD END (SEE PAGE 96)
- RF, RH, RN, RT, RV, RY - ROD EXTENSIONS (SEE PAGE 96)
- SH - HYDRAULIC OPTION (35 BAR 500 PSI) (SEE PAGE 97)
- UB, UF, UR - URETHANE SHOCK PAD OPTION (SEE PAGE 97)

### Non Magnetic Front Mount Cylinder "MF"

MODEL	TYPE	STANDARD STROKES	"A"	PISTON AREA
LS	_,D	10mm - 100mm	28,5(1.12")	PUSH 19,63 cm <sup>2</sup> (3.04 in <sup>2</sup> )
LE	_	5mm - 100mm	38,5(1.52")	
LH	_	5mm - 100mm	43,5(1.72")	PULL 17,62 cm <sup>2</sup> (2.73 in <sup>2</sup> )
LH	D	5mm - 100mm	48,5(1.91")	
LS	S,R	5mm - 25mm	48,5(1.91")	
LS	S,R	26mm - 50mm	58,5(2.31")	

	Standard Threads	"EM" Option
"B"	G1/8 PORT	1/8-27
"C"	M10X1,5	3/8-24
"D"	M8X1,25	5/16-18

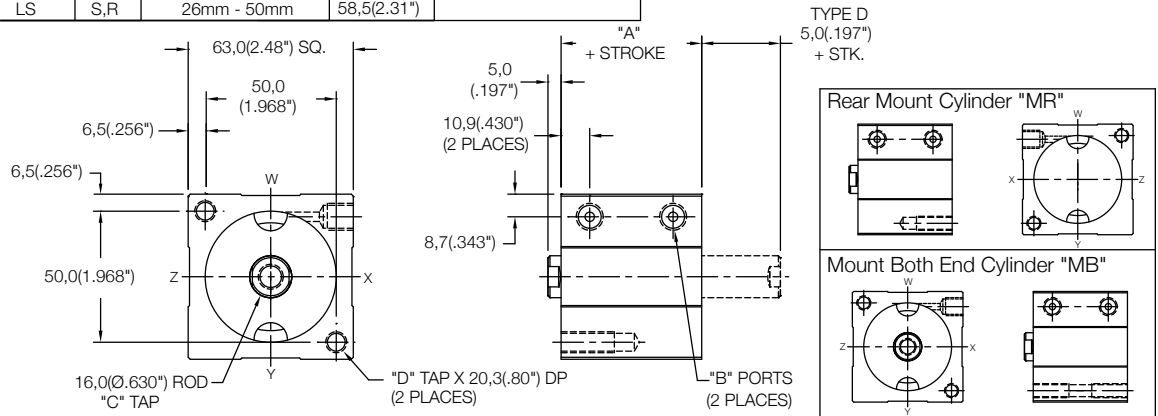

### Non Magnetic Thru Mount Cylinder "MT"

MODEL	TYPE	STANDARD STROKES	"A"	PISTON AREA
LS	_,D	10mm - 40mm	28,5(1.12")	PUSH 19,63 cm <sup>2</sup> (3.04 in <sup>2</sup> )
LE	_	5mm - 30mm	38,5(1.52")	
LH	_	5mm - 25mm	43,5(1.72")	PULL 17,62 cm <sup>2</sup> (2.73 in <sup>2</sup> )
LH	D	5mm - 20mm	48,5(1.91")	
LS	S,R	5mm - 20mm	48,5(1.91")	

	Standard Threads	"EM" Option
"B"	G1/8 PORT	1/8-27
"C"	M10X1,5	3/8-24

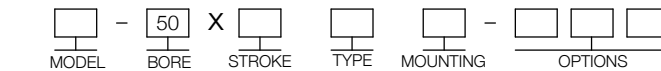
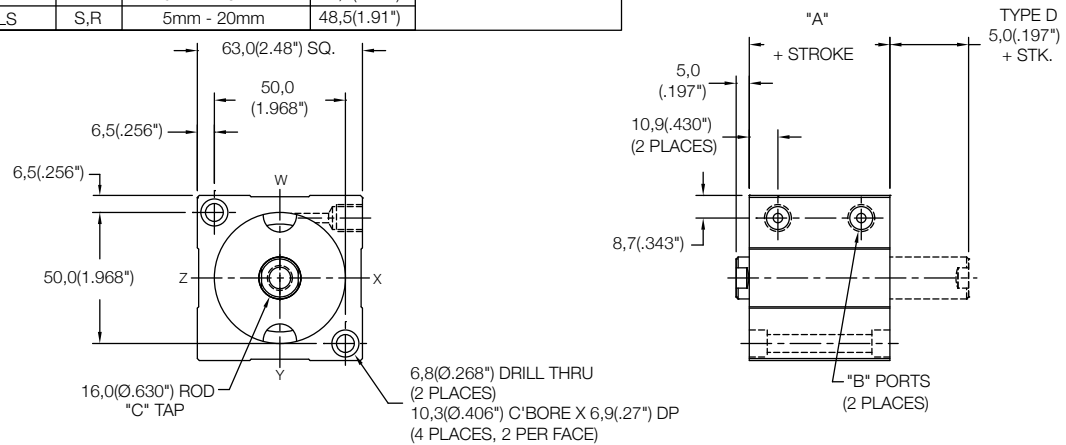

MODEL  
LS  
LE  
LH

5mm - 100mm STROKE  
(SEE STROKE RANGE)

BLANK - NO CODE, DOUBLE  
ACTING, SINGLE ROD

D - DOUBLE ACTING, DOUBLE ROD  
S - SINGLE ACTING, SPRING RETRACT  
R - SINGLE ACTING, SPRING EXTEND

MT - THRU MOUNT  
MF - FRONT MOUNT  
MR - REAR MOUNT  
MB - BOTH END MOUNTS  
FF - FRONT FLANGE  
FR - REAR FLANGE  
(FOR FLANGES SEE PAGE 92)

PR - REAR PIVOT  
PL - LONG PIVOT  
(FOR PIVOTS SEE PAGE 94)

EM - INCH THREADS & PORT OPTIONS

HS - HIGH TEMPERATURE SEALS OPTION:  
AVAILABLE ON LE AND LH MODELS ONLY  
(SEE PAGE 97)

PE - PORT ENLARGEMENT (AVAILABLE W/  
"EM" OPTION ONLY = 1/4-18 NPT PORTS)

RE - ROD EYE  
(SEE PAGE 96)

RS - MALE STUD FOR ROD END  
(SEE PAGE 96)

RF, RH, RN, RT, RV, RY - ROD EXTENSIONS  
(SEE PAGE 96)

SH - HYDRAULIC OPTION (35 BAR 500 PSI)  
(SEE PAGE 97)

UB, UF, UR - URETHANE SHOCK PAD OPTION  
(SEE PAGE 97)



### Magnetic Front Mount Cylinder "MF"

MODEL	TYPE	STANDARD STROKES	"A"	PISTON AREA
LS	..D	5mm - 100mm	33,5(1.32")	PUSH 19,63 cm <sup>2</sup> (3.04 in <sup>2</sup> )
LE	-	5mm - 100mm	43,5(1.72")	
LH	-	5mm - 100mm	48,5(1.91")	PULL 17,62 cm <sup>2</sup> (2.73 in <sup>2</sup> )
LH	D	5mm - 100mm	53,5(2.11")	
LS	S,R	5mm - 25mm	53,5(2.11")	
LS	S,R	26mm - 50mm	63,5(2.50")	

	Standard Threads	"EM" Option
"B"	G1/8 PORT	1/8-27
"C"	M10X1,5	3/8-24
"D"	M8X1,25	5/16-18

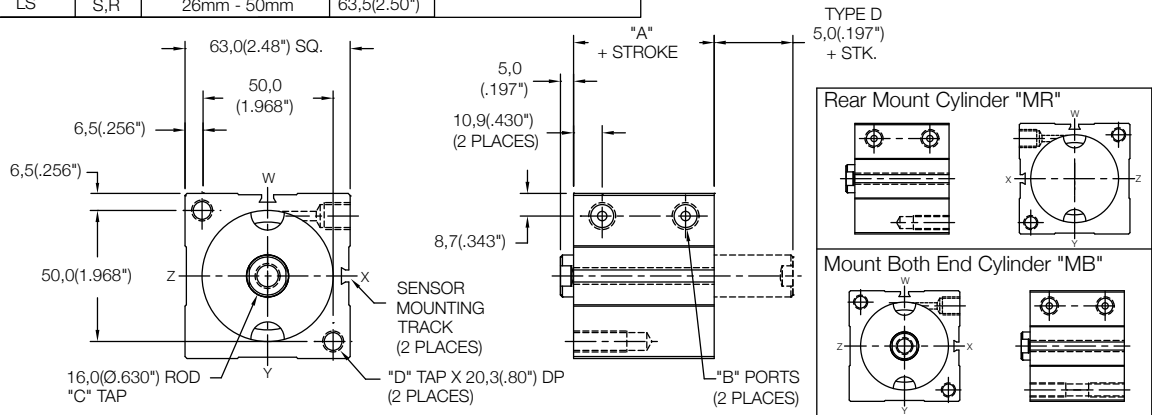

### Magnetic Thru Mount Cylinder "MT"

MODEL	TYPE	STANDARD STROKES	"A"	PISTON AREA
LS	..D	5mm - 35mm	33,5(1.32")	PUSH 19,63 cm <sup>2</sup> (3.04 in <sup>2</sup> )
LE	-	5mm - 25mm	43,5(1.72")	
LH	-	5mm - 20mm	48,5(1.91")	PULL 17,62 cm <sup>2</sup> (2.73 in <sup>2</sup> )
LH	D	5mm - 15mm	53,5(2.11")	
LS	S,R	5mm - 15mm	53,5(2.11")	

	Standard Threads	"EM" Option
"B"	G1/8 PORT	1/8-27
"C"	M10X1,5	3/8-24

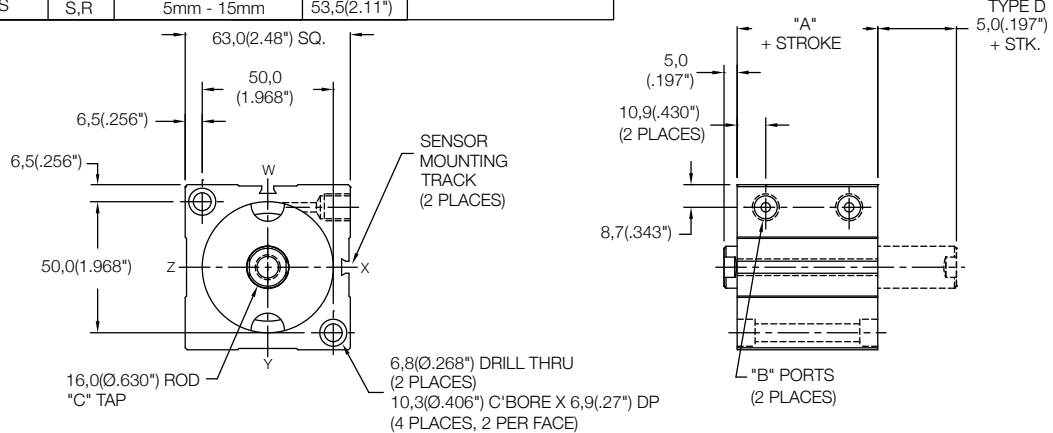

<p>MODEL: LS, LE, LH</p> <p>BORE: 50</p> <p>STROKE: 5mm - 100mm (SEE STROKE RANGE)</p> <p>TYPE: BLANK - NO CODE, DOUBLE ACTING, SINGLE ROD; D - DOUBLE ACTING, DOUBLE ROD; S - SINGLE ACTING, SPRING RETRACT; R - SINGLE ACTING, SPRING EXTEND</p> <p>MOUNTING: MT - THRU MOUNT; MF - FRONT MOUNT; MR - REAR MOUNT; MB - BOTH END MOUNTS; FF - FRONT FLANGE; FR - REAR FLANGE (FOR FLANGES SEE PAGE 92); PR - REAR PIVOT; PL - LONG PIVOT (FOR PIVOTS SEE PAGE 94)</p>	<p>MAGNETIC: M</p> <p>OPTIONS: EM - INCH THREADS &amp; PORT OPTIONS; HS - HIGH TEMPERATURE SEALS OPTION: AVAILABLE ON LE AND LH MODELS ONLY (SEE PAGE 97); PE - PORT ENLARGEMENT (AVAILABLE W/ "EM" OPTION ONLY = 1/4-18 NPT PORTS); RE - ROD EYE (SEE PAGE 96); RS - MALE STUD FOR ROD END (SEE PAGE 96); RF, RH, RN, RT, RV, RY - ROD EXTENSIONS (SEE PAGE 96); SH - HYDRAULIC OPTION (35 BAR 500 PSI) (SEE PAGE 97); UB, UF, UR - URETHANE SHOCK PAD OPTION (SEE PAGE 97)</p>	<p>SENSORS SOLD SEPARATELY: SKS, SKP, SCS, SCP - SOLID STATE LIMIT SENSORS (SEE PAGE 54)</p>
--	--	--

## Magnetic Side Mount Cylinder "MS"

MODEL	TYPE	STANDARD STROKES	"A"	PISTON AREA
LS	_,D	5mm - 15mm	33,5(1.32")	PUSH 19,63 cm <sup>2</sup> (3.04 in <sup>2</sup> )
LE	_	5mm	43,5(1.72")	PULL 17,62 cm <sup>2</sup> (2.73 in <sup>2</sup> )

	Standard Threads	"EM" Option
"B"	G1/8 PORT	1/8-27
"C"	M10X1,5	3/8-24
"D"	M8X1,25	5/16-18

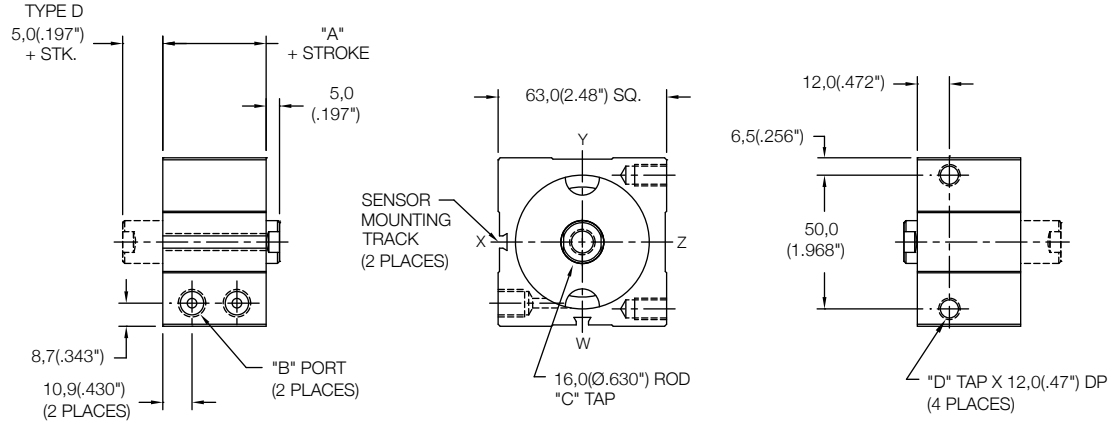

## Magnetic Side Mount Cylinder "MS"

MODEL	TYPE	STANDARD STROKES	"A"	PISTON AREA
LS	_,D	20mm - 100mm	33,5(1.32")	PUSH 19,63 cm <sup>2</sup> (3.04 in <sup>2</sup> )
LE	_	10mm - 100mm	43,5(1.72")	
LH	_	5mm - 100mm	48,5(1.91")	PULL 17,62 cm <sup>2</sup> (2.73 in <sup>2</sup> )
LH	D	5mm - 100mm	53,5(2.11")	
LS	S,R	5mm - 25mm	53,5(2.11")	
LS	S,R	26mm - 50mm	63,5(2.50")	

	Standard Threads	"EM" Option
"B"	G1/8 PORT	1/8-27
"C"	M10X1,5	3/8-24
"D"	M8X1,25	5/16-18

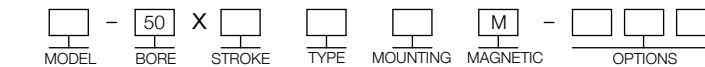
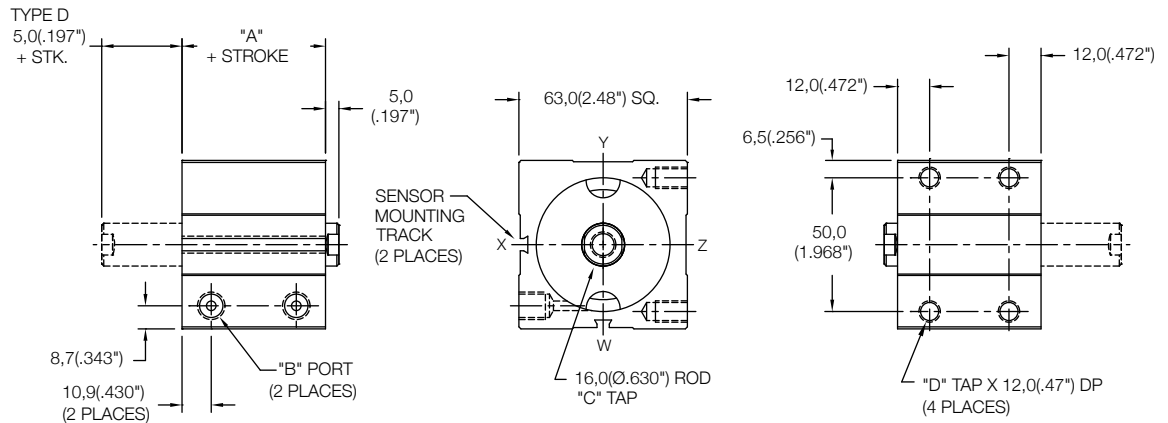

SENSORS SOLD SEPARATELY  
SKS, SKP, SCS, SCP - SOLID STATE  
LIMIT SENSORS (SEE PAGE 88)

LS  
LE  
LH

5mm - 100mm STROKE  
(SEE STROKE RANGE)

BLANK - NO CODE, DOUBLE  
ACTING, SINGLE ROD

D - DOUBLE ACTING, DOUBLE ROD  
S - SINGLE ACTING, SPRING RETRACT  
R - SINGLE ACTING, SPRING EXTEND

MS - SIDE MOUNT  
FE - FLANGE ON END  
FS - FLANGE ON SIDE  
(SEE PAGE 93)

EM - INCH THREADS & PORT OPTIONS

HS - HIGH TEMPERATURE SEALS OPTION:  
AVAILABLE ON LE AND LH MODELS ONLY  
(SEE PAGE 97)

PE - PORT ENLARGEMENT (AVAILABLE W/  
"EM" OPTION ONLY = 1/4-18 NPT PORTS)

RE - ROD EYE  
(SEE PAGE 96)

RS - MALE STUD FOR ROD END  
(SEE PAGE 96)

RF, RH, RN, RT, RV, RY - ROD EXTENSIONS  
(SEE PAGE 96)

SH - HYDRAULIC OPTION (35 BAR 500 PSI)  
(SEE PAGE 97)

UB, UF, UR - URETHANE SHOCK PAD OPTION  
(SEE PAGE 97)

## Non Magnetic Side Mount Cylinder "MS"

MODEL	TYPE	STANDARD STROKES	"A"	PISTON AREA
LS	_D	10mm - 20mm	28,5(1.12")	PUSH 19,63 cm <sup>2</sup> (3.04 in <sup>2</sup> )
LE	-	5mm - 10mm	38,5(1.52")	PULL 17,62 cm <sup>2</sup> (2.73 in <sup>2</sup> )
LH	-	5mm	43,5(1.72")	

	Standard Threads	"EM" Option
"B"	G1/8 PORT	1/8-27
"C"	M10X1,5	3/8-24
"D"	M8X1,25	5/16-18

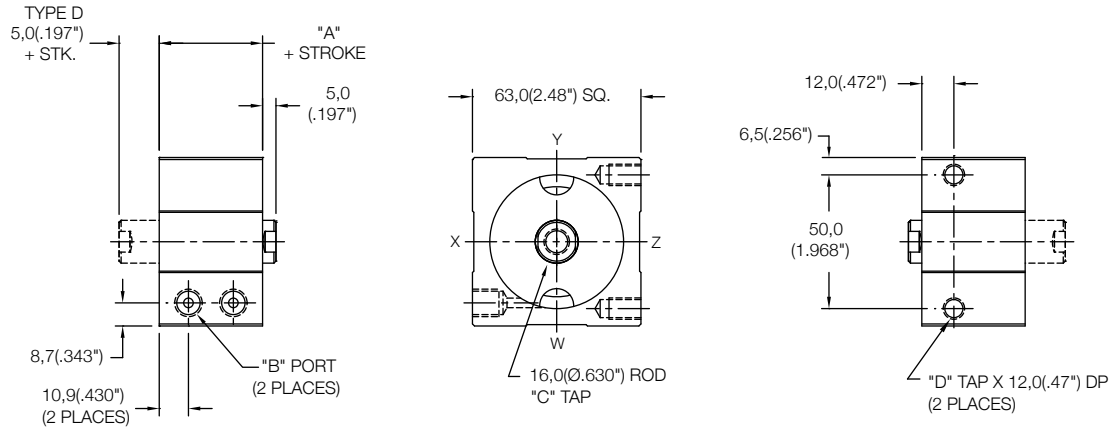

## Non Magnetic Side Mount Cylinder "MS"

MODEL	TYPE	STANDARD STROKES	"A"	PISTON AREA
LS	_D	25mm - 100mm	28,5(1.12")	PUSH 19,63 cm <sup>2</sup> (3.04 in <sup>2</sup> )
LE	-	15mm - 100mm	38,5(1.52")	PULL 17,62 cm <sup>2</sup> (2.73 in <sup>2</sup> )
LH	-	10mm - 100mm	43,5(1.72")	
LH	D	5mm - 100mm	48,5(1.91")	
LS	S,R	5mm - 25mm	48,5(1.91")	
LS	S,R	26mm - 50mm	58,5(2.31")	

	Standard Threads	"EM" Option
"B"	G1/8 PORT	1/8-27
"C"	M10X1,5	3/8-24
"D"	M8X1,25	5/16-18

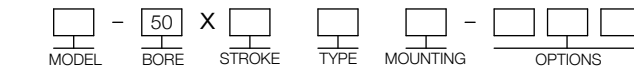
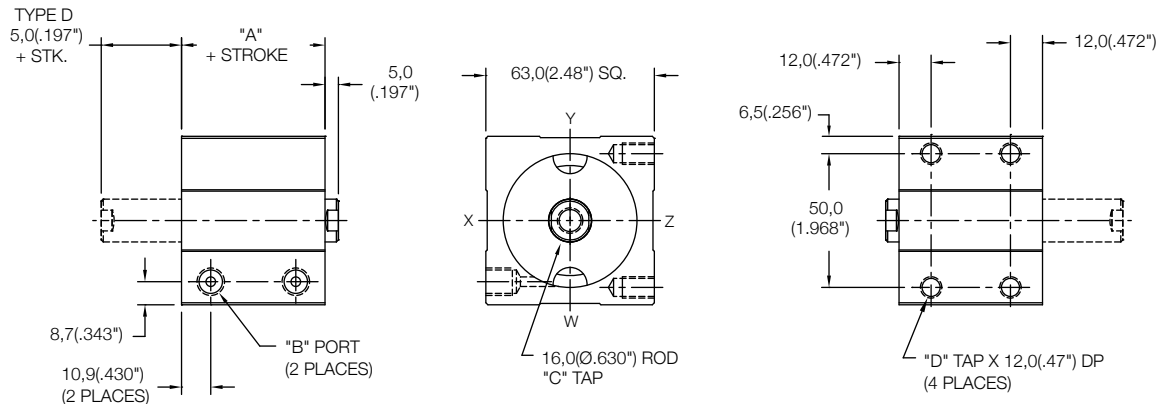

LS  
LE  
LH

5mm - 100mm STROKE  
(SEE STROKE RANGE)

BLANK - NO CODE, DOUBLE ACTING, SINGLE ROD

D - DOUBLE ACTING, DOUBLE ROD

S - SINGLE ACTING, SPRING RETRACT

R - SINGLE ACTING, SPRING EXTEND

MS - SIDE MOUNT

FE - FLANGE ON END

FS - FLANGE ON SIDE  
(SEE PAGE 93)

EM - INCH THREADS & PORT OPTIONS

HS - HIGH TEMPERATURE SEALS OPTION:  
AVAILABLE ON LE AND LH MODELS ONLY  
(SEE PAGE 97)

PE - PORT ENLARGEMENT (AVAILABLE W/  
"EM" OPTION ONLY = 1/4-18 NPT PORTS)

RE - ROD EYE  
(SEE PAGE 96)

RS - MALE STUD FOR ROD END  
(SEE PAGE 96)

RF, RH, RN, RT, RV, RY - ROD EXTENSIONS  
(SEE PAGE 96)

SH - HYDRAULIC OPTION (35 BAR 500 PSI)  
(SEE PAGE 97)

UB, UF, UR - URETHANE SHOCK PAD OPTION  
(SEE PAGE 97)

## Non Magnetic Front Mount Cylinder "MF"

MODEL	TYPE	STANDARD STROKES	"A"	PISTON AREA
LS	...D	10mm - 100mm	32,0(1.26")	PUSH 31,17 cm <sup>2</sup> (4.83 in <sup>2</sup> )
LE	-	5mm - 100mm	42,0(1.66")	
LH	...D	5mm - 100mm	52,0(2.05")	PULL 28,03 cm <sup>2</sup> (4.34 in <sup>2</sup> )

	Standard Threads	"EM" Option
"B"	G1/8 PORT	1/8-27
"C"	M12X1,75	1/2-13
"D"	M10X1,5	3/8-24

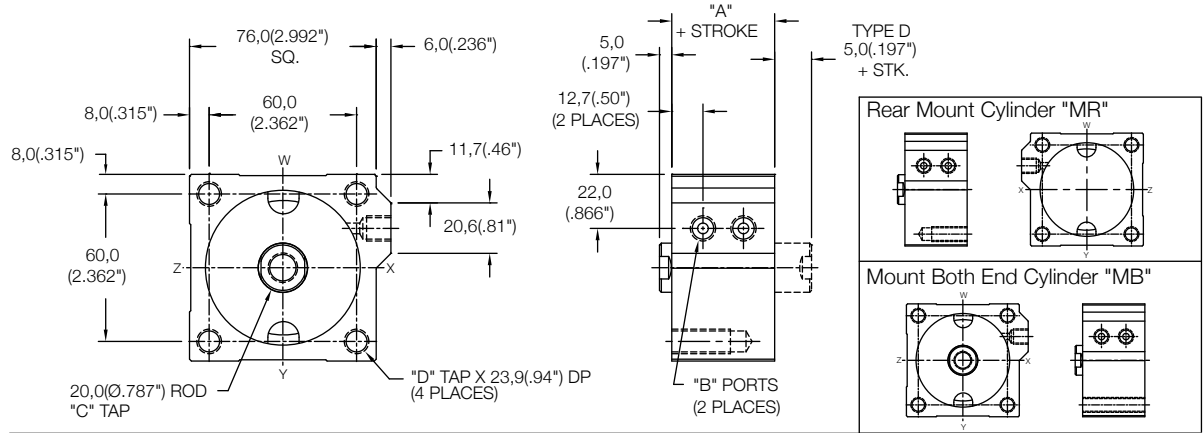

## Non Magnetic Thru Mount Cylinder "MT"

MODEL	TYPE	STANDARD STROKES	"A"	PISTON AREA
LS	...D	10mm - 40mm	32,0(1.26")	PUSH 31,17 cm <sup>2</sup> (4.83 in <sup>2</sup> )
LE	-	5mm - 30mm	42,0(1.66")	
LH	...D	5mm - 20mm	52,0(2.05")	PULL 28,03 cm <sup>2</sup> (4.34 in <sup>2</sup> )

	Standard Threads	"EM" Option
"B"	G1/8 PORT	1/8-27
"C"	M12X1,75	1/2-13

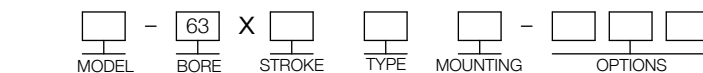
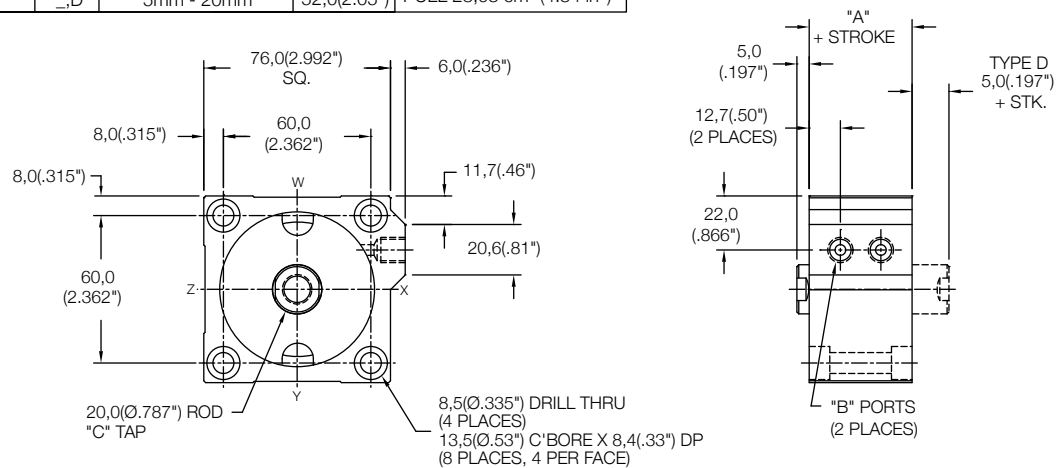

MODEL  
LS  
LE  
LH

5mm - 100mm STROKE  
(SEE STROKE RANGE)

BLANK - NO CODE, DOUBLE ACTING, SINGLE ROD  
D - DOUBLE ACTING, DOUBLE ROD

MT - THRU MOUNT  
MF - FRONT MOUNT  
MR - REAR MOUNT  
MB - BOTH END MOUNTS  
FF - FRONT FLANGE  
FR - REAR FLANGE  
(FOR FLANGES SEE PAGE 92)

PR - REAR PIVOT  
PL - LONG PIVOT  
(FOR PIVOTS SEE PAGE 94)

EM - INCH THREADS & PORT OPTIONS

HS - HIGH TEMPERATURE SEALS OPTION:  
AVAILABLE ON LE AND LH MODELS ONLY  
(SEE PAGE 97)

PE - PORT ENLARGEMENT (AVAILABLE W/  
"EM" OPTION ONLY = 1/4-18 NPT PORTS)

RE - ROD EYE  
(SEE PAGE 96)

RS - MALE STUD FOR ROD END  
(SEE PAGE 96)

RF, RH, RN, RT, RV, RY - ROD EXTENSIONS  
(SEE PAGE 96)

SH - HYDRAULIC OPTION (35 BAR 500 PSI)  
(SEE PAGE 97)

UB, UF, UR - URETHANE SHOCK PAD OPTION  
(SEE PAGE 97)

## Magnetic Front Mount Cylinder "MF"

MODEL	TYPE	STANDARD STROKES	"A"	PISTON AREA
LS	...D	10mm - 100mm	37,0(1.46")	PUSH 31,17 cm <sup>2</sup> (4.83 in <sup>2</sup> )
LE	-	5mm - 100mm	47,0(1.85")	
LH	...D	5mm - 100mm	57,0(2.25")	PULL 28,03 cm <sup>2</sup> (4.34 in <sup>2</sup> )

	Standard Threads	"EM" Option
"B"	G1/8 PORT	1/8-27
"C"	M12X1,75	1/2-13
"D"	M10X1,5	3/8-24

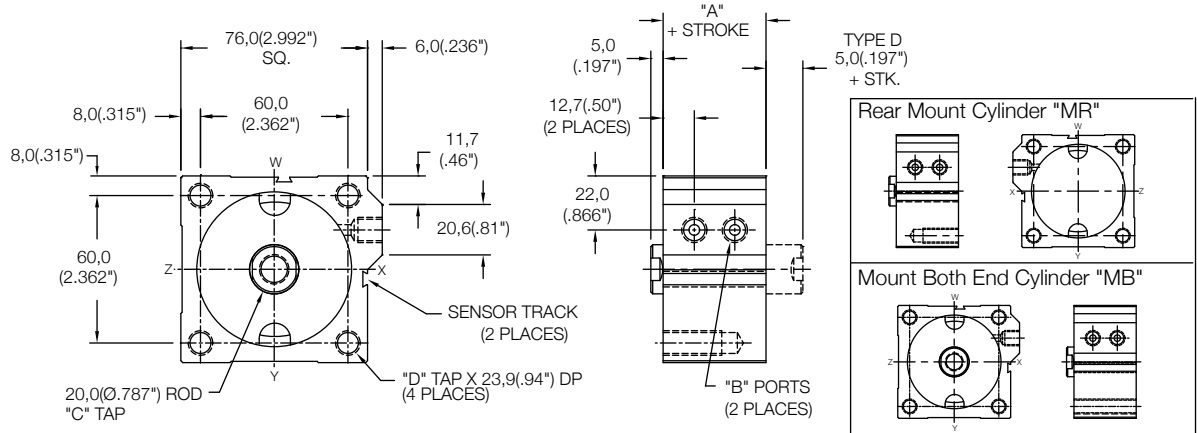

## Magnetic Thru Mount Cylinder "MT"

MODEL	TYPE	STANDARD STROKES	"A"	PISTON AREA
LS	...D	10mm - 35mm	37,0(1.46")	PUSH 31,17 cm <sup>2</sup> (4.83 in <sup>2</sup> )
LE	-	5mm - 25mm	47,0(1.85")	
LH	...D	5mm - 15mm	57,0(2.25")	PULL 28,03 cm <sup>2</sup> (4.34 in <sup>2</sup> )

	Standard Threads	"EM" Option
"B"	G1/8 PORT	1/8-27
"C"	M12X1,75	1/2-13

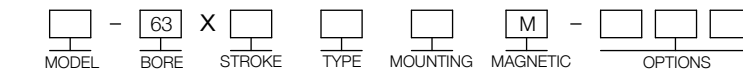
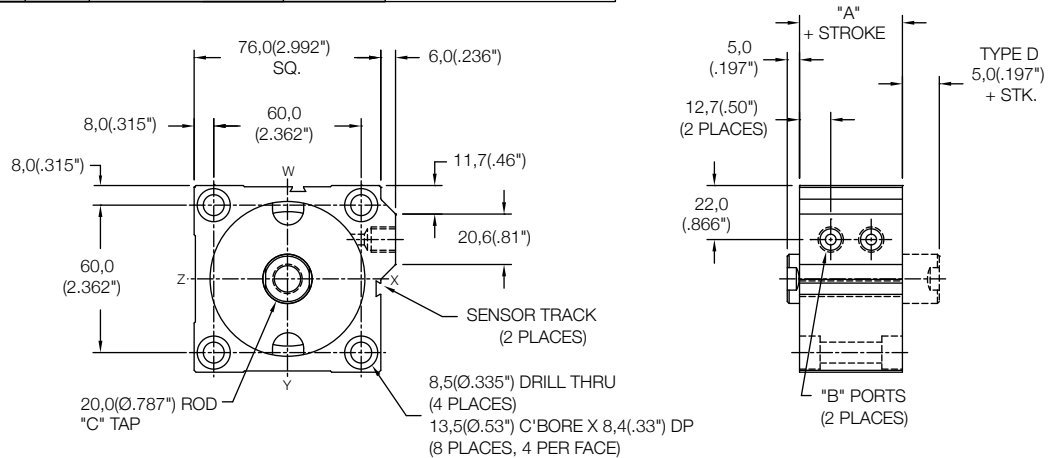

SENSORS SOLD SEPARATELY  
SKS, SKP, SCS, SCP - SOLID STATE  
LIMIT SENSORS (SEE PAGE 88)

- MODEL: LS, LE, LH
- BORE: 63
- STROKE: 5mm - 100mm (SEE STROKE RANGE)
- TYPE: BLANK - NO CODE, DOUBLE ACTING, SINGLE ROD; D - DOUBLE ACTING, DOUBLE ROD
- MOUNTING: MT - THRU MOUNT; MF - FRONT MOUNT; MR - REAR MOUNT; MB - BOTH END MOUNTS; FF - FRONT FLANGE; FR - REAR FLANGE (FOR FLANGES SEE PAGE 92); PR - REAR PIVOT; PL - LONG PIVOT (FOR PIVOTS SEE PAGE 94)
- MAGNETIC: M
- OPTIONS:
  - EM - INCH THREADS & PORT OPTIONS
  - HS - HIGH TEMPERATURE SEALS OPTION: AVAILABLE ON LE AND LH MODELS ONLY (SEE PAGE 97)
  - PE - PORT ENLARGEMENT (AVAILABLE W/ "EM" OPTION ONLY = 1/4-18 NPT PORTS)
  - RE - ROD EYE (SEE PAGE 96)
  - RS - MALE STUD FOR ROD END (SEE PAGE 96)
  - RF, RH, RN, RT, RV, RY - ROD EXTENSIONS (SEE PAGE 96)
  - SH - HYDRAULIC OPTION (35 BAR 500 PSI) (SEE PAGE 97)
  - UB, UF, UR - URETHANE SHOCK PAD OPTION (SEE PAGE 97)

## Magnetic Side Mount Cylinder "MS"

MODEL	TYPE	STANDARD STROKES	"A"	PISTON AREA
LS	..D	10mm - 15mm	37,0(1.46")	PUSH 31,17 cm <sup>2</sup> (4.83 in <sup>2</sup> )
LE	-	5mm	47,0(1.85")	PULL 28,03 cm <sup>2</sup> (4.34 in <sup>2</sup> )

	Standard Threads	"EM" Option
"B"	G1/8 PORT	1/8-27
"C"	M12X1,75	1/2-13
"D"	M8X1,25	5/16-18

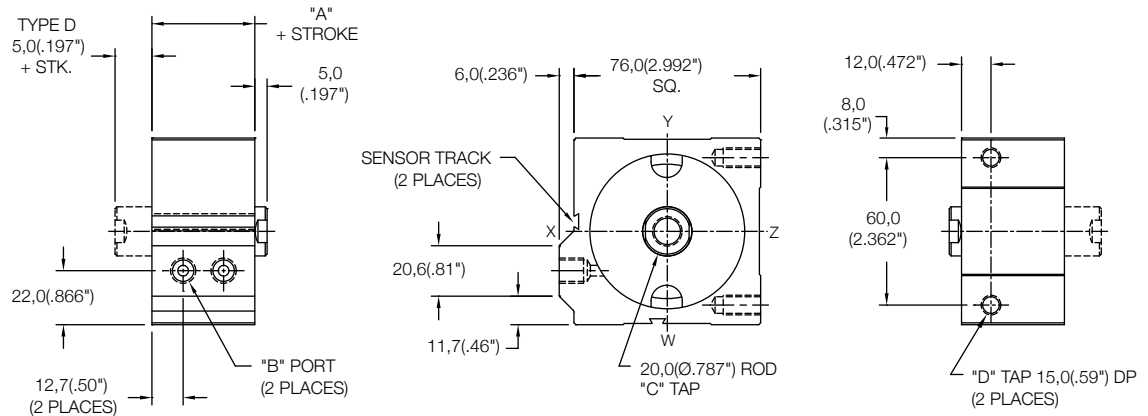

## Magnetic Side Mount Cylinder "MS"

MODEL	TYPE	STANDARD STROKES	"A"	PISTON AREA
LS	..D	20mm - 100mm	37,0(1.46")	PUSH 31,17 cm <sup>2</sup> (4.83 in <sup>2</sup> )
LE	-	10mm - 100mm	47,0(1.85")	PULL 28,03 cm <sup>2</sup> (4.34 in <sup>2</sup> )
LH	..D	5mm - 100mm	57,0(2.25")	PULL 28,03 cm <sup>2</sup> (4.34 in <sup>2</sup> )

	Standard Threads	"EM" Option
"B"	G1/8 PORT	1/8-27
"C"	M12X1,75	1/2-13
"D"	M8X1,25	5/16-18

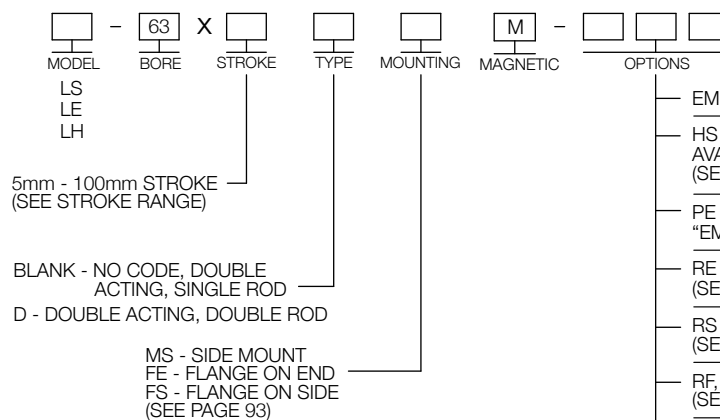
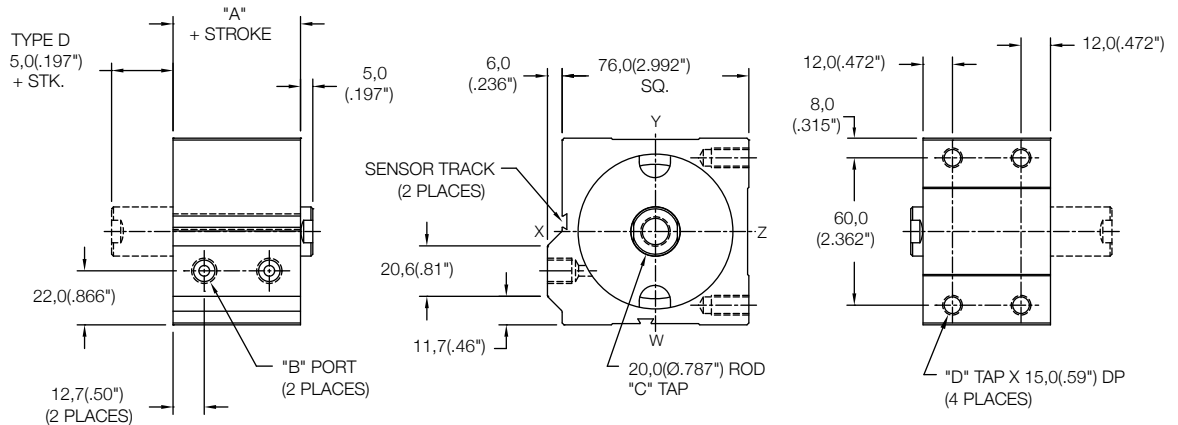

SENSORS SOLD SEPARATELY  
 SKS, SKP, SCS, SCP - SOLID STATE  
 LIMIT SENSORS (SEE PAGE 88)

- EM - INCH THREADS & PORT OPTIONS
- HS - HIGH TEMPERATURE SEALS OPTION:  
AVAILABLE ON LE AND LH MODELS ONLY  
(SEE PAGE 97)
- PE - PORT ENLARGEMENT (AVAILABLE W/  
"EM" OPTION ONLY = 1/4-18 NPT PORTS)
- RE - ROD EYE  
(SEE PAGE 96)
- RS - MALE STUD FOR ROD END  
(SEE PAGE 96)
- RF, RH, RN, RT, RV, RY - ROD EXTENSIONS  
(SEE PAGE 96)
- SH - HYDRAULIC OPTION (35 BAR 500 PSI)  
(SEE PAGE 97)
- UB, UF, UR - URETHANE SHOCK PAD OPTION  
(SEE PAGE 97)

## Non Magnetic Side Mount Cylinder "MS"

MODEL	TYPE	STANDARD STROKES	"A"	PISTON AREA
LS	_,D	10mm - 20mm	32,0(1.26")	PUSH 31,17 cm <sup>2</sup> (4.83 in <sup>2</sup> )
LE	-	5mm - 10mm	42,0(1.66")	PULL 28,03 cm <sup>2</sup> (4.34 in <sup>2</sup> )

	Standard Threads	"EM" Option
"B"	G1/8 PORT	1/8-27
"C"	M12X1,75	1/2-13
"D"	M8X1,25	5/16-18

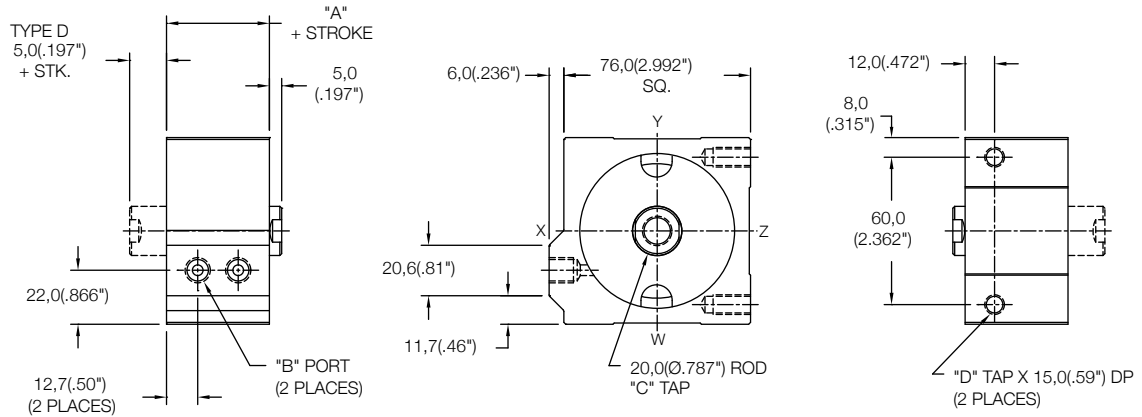

## Non Magnetic Side Mount Cylinder "MS"

MODEL	TYPE	STANDARD STROKES	"A"	PISTON AREA
LS	_,D	25mm - 100mm	32,0(1.26")	PUSH 31,17 cm <sup>2</sup> (4.83 in <sup>2</sup> )
LE	-	15mm - 100mm	42,0(1.66")	PULL 28,03 cm <sup>2</sup> (4.34 in <sup>2</sup> )
LH	_,D	5mm - 100mm	52,0(2.05")	PULL 28,03 cm <sup>2</sup> (4.34 in <sup>2</sup> )

	Standard Threads	"EM" Option
"B"	G1/8 PORT	1/8-27
"C"	M12X1,75	1/2-13
"D"	M8X1,25	5/16-18

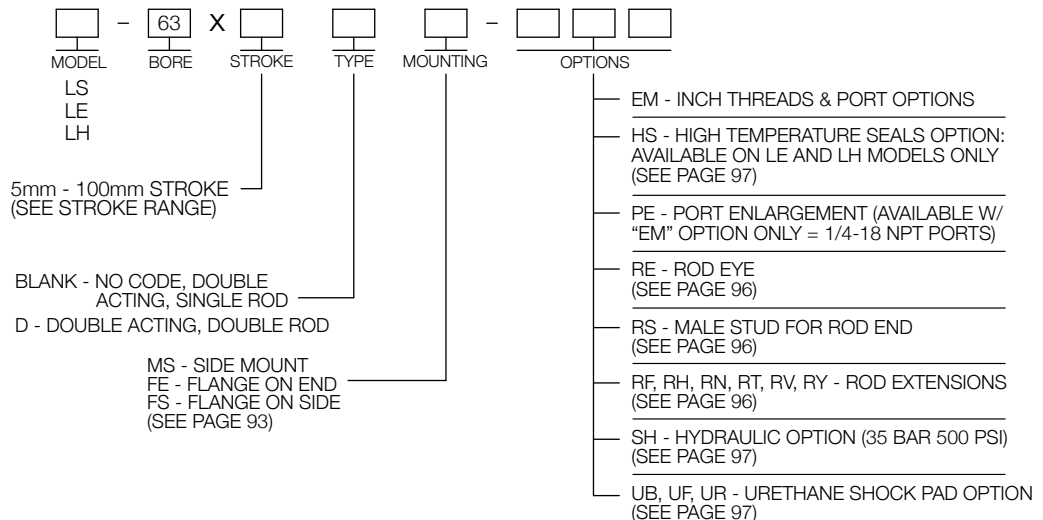
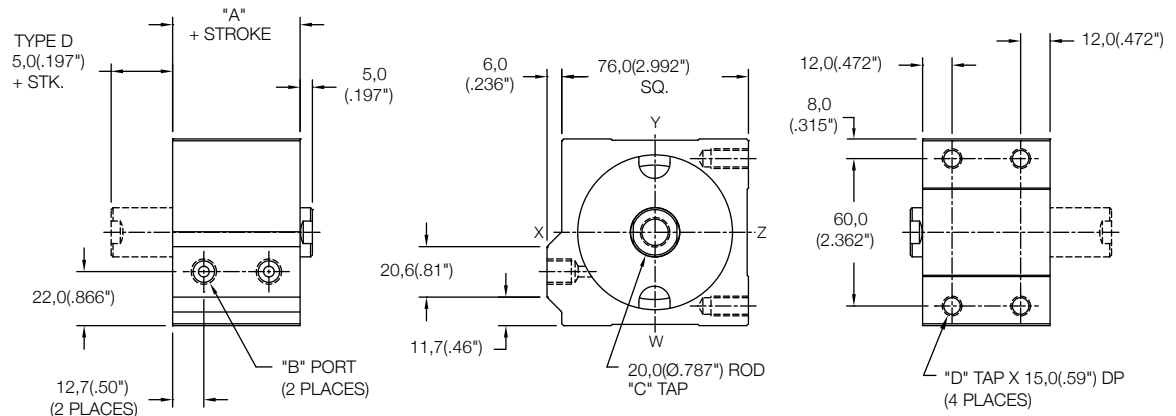

### Non Magnetic Front Mount Cylinder "MF"

MODEL	TYPE	STANDARD STROKES	"A"	PISTON AREA
LS	...D	10mm - 100mm	38,0(1.50")	PUSH 45,6 cm <sup>2</sup> (7.07 in <sup>2</sup> )
LE	-	5mm - 100mm	48,0(1.89")	PULL 42,46 cm <sup>2</sup> (6.59 in <sup>2</sup> )
LH	...D	5mm - 100mm	58,0(2.28")	PULL 42,46 cm <sup>2</sup> (6.59 in <sup>2</sup> )

	Standard Threads	"EM" Option
"B"	G1/8 PORT	1/8-27
"C"	M12X1,75	1/2-13
"D"	M10X1,5	3/8-24

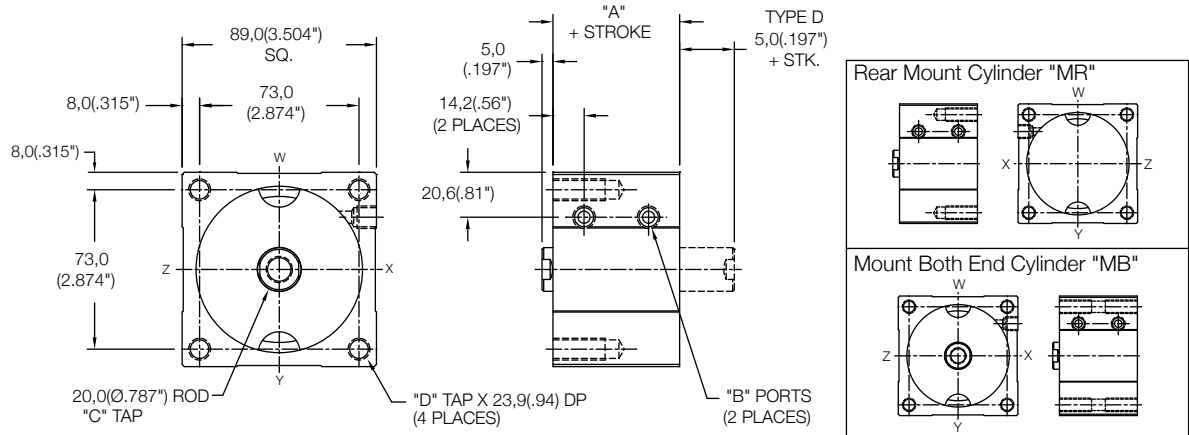

### Non Magnetic Thru Mount Cylinder "MT"

MODEL	TYPE	STANDARD STROKES	"A"	PISTON AREA
LS	...D	10mm - 40mm	38,0(1.50")	PUSH 45,6 cm <sup>2</sup> (7.07 in <sup>2</sup> )
LE	-	5mm - 30mm	48,0(1.89")	PULL 42,46 cm <sup>2</sup> (6.59 in <sup>2</sup> )
LH	...D	5mm - 20mm	58,0(2.28")	PULL 42,46 cm <sup>2</sup> (6.59 in <sup>2</sup> )

	Standard Threads	"EM" Option
"B"	G1/8 PORT	1/8-27
"C"	M12X1,75	1/2-13

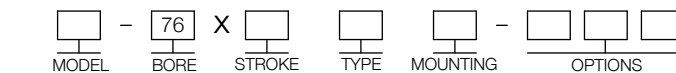
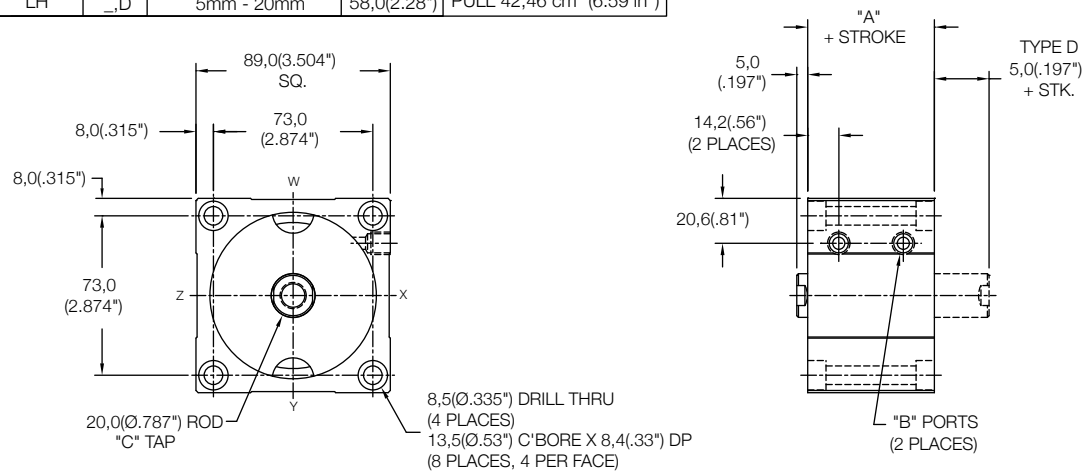

MODEL  
LS  
LE  
LH

5mm - 100mm STROKE  
(SEE STROKE RANGE)

BLANK - NO CODE, DOUBLE ACTING, SINGLE ROD  
D - DOUBLE ACTING, DOUBLE ROD

MT - THRU MOUNT  
MF - FRONT MOUNT  
MR - REAR MOUNT  
MB - BOTH END MOUNTS  
FF - FRONT FLANGE  
FR - REAR FLANGE  
(FOR FLANGES SEE PAGE 92)

PR - REAR PIVOT  
PL - LONG PIVOT  
(FOR PIVOTS SEE PAGE 94)

EM - INCH THREADS & PORT OPTIONS

HS - HIGH TEMPERATURE SEALS OPTION:  
AVAILABLE ON LE AND LH MODELS ONLY  
(SEE PAGE 97)

PE - PORT ENLARGEMENT (AVAILABLE W/  
"EM" OPTION ONLY = 1/4-18 NPT PORTS)

RE - ROD EYE  
(SEE PAGE 96)

RS - MALE STUD FOR ROD END  
(SEE PAGE 96)

RF, RH, RN, RT, RV, RY - ROD EXTENSIONS  
(SEE PAGE 96)

SH - HYDRAULIC OPTION (35 BAR 500 PSI)  
(SEE PAGE 97)

UB, UF, UR - URETHANE SHOCK PAD OPTION  
(SEE PAGE 97)



## Magnetic Front Mount Cylinder "MF"

MODEL	TYPE	STANDARD STROKES	"A"	PISTON AREA
LS	_,D	10mm - 100mm	43,0(1.69")	PUSH 45,6 cm <sup>2</sup> (7.07 in <sup>2</sup> )
LE	-	5mm - 100mm	53,0(2.09")	PULL 42,46 cm <sup>2</sup> (6.59 in <sup>2</sup> )
LH	_,D	5mm - 100mm	63,0(2.48")	PULL 42,46 cm <sup>2</sup> (6.59 in <sup>2</sup> )

	Standard Threads	"EM" Option
"B"	G1/8 PORT	1/8-27
"C"	M12X1,75	1/2-13
"D"	M10X1,5	3/8-24

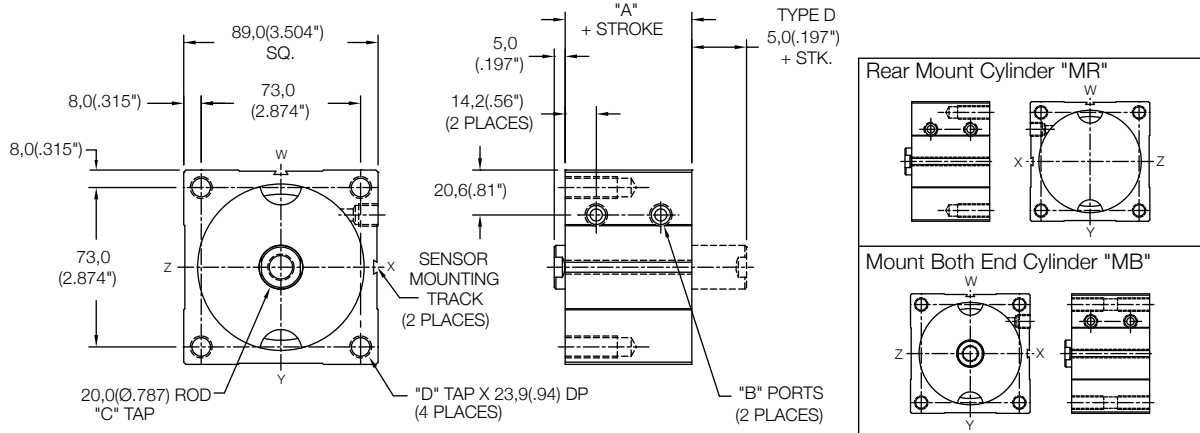

## Magnetic Thru Mount Cylinder "MT"

MODEL	TYPE	STANDARD STROKES	"A"	PISTON AREA
LS	_,D	10mm - 35mm	43,0(1.69")	PUSH 45,6 cm <sup>2</sup> (7.07 in <sup>2</sup> )
LE	-	5mm - 25mm	53,0(2.09")	PULL 42,46 cm <sup>2</sup> (6.59 in <sup>2</sup> )
LH	_,D	5mm - 15mm	63,0(2.48")	PULL 42,46 cm <sup>2</sup> (6.59 in <sup>2</sup> )

	Standard Threads	"EM" Option
"B"	G1/8 PORT	1/8-27
"C"	M12X1,75	1/2-13

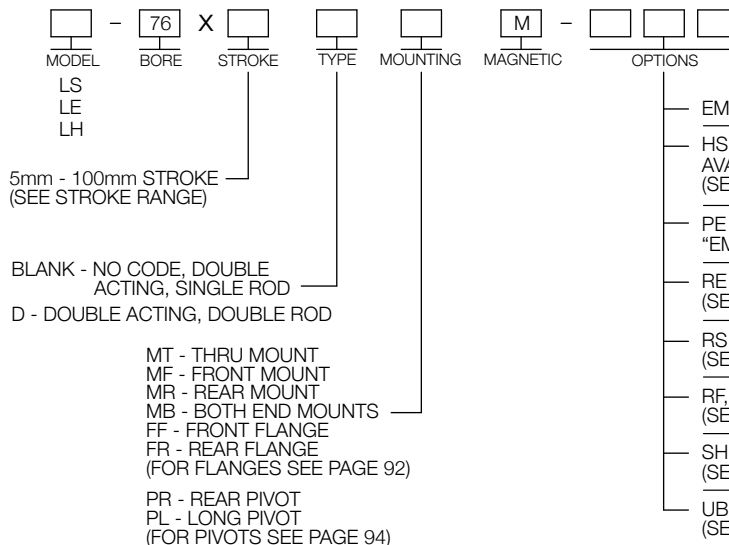
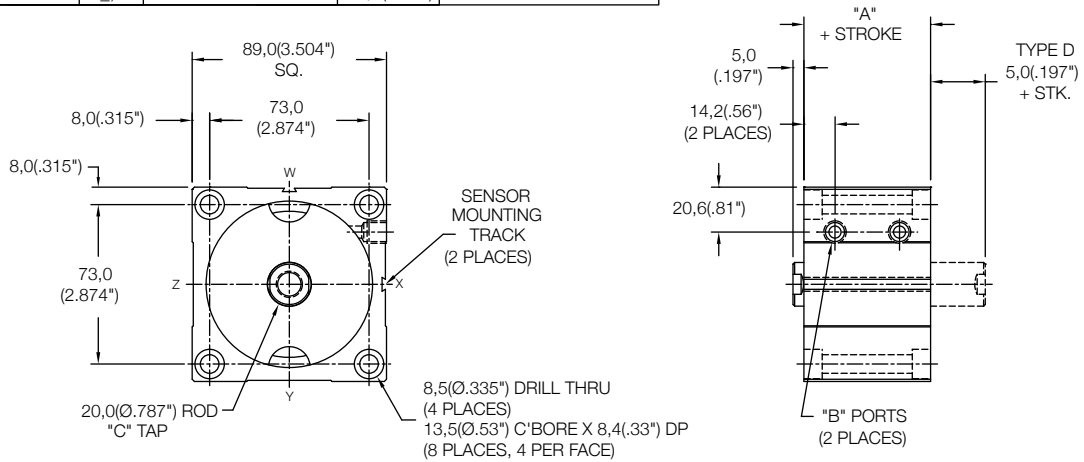

SENSORS SOLD SEPARATELY  
SKS, SKP, SCS, SCP - SOLID STATE  
LIMIT SENSORS (SEE PAGE 88)

## Magnetic Side Mount Cylinder "MS"

MODEL	TYPE	STANDARD STROKES	"A"	PISTON AREA
LS	...D	10mm - 15mm	43,0(1.69")	PUSH 45,6 cm <sup>2</sup> (7.07 in <sup>2</sup> )
LE	-	5mm	53,0(2.09")	PULL 42,46 cm <sup>2</sup> (6.59 in <sup>2</sup> )

	Standard Threads	"EM" Option
"B"	G1/8 PORT	1/8-27
"C"	M12X1,75	1/2-13
"D"	M10X1,5	3/8-24

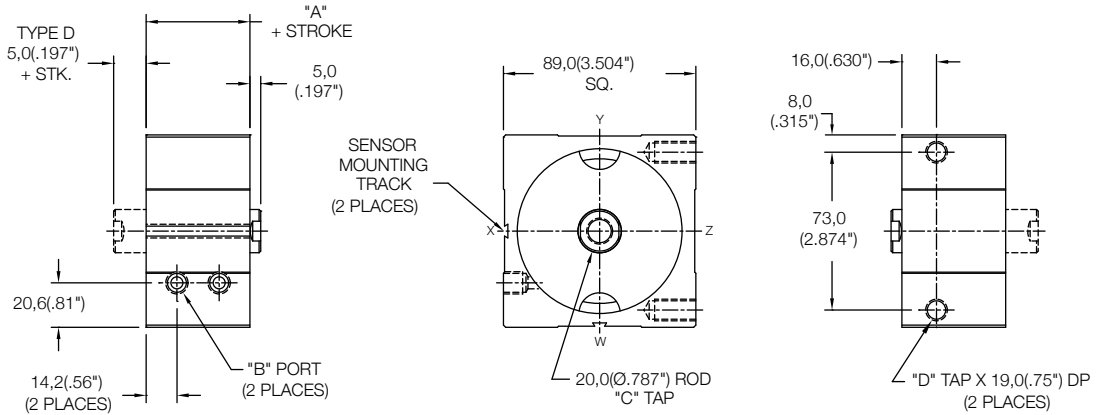

## Magnetic Side Mount Cylinder "MS"

MODEL	TYPE	STANDARD STROKES	"A"	PISTON AREA
LS	...D	20mm - 100mm	43,0(1.69")	PUSH 45,6 cm <sup>2</sup> (7.07 in <sup>2</sup> )
LE	-	10mm - 100mm	53,0(2.09")	PULL 42,46 cm <sup>2</sup> (6.59 in <sup>2</sup> )
LH	...D	5mm - 100mm	63,0(2.48")	PULL 42,46 cm <sup>2</sup> (6.59 in <sup>2</sup> )

	Standard Threads	"EM" Option
"B"	G1/8 PORT	1/8-27
"C"	M12X1,75	1/2-13
"D"	M10X1,5	3/8-24

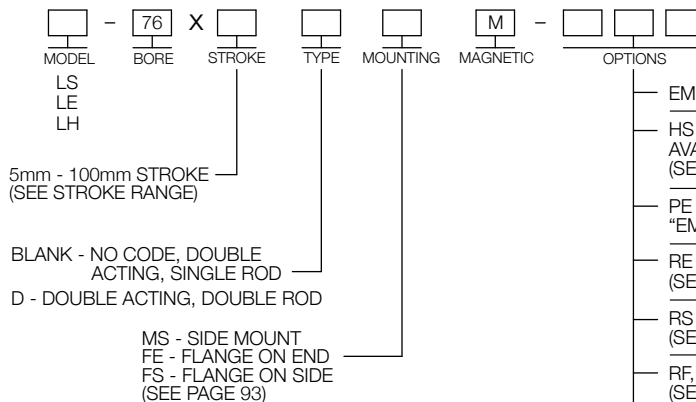
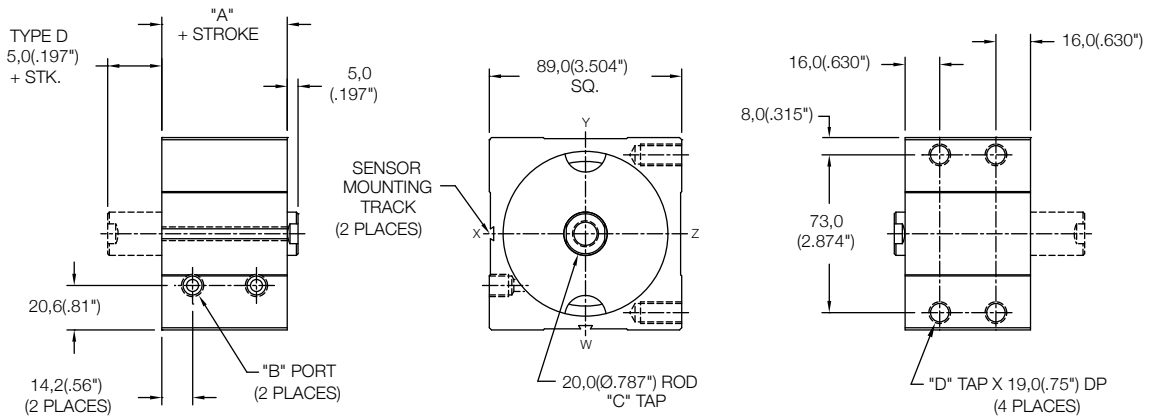

SENSORS SOLD SEPARATELY  
SKS, SKP, SCS, SCP - SOLID STATE  
LIMIT SENSORS (SEE PAGE 88)

### Non Magnetic Side Mount Cylinder "MS"

MODEL	TYPE	STANDARD STROKES	"A"	PISTON AREA
LS	_,D	10mm - 20mm	38,0(1.50")	PUSH 45,6 cm <sup>2</sup> (7.07 in <sup>2</sup> )
LE	-	5mm - 10mm	48,0(1.89")	PULL 42,46 cm <sup>2</sup> (6.59 in <sup>2</sup> )

	Standard Threads	"EM" Option
"B"	G1/8 PORT	1/8-27
"C"	M12X1,75	1/2-13
"D"	M10X1,5	3/8-24

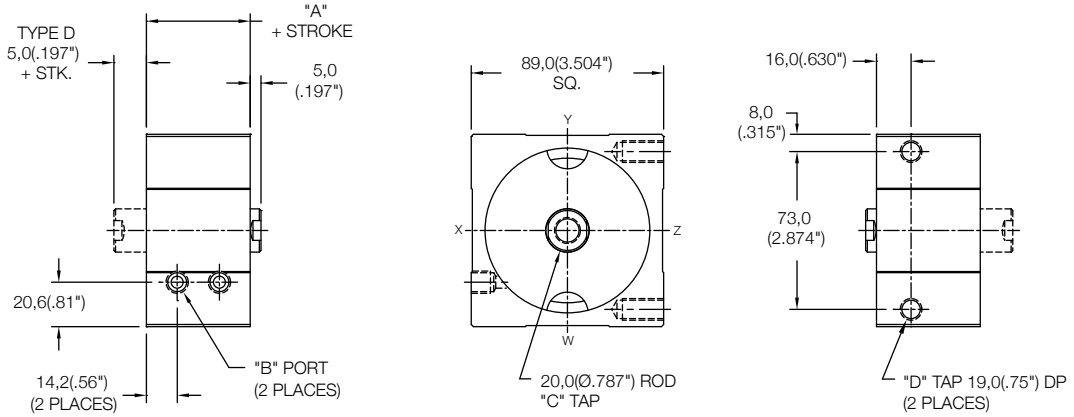

### Non Magnetic Side Mount Cylinder "MS"

MODEL	TYPE	STANDARD STROKES	"A"	PISTON AREA
LS	_,D	25mm - 100mm	38,0(1.50")	PUSH 45,6 cm <sup>2</sup> (7.07 in <sup>2</sup> )
LE	-	15mm - 100mm	48,0(1.89")	PULL 42,46 cm <sup>2</sup> (6.59 in <sup>2</sup> )
LH	_,D	5mm - 100mm	58,0(2.28")	PULL 42,46 cm <sup>2</sup> (6.59 in <sup>2</sup> )

	Standard Threads	"EM" Option
"B"	G1/8 PORT	1/8-27
"C"	M12X1,75	1/2-13
"D"	M10X1,5	3/8-24

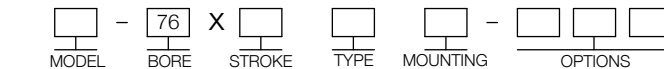
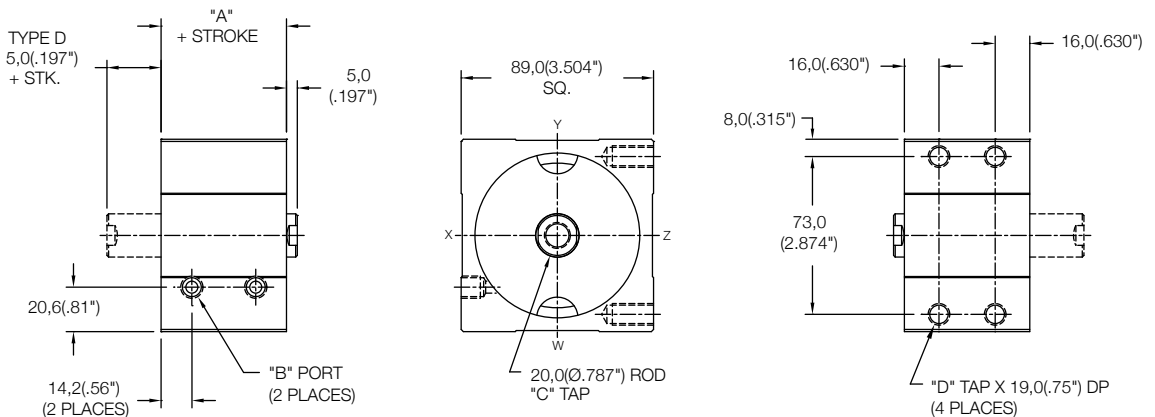

MODEL  
LS  
LE  
LH

5mm - 100mm STROKE  
(SEE STROKE RANGE)

BLANK - NO CODE, DOUBLE ACTING, SINGLE ROD  
D - DOUBLE ACTING, DOUBLE ROD

MS - SIDE MOUNT  
FE - FLANGE ON END  
FS - FLANGE ON SIDE  
(SEE PAGE 93)

EM - INCH THREADS & PORT OPTIONS

HS - HIGH TEMPERATURE SEALS OPTION:  
AVAILABLE ON LE AND LH MODELS ONLY  
(SEE PAGE 97)

PE - PORT ENLARGEMENT (AVAILABLE W/  
"EM" OPTION ONLY = 1/4-18 NPT PORTS)

RE - ROD EYE  
(SEE PAGE 96)

RS - MALE STUD FOR ROD END  
(SEE PAGE 96)

RF, RH, RN, RT, RV, RY - ROD EXTENSIONS  
(SEE PAGE 96)

SH - HYDRAULIC OPTION (35 BAR 500 PSI)  
(SEE PAGE 97)

UB, UF, UR - URETHANE SHOCK PAD OPTION  
(SEE PAGE 97)

## Non Magnetic Front Mount Cylinder "MF"

MODEL	TYPE	STANDARD STROKES	"A"	PISTON AREA
LS	...D	10mm - 100mm	41,5(1.63")	PUSH 81,07 cm <sup>2</sup> (12.57 in <sup>2</sup> )
LE	...	5mm - 100mm	51,5(2.03")	PULL 77,93 cm <sup>2</sup> (12.09 in <sup>2</sup> )
LH	...D	5mm - 100mm	61,5(2.42")	PULL 77,93 cm <sup>2</sup> (12.09 in <sup>2</sup> )

	Standard Threads	"EM" Option
"B"	G1/8 PORT	1/8-27
"C"	M12X1,75	1/2-13
"D"	M8X1,25	5/16-18

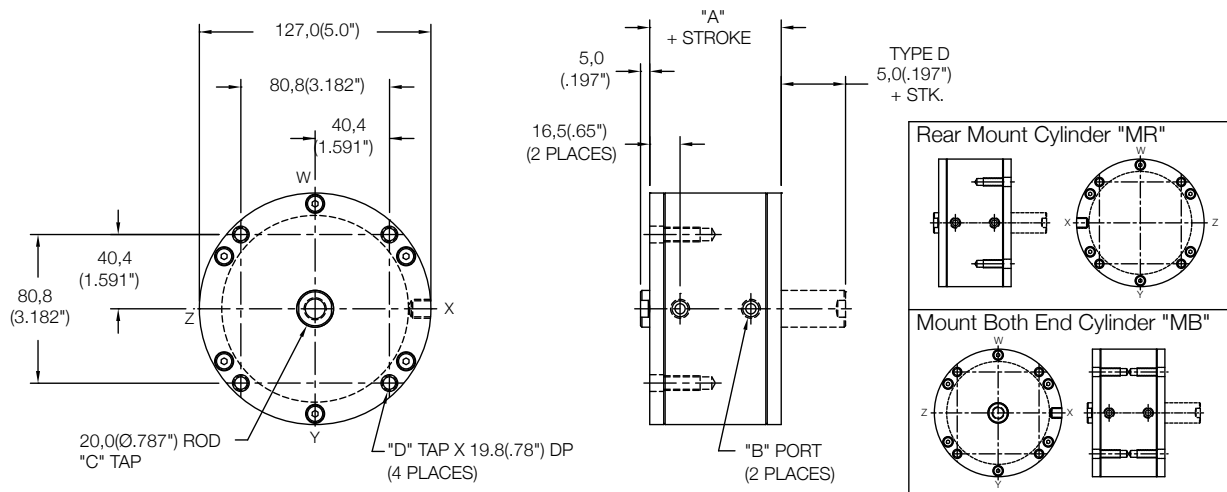

## Non Magnetic Thru Mount Cylinder "MT"

MODEL	TYPE	STANDARD STROKES	"A"	PISTON AREA
LS	...D	10mm - 50mm	41,5(1.63")	PUSH 81,07 cm <sup>2</sup> (12.57 in <sup>2</sup> )
LE	...	5mm - 40mm	51,5(2.03")	PULL 77,93 cm <sup>2</sup> (12.09 in <sup>2</sup> )
LH	...D	5mm - 30mm	61,5(2.42")	PULL 77,93 cm <sup>2</sup> (12.09 in <sup>2</sup> )

	Standard Threads	"EM" Option
"B"	G1/8 PORT	1/8-27
"C"	M12X1,75	1/2-13

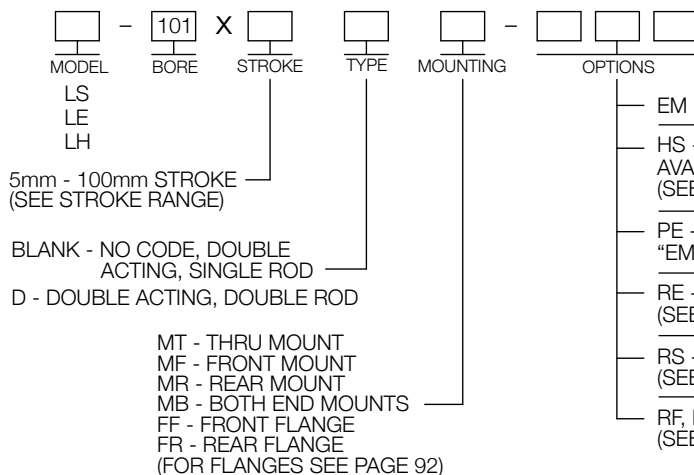
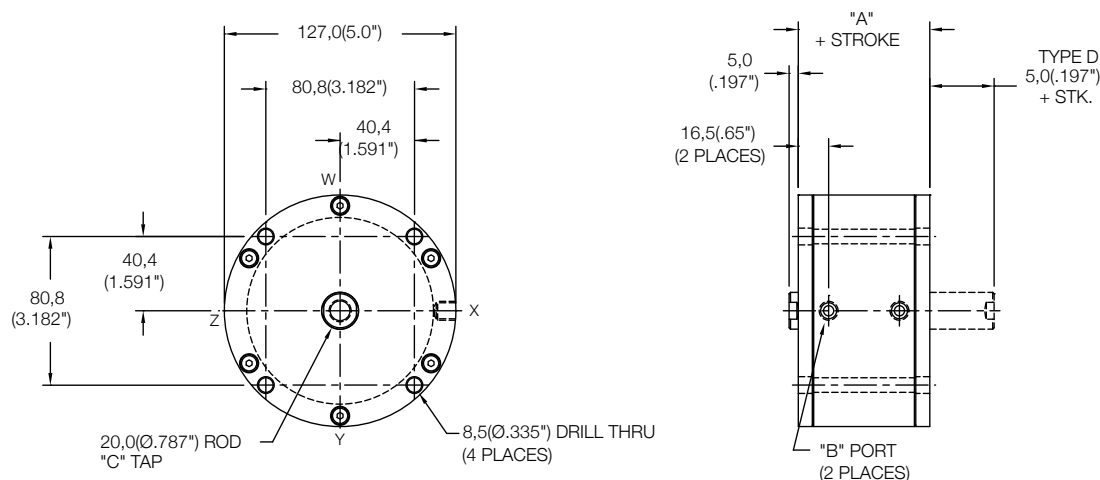

## Magnetic Front Mount Cylinder "MF"

MODEL	TYPE	STANDARD STROKES	"A"	PISTON AREA
LS	_,D	10mm - 100mm	51,5(2.03")	PUSH 81,07 cm <sup>2</sup> (12.57 in <sup>2</sup> )
LE	_	5mm - 100mm	61,5(2.42")	PULL 77,93 cm <sup>2</sup> (12.09 in <sup>2</sup> )
LH	_,D	5mm - 100mm	71,5(2.82")	PULL 77,93 cm <sup>2</sup> (12.09 in <sup>2</sup> )

	Standard Threads	"EM" Option
"B"	G1/8 PORT	1/8-27
"C"	M12X1,75	1/2-13
"D"	M8X1,25	5/16-18

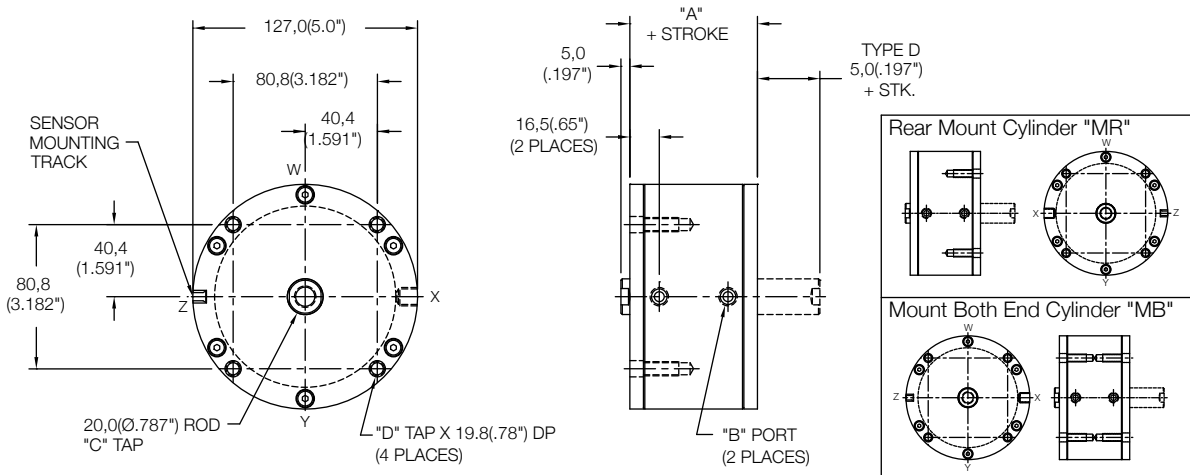

## Magnetic Thru Mount Cylinder "MT"

MODEL	TYPE	STANDARD STROKES	"A"	PISTON AREA
LS	_,D	10mm - 40mm	51,5(2.03")	PUSH 81,07 cm <sup>2</sup> (12.57 in <sup>2</sup> )
LE	_	5mm - 30mm	61,5(2.42")	PULL 77,93 cm <sup>2</sup> (12.09 in <sup>2</sup> )
LH	_,D	5mm - 20mm	71,5(2.82")	PULL 77,93 cm <sup>2</sup> (12.09 in <sup>2</sup> )

	Standard Threads	"EM" Option
"B"	G1/8 PORT	1/8-27
"C"	M12X1,75	1/2-13

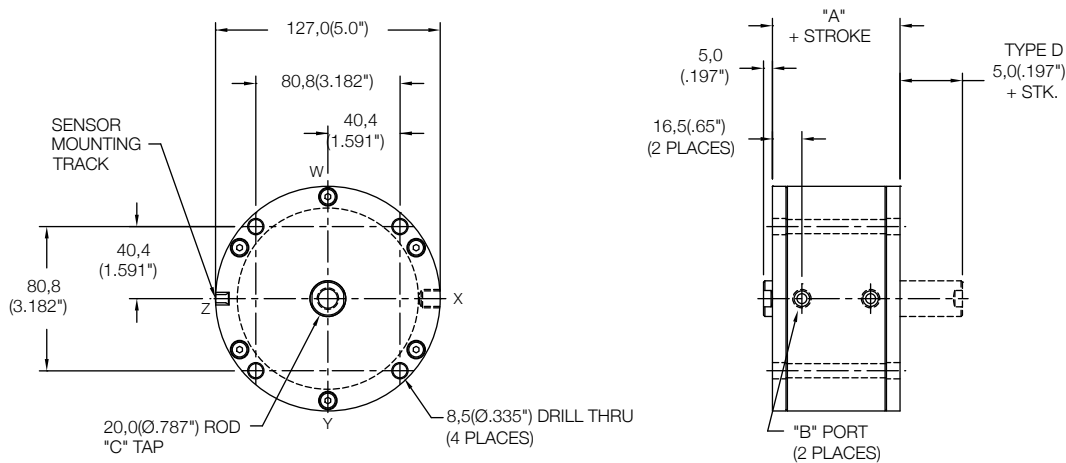

<table border="0"> <tr> <td>MODEL</td> <td>-</td> <td>101</td> <td>X</td> <td>STROKE</td> <td>TYPE</td> <td>MOUNTING</td> <td>MAGNETIC</td> <td>-</td> <td>OPTIONS</td> </tr> <tr> <td>LS LE LH</td> <td></td> <td></td> <td></td> <td></td> <td></td> <td></td> <td>M</td> <td></td> <td></td> </tr> </table> <p>5mm - 100mm STROKE (SEE STROKE RANGE)</p> <p>BLANK - NO CODE, DOUBLE ACTING, SINGLE ROD D - DOUBLE ACTING, DOUBLE ROD</p> <p>MT - THRU MOUNT MF - FRONT MOUNT MR - REAR MOUNT MB - BOTH END MOUNTS FF - FRONT FLANGE FR - REAR FLANGE (FOR FLANGES SEE PAGE 92)</p>	MODEL	-	101	X	STROKE	TYPE	MOUNTING	MAGNETIC	-	OPTIONS	LS LE LH							M			<p>SENSORS SOLD SEPARATELY SKS, SKP, SCS, SCP - SOLID STATE LIMIT SENSORS (SEE PAGE 88)</p> <p>EM - INCH THREADS &amp; PORT OPTIONS</p> <p>HS - HIGH TEMPERATURE SEALS OPTION: AVAILABLE ON LE AND LH MODELS ONLY (SEE PAGE 97)</p> <p>PE - PORT ENLARGEMENT (AVAILABLE W/ "EM" OPTION ONLY = 1/4-18 NPT PORTS)</p> <p>RE - ROD EYE (SEE PAGE 96)</p> <p>RS - MALE STUD FOR ROD END (SEE PAGE 96)</p> <p>RF, RH, RN, RT, RV, RY - ROD EXTENSIONS (SEE PAGE 96)</p>
MODEL	-	101	X	STROKE	TYPE	MOUNTING	MAGNETIC	-	OPTIONS												
LS LE LH							M														

## Non Magnetic Front Mount Cylinder "MF"

MODEL	TYPE	STANDARD STROKES	"A"	PISTON AREA
LS	__D	10mm - 100mm	44,5(1.75")	PUSH 126,7 cm <sup>2</sup> (19.6 in <sup>2</sup> )
LE	__	5mm - 100mm	54,5(2.15")	
LH	__D	5mm - 100mm	64,5(2.54")	PULL 123,5 cm <sup>2</sup> (19.1 in <sup>2</sup> )

	Standard Threads	"EM" Option
"B"	G1/8 PORT	1/8-27
"C"	M12X1,75	1/2-13
"D"	M8X1,25	5/16-18

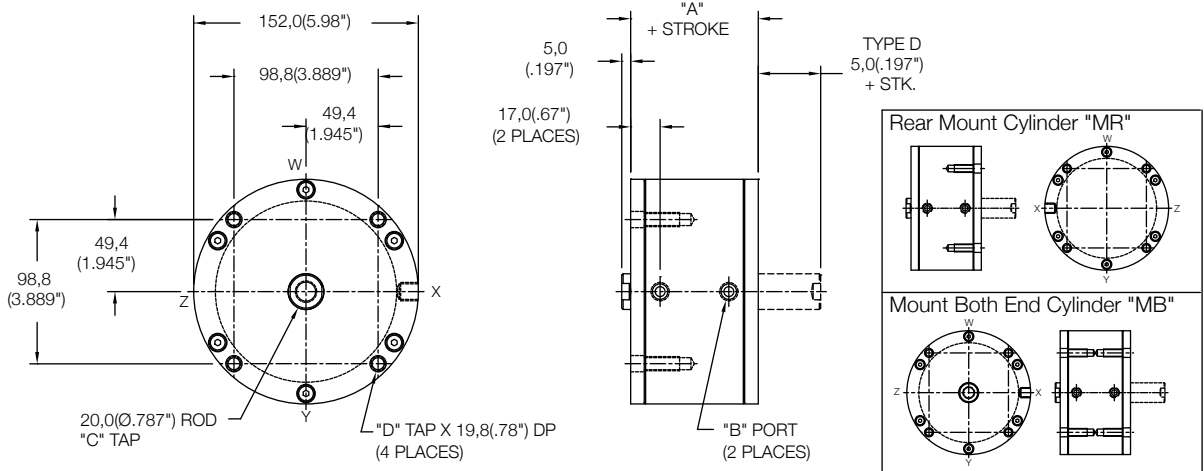

## Non Magnetic Thru Mount Cylinder "MT"

MODEL	TYPE	STANDARD STROKES	"A"	PISTON AREA
LS	__D	10mm - 45mm	44,5(1.75")	PUSH 126,7 cm <sup>2</sup> (19.6 in <sup>2</sup> )
LE	__	5mm - 35mm	54,5(2.15")	
LH	__D	5mm - 25mm	64,5(2.54")	PULL 123,5 cm <sup>2</sup> (19.1 in <sup>2</sup> )

	Standard Threads	"EM" Option
"B"	G1/8 PORT	1/8-27
"C"	M12X1,75	1/2-13

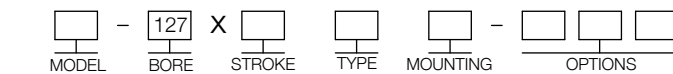
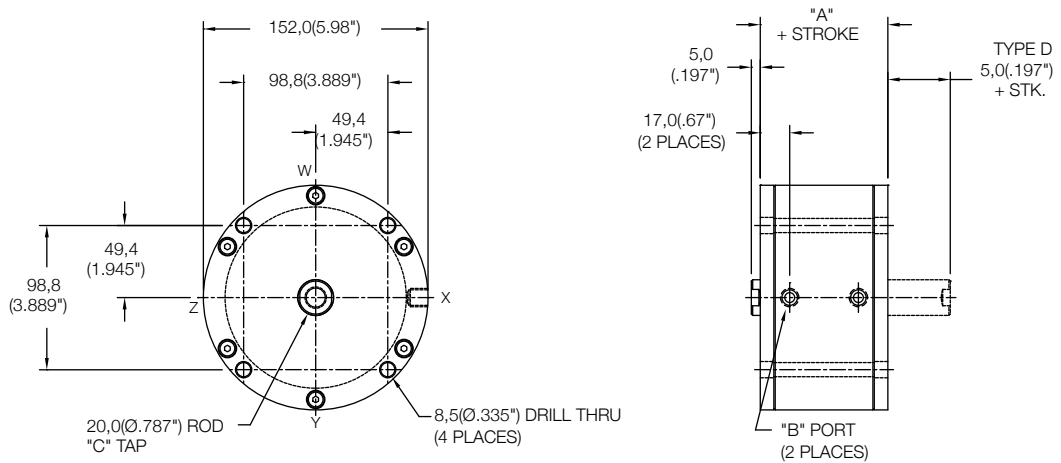

- MODEL: LS, LE, LH
- BORE: 127
- STROKE: 5mm - 100mm STROKE (SEE STROKE RANGE)
- TYPE: BLANK - NO CODE, DOUBLE ACTING, SINGLE ROD; D - DOUBLE ACTING, DOUBLE ROD
- MOUNTING: MT - THRU MOUNT; MF - FRONT MOUNT; MR - REAR MOUNT; MB - BOTH END MOUNTS; FF - FRONT FLANGE; FR - REAR FLANGE (FOR FLANGES SEE PAGE 92)
- OPTIONS:
  - EM - INCH THREADS & PORT OPTIONS
  - HS - HIGH TEMPERATURE SEALS OPTION: AVAILABLE ON LE AND LH MODELS ONLY (SEE PAGE 97)
  - PE - PORT ENLARGEMENT (AVAILABLE W/ "EM" OPTION ONLY = 1/4-18 NPT PORTS)
  - RE - ROD EYE (SEE PAGE 96)
  - RS - MALE STUD FOR ROD END (SEE PAGE 96)
  - RF, RH, RN, RT, RV, RY - ROD EXTENSIONS (SEE PAGE 96)



### Non Magnetic Front Mount Cylinder "MF"

MODEL	TYPE	STANDARD STROKES	"A"	PISTON AREA
LS	_,D	10mm - 100mm	51,0(2.00")	PUSH 181,46 cm <sup>2</sup> (28.2 in <sup>2</sup> ) PULL 176,55 cm <sup>2</sup> (27.45 in <sup>2</sup> )

	Standard Threads	"EM" Option
"B"	G1/8 PORT	1/8-27
"C"	M16X2,0	5/8-18
"D"	M8X1,25	5/16-18

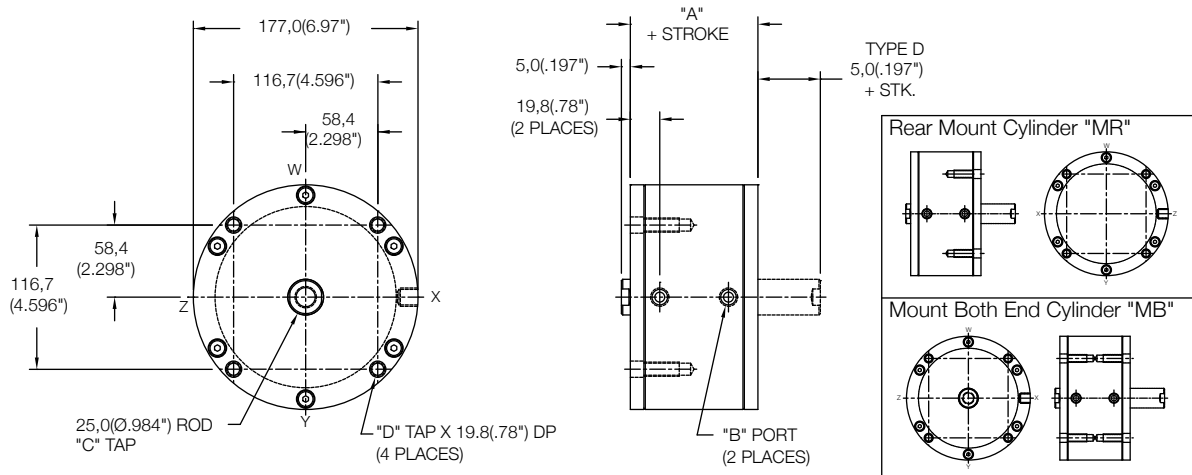

### Non Magnetic Thru Mount Cylinder "MT"

MODEL	TYPE	STANDARD STROKES	"A"	PISTON AREA
LS	_,D	10mm - 40mm	51,0(2.00")	PUSH 181,46 cm <sup>2</sup> (28.2 in <sup>2</sup> ) PULL 176,55 cm <sup>2</sup> (27.45 in <sup>2</sup> )

	Standard Threads	"EM" Option
"B"	G1/8 PORT	1/8-27
"C"	M16X2,0	5/8-18

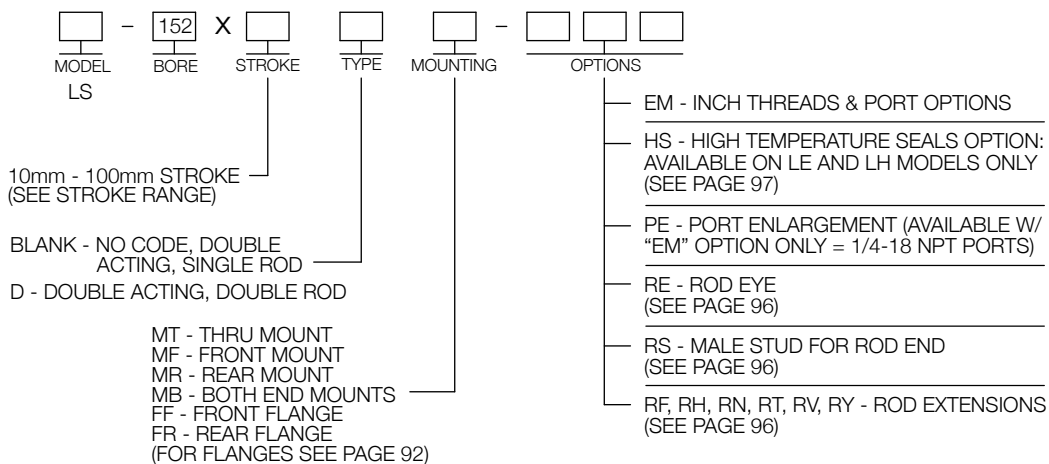
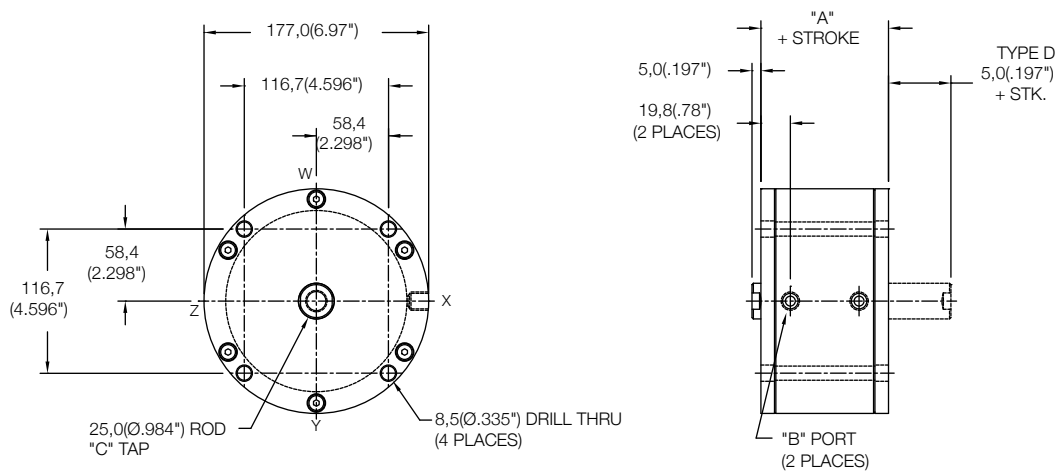



### Magnetic Front Mount Cylinder "MF"

MODEL	TYPE	STANDARD STROKES	"A"	PISTON AREA
LS	_,D	10mm - 100mm	61,0(2.40")	PUSH 181,46 cm <sup>2</sup> (28.2 in <sup>2</sup> ) PULL 176,55 cm <sup>2</sup> (27.45 in <sup>2</sup> )

	Standard Threads	"EM" Option
"B"	G1/8 PORT	1/8-27
"C"	M16X2,0	5/8-18
"D"	M8X1,25	5/16-18

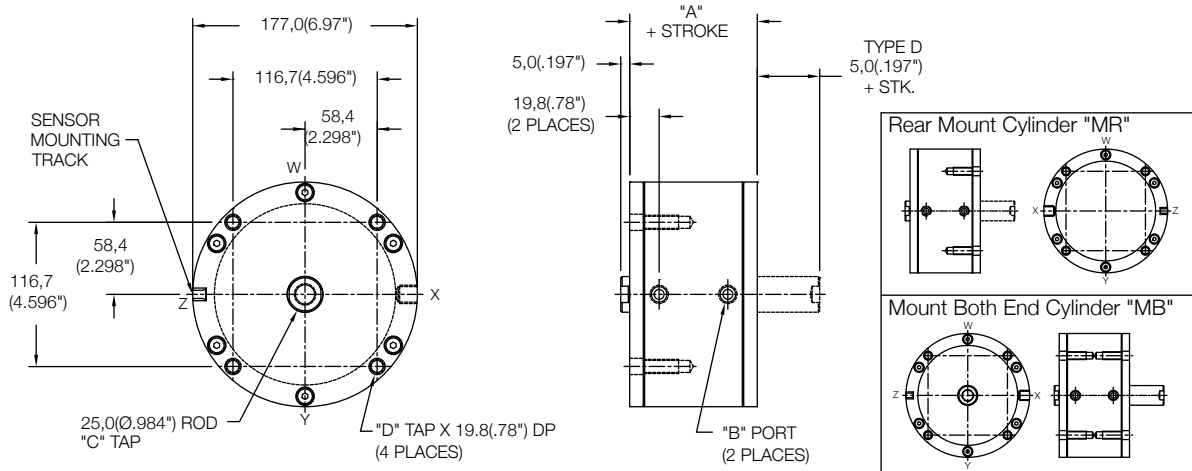

### Magnetic Thru Mount Cylinder "MT"

MODEL	TYPE	STANDARD STROKES	"A"	PISTON AREA
LS	_,D	10mm - 30mm	61,0(2.40")	PUSH 181,46 cm <sup>2</sup> (28.2 in <sup>2</sup> ) PULL 176,55 cm <sup>2</sup> (27.45 in <sup>2</sup> )

	Standard Threads	"EM" Option
"B"	G1/8 PORT	1/8-27
"C"	M16X2,0	5/8-18

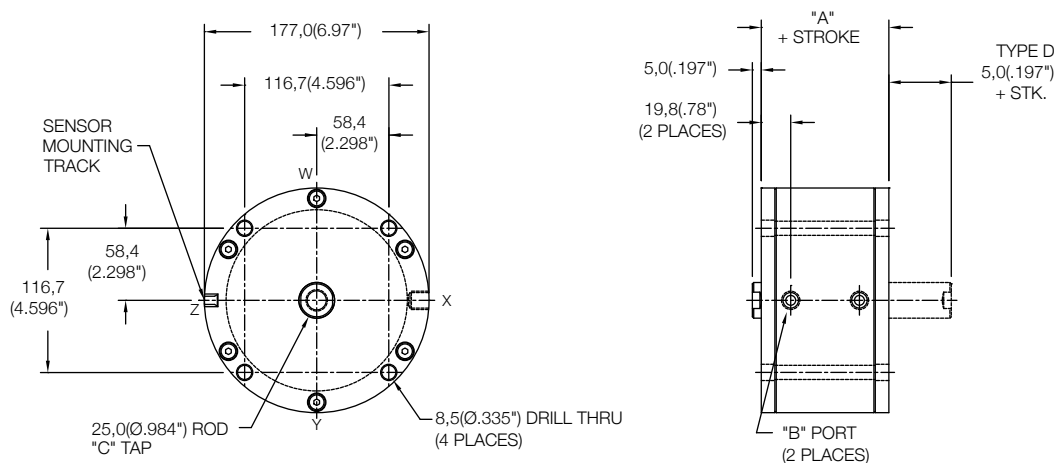

<table border="0"> <tr> <td>MODEL</td> <td>-</td> <td>152</td> <td>X</td> <td>STROKE</td> <td>TYPE</td> <td>MOUNTING</td> <td>MAGNETIC</td> <td>-</td> <td>OPTIONS</td> </tr> <tr> <td>LS</td> <td></td> <td></td> <td></td> <td></td> <td></td> <td></td> <td>M</td> <td></td> <td></td> </tr> </table>	MODEL	-	152	X	STROKE	TYPE	MOUNTING	MAGNETIC	-	OPTIONS	LS							M			<p>10mm - 100mm STROKE (SEE STROKE RANGE)</p> <p>BLANK - NO CODE, DOUBLE ACTING, SINGLE ROD</p> <p>D - DOUBLE ACTING, DOUBLE ROD</p> <p>MT - THRU MOUNT MF - FRONT MOUNT MR - REAR MOUNT MB - BOTH END MOUNTS FF - FRONT FLANGE FR - REAR FLANGE (FOR FLANGES SEE PAGE 92)</p>	<p>SENSORS SOLD SEPARATELY SKS, SKP, SCS, SCP - SOLID STATE LIMIT SENSORS (SEE PAGE 88)</p> <p>EM - INCH THREADS &amp; PORT OPTIONS</p> <p>HS - HIGH TEMPERATURE SEALS OPTION: AVAILABLE ON LE AND LH MODELS ONLY (SEE PAGE 97)</p> <p>PE - PORT ENLARGEMENT (AVAILABLE W/ "EM" OPTION ONLY = 1/4-18 NPT PORTS)</p> <p>RE - ROD EYE (SEE PAGE 96)</p> <p>RS - MALE STUD FOR ROD END (SEE PAGE 96)</p> <p>RF, RH, RN, RT, RV, RY - ROD EXTENSIONS (SEE PAGE 96)</p>
MODEL	-	152	X	STROKE	TYPE	MOUNTING	MAGNETIC	-	OPTIONS													
LS							M															