

AUTOMATIC 3 A BATTERY CHARGER FOR LEAD BATTERIES TYPE CBA-030

INSTRUCTION AND USER MANUAL



RAPID CHARGING WITH CURRENT CONTROL

INTERMEDIATE AND MAINTENANCE CHARGING,
WITH VOLTAGE CONTROL

SELF-PROTECTION AGAINST:

- SHORT CIRCUIT
- POLARITY INVERSION
- LOWERING (50%) OF THE BATTERY VOLTAGE

REMOTE REPETITION FOR INDICATOR LIGHTS

SUITABLE TO BE INSTALLED ALSO ON BOARD THE MACHINE

PARMA



ELCOS[®]

ITALY

OPERATION

Automatic charging in three phases:

- 3A rapid charge (current control), until 13,4 V (26,8 V) is reached in the battery.
- Intermediate charging via voltage control, until 13,5 V (27 V) is reached in the battery.
- Charge maintenance using a very low current value, but sufficient to maintain the voltage value at 13,5 V (27 V).

The **green indicator (LED)** is only lit when the following conditions happen at the same time:

- mains on;
- battery voltage above 65% (+/- 10%) of nominal value.

The **red indicator (LED)** is only lit when at least one of the following conditions happens:

- battery voltage above 65% (+/- 10%) of nominal value;
- polarity inversion;
- battery terminals short-circuit.

If there is overloading of the remote repetition terminals or if there is a mains failure, both of the indicators will remain unlit.

The **remote signals repetition** is available on terminals 11, 12 and 14:

The load connected between terminals 11 and 12 is supplied when the **green** indicator is lit;

The load connected between terminals 11 and 14 is supplied when the **red** indicator is lit;

TYPICAL LOAD CURVES

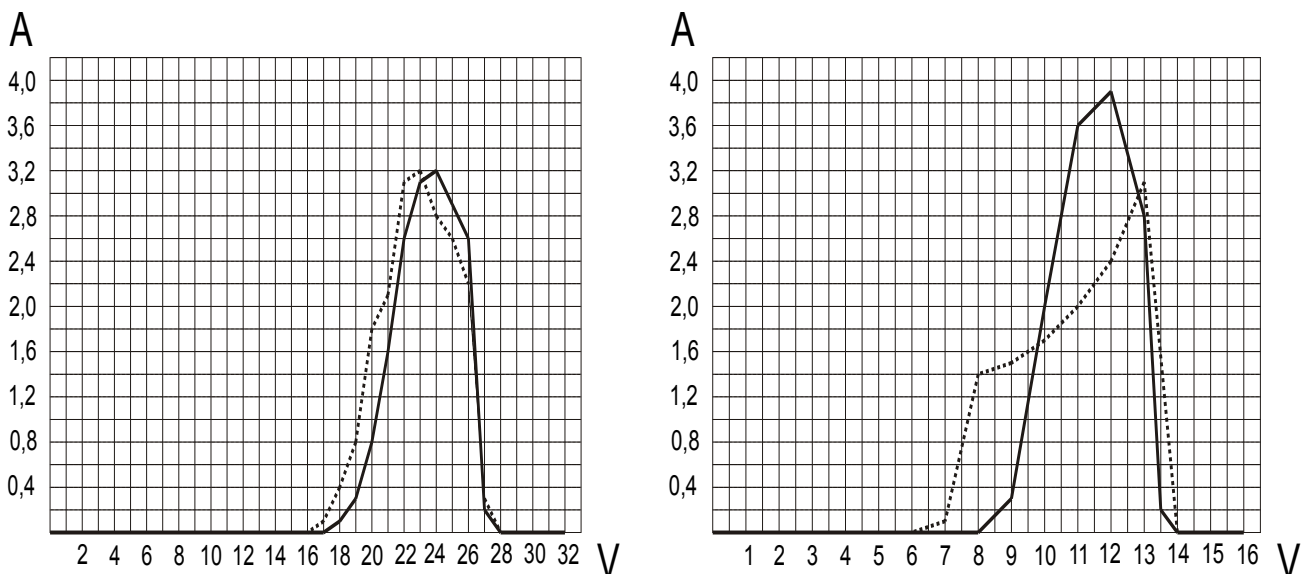

Measures in accordance with CEI-EN60335-2-29

Continuous line = initial characteristic

Broken line = work characteristic

CIRCUIT DIAGRAM

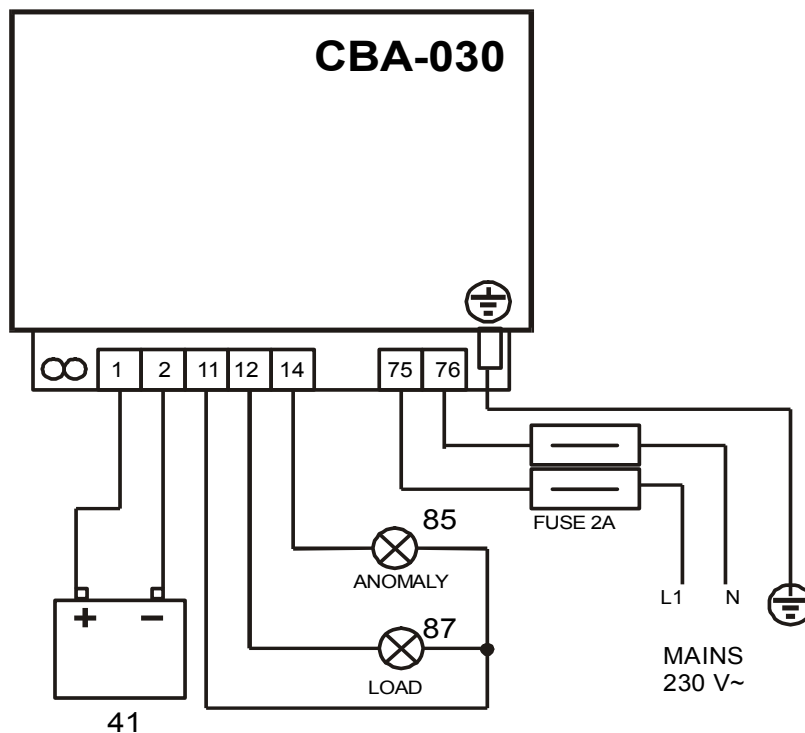

- (41) Battery
- (85) Anomaly indicator light
- (87) Load indicator light

INSTALLATION

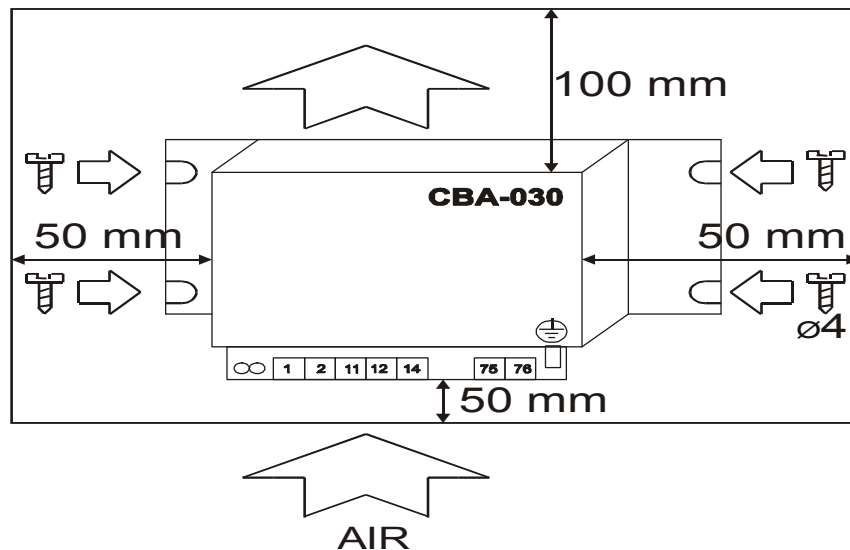

- Devices must be provided for disconnection from the mains: for example, switches with contacts opening greater than 3 mm or supply cables and plugs which are also accessible after installation.
- During the charging phase the equipment heats up. One must therefore ensure that the natural flow of air is not obstructed by nearby objects. Adhere closely to the indications concerning the minimum distances between the equipment and the surrounding parts.
- If the equipment is installed in a closed cabinet, holes or slits should be provided so that the heat can escape.
- Secure the equipment only at the points indicated, adhering to the minimum screws cross-sectional area.

DIMENSIONS

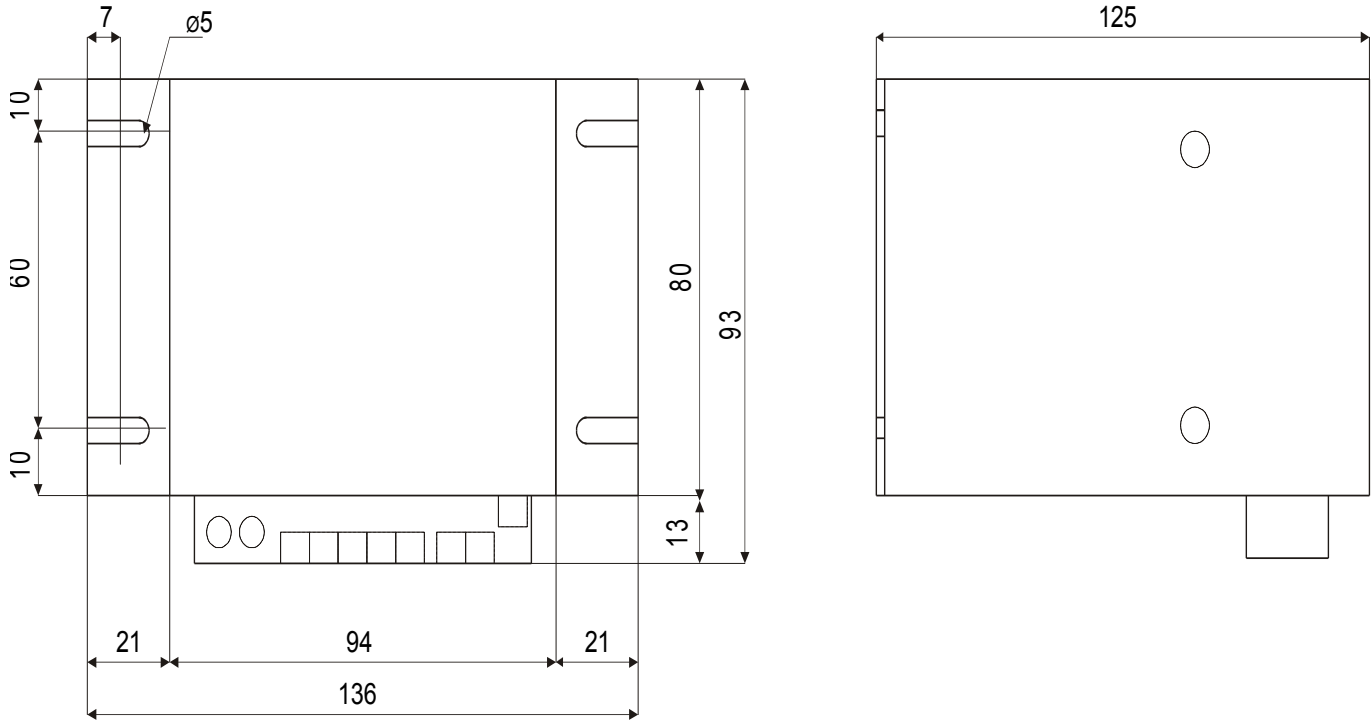

TECHNICAL DATA

Battery voltage:	12 V	24 V
Power supply:	230 V~ (207-253V~) 48-63 Hz	230 V~ (207-253 V~) 48-63 Hz
Nominal charge current:	3 A	3 A
Connectable battery:	6 cells lead/acid (min. capacity 30 Ah)	12 cells lead/acid (min. capacity 30 Ah)
Maximum absorbed power at 230V:	105 W	114 W
Full charging output	42 %	63 %
Circuit loading in absence of mains supply:	16 mA at 12V	16 mA at 24V
Max. ripple at the battery poles:	5 mV pp	5 mV pp
Max. load on outputs 11, 12 e 14:	3 W	3 W
Typical voltage on output 11:	16 V	30 V
Terminal board:	7 poles with screw	7 poles with screw
Degree of protection:	IP 00	IP 00
Temperature range:	-10 +50 °C	-10 +50 °C
Weight:	2200 g	2400 g

NOTICES

Used only to maintain the battery charge. Used in the starting circuits of diesel and petrol engines, such as those used in genset units, close-coupled pumps, compressor motors, etc. Constructed for installation only inside the electric panel.



Warning: Adhere closely to the following advice

- Install in such a way that there is always adequate heat disposal.
- Always install under other equipment which produces or spreads heat.
- Adhere to the instructions and distances indicated for installation.
- Check that the absorption and consumption of the connected equipment are compatible with the enclosed technical characteristics.
- Do not try to recharge non rechargeable batteries.
- When charging lead batteries, place the battery in a well-aired area.
- The connection to the mains must be made in accordance with the national installation rules.
- The equipment must be earthed via the relevant terminal.
- Connect the equipment to the battery without other conductor cutouts.
- Disconnect the equipment output terminals before any interventions on the battery.
- Handle and connect without mechanically stressing the electronic card.
- Make sure that no copper conductor cuttings or other waste material fall inside the equipment.

THIS BATTERY CHARGER IS NOT SUITABLE FOR OPERATING IN THE FOLLOWING CONDITIONS:

- Where the environmental temperature is outside the limits indicated in the enclosed technical sheet.
- Where the air pressure and temperature variations are so rapid as to produce exceptional condensation.
- Where there are high levels of pollution caused by dust, smoke, vapour, salts and corrosive or radioactive particles.
- Where there are high levels or heat from radiation caused by the sun, ovens or the like.
- Where attacks from mould or small animals are possible.
- Where there is the risk of fire or explosions.
- Where the battery charger can receive strong vibrations or knocks.
- Where the equipment is protected by barriers or casing with protection level less than IP20.

ELECTROMAGNETIC COMPATIBILITY

This battery charger functions correctly only if inserted in plants which conform with the CE marking standards; it meets the exemption requirements of the standard EN50082-2 but it cannot be excluded that malfunctions could occur in extreme cases due to particular situations.

The installer is responsible for checking whether the levels of disturbance are above those consented by the regulations.

CONDUCTION AND MAINTENANCE

The following maintenance operations should be performed every week:

- check that the indicators function;
- check the batteries;
- check that the conductors are tight, check the condition of the terminals.

UNLESS WE MAKE A WRITTEN DECLARATION STATING THE CONTRARY, THIS BATTERY CHARGER IS NOT SUITABLE FOR USE AS A CRITICAL COMPONENT IN EQUIPMENT OR PLANTS RESPONSIBLE FOR KEEPING PERSONS OR OTHER LIVING BEINGS ALIVE.

Any use which differs from that which is indicated in this instruction and user manual must be authorized by the manufacturer.

YOUR ELECTRICAL TECHNICIAN CAN ASK ANY QUESTIONS ABOUT
THIS BATTERY CHARGER BY TELEPHONING OUR TECHNICIAN

WARNING: COMPONENTS CARRYING DANGEROUS VOLTAGE LEVELS



Only assigned and suitably trained personnel are allowed to have battery charger access.

No maintenance operations are permitted unless the plant has been disconnected from the mains and from the battery.

The phases should be earthed and short-circuited as a safety measure.

Notwithstanding what is stated above, only assigned and trained personnel, when the plant is live, can perform the following operations:

- visual inspection of the battery charger, the connections and the markings;
- measurement of voltage and/or current values.

These operations must, in any case, be performed using a tool which guarantees the appropriate electrical protection.

ORDERING INFORMATION

Type CBA-030 230/12 V

Type CBA-030 230/24 V

Code 00010413

Code 00010414